

16572-B



STOP

DO NOT RETURN TO THE STORE!

If you discover missing or damaged parts, or if you have questions about the building process, please reach out to us directly for the fastest service.

24/7 Support

help.backyardproducts.com



- Answers to frequently asked questions
- Technical assistance and how-to videos
- Submit a help request
- Request replacement parts

Business Hours

(734) 242-6900

Monday - Friday 8:00am - 6:00pm EST
Saturday - Sunday Closed



Did you enjoy building your shed?

JOIN OUR TEAM

AND MAKE UP TO \$1,500/WEEK*

Call a Recruiter Today! 734-365-7000



Flexible schedule



No selling,
just building



Bonus incentives
available

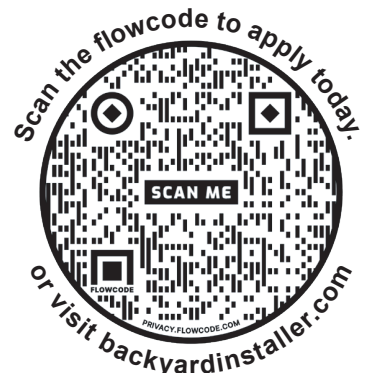

*based on number of completed installations

(This page intentionally left blank.)

STUDIO SHED 10' x 7'-6" (304,8 x 228,6 cm)

ACTUAL FLOOR SIZE IS 120" x 90" (304,8 x 228,6 cm)

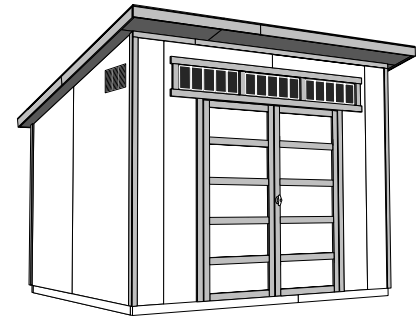
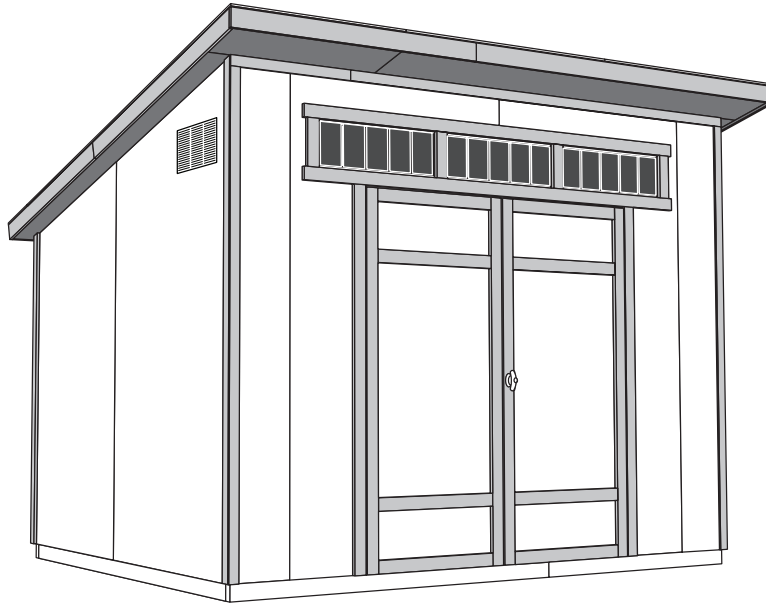
KEEP THIS MANUAL FOR FUTURE REFERENCE**Two options for door trim.****⚠ IMPORTANT! ⚠****READ INSTRUCTIONS THOROUGHLY PRIOR TO BEGINNING ASSEMBLY.****BEFORE YOU BEGIN****• BUILDING RESTRICTIONS AND APPROVALS**

Be sure to check local building department and homeowners association for specific restrictions and/ or requirements before building.

• ENGINEERED DRAWINGS

Contact our Customer Service Team if engineered drawings are needed to pull local permits.

• SURFACE PREPARATION

To ensure proper assembly you must build your shed on a level surface.

Recommended methods and materials to level your shed are listed on page 7.

• CHECK ALL PARTS

Inventory all parts listed on pages 4-6.

• ADDITIONAL MATERIALS

You will need additional materials to complete your shed. See page 3 for required and optional materials and quantities.

*****CONTACT OUR CUSTOMER SERVICE TEAM
IF ANY PARTS ARE MISSING OR DAMAGED*******- Order form and warranty at back of manual -****Call: 1-877-743-3400 email: customerservice@backyardproductsllc.com**

TOOLS

Required

Phillips Screwdriver 

Drill / Driver 
 1/4" Drill Bit
 3/8" Drill Bit
 1/2" Drill Bit
 #2 Phillips Drive Bit

Hammer 

Level 

Pencil 

Tape Measure 

Square  or 

Utility Knife 
 Shingle Blades 

Caulk Gun 

Paint Tools 

Safety Glasses 

Ladder 

Optional

Tool Belt/
Nail Pouch 

Tin Snips
(for drip edge) 

Chalk Line 

Nail Gun
• gun nails 

Gloves 

Safety! Always use approved safety glasses during assembly.

HELPFUL REMINDER SYMBOLS

Look for these symbols for helpful reminders throughout this manual.

 = Assistance Required; two or more people.

 = Ensure squareness.

 = Important required step or operation.

 = Helpful assembly hint.

 = Mark part with pencil.

 **BEGIN** = Beginning of steps for assembly or installation.

 **FINISH** = You have finished the assembly or installation.

 = Level

ORIENT LUMBER AND TRIM FOR BEST APPEARANCE

Framing lumber is graded for structural strength and not appearance. Exterior trim is graded for one good side.

Always install the material leaving the best edge and best surface visible. Please remember that these blemishes in no way negatively affect the strength or integrity of our product. (See Fig. A, B, C.)

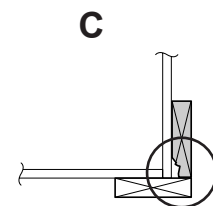
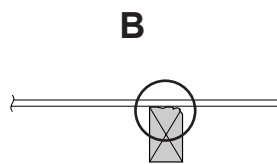
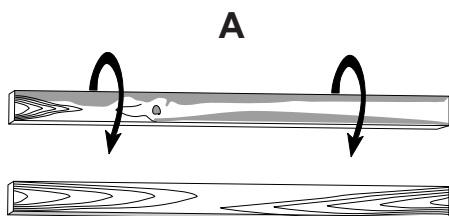

ADDITIONAL MATERIALS

FOUNDATION OR FLOOR MATERIALS

- This shed kit includes a complete wood floor system.
- This shed kit does not include ANY leveling materials.
- See the **FLOOR LEVELING** section on page 7 for recommended methods and suggested materials to properly level your floor, as this will vary depending on your specific site.

REINFORCED WOOD FLOOR FRAME (OPTIONAL)

IMPORTANT! The included floor has been designed for general use. Depending on your specific use you may want to construct a heavy duty floor frame by adding additional floor joists (shown below). Below is a list of additional materials (not included):

- x2** 2 x 4 x 87" (5 x 10 x 221 cm) Treated Lumber
- x8** ea. 3" (7,6 cm) Hot Dipped Galvanized Nails

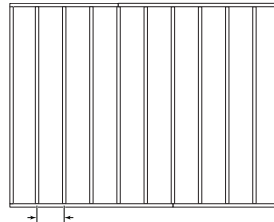

Optional 12" (30,1 cm) spacing.
• Standard spacing is 16" (40,7 cm).

FRAMING NAILS

Boxed Nails - Or - *Nail Gun* **Strip/Coil Nails**

x2 lbs.

x150

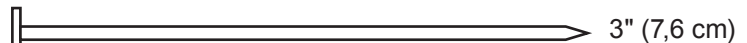

x3 lbs.

x625

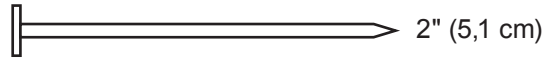

COMPLETING YOUR SHED

You will need these additional materials:

3-TAB SHINGLES 4 Bundles

1" GALVANIZED ROOFING NAILS.... 3 Lbs
For shingles.

PAINT FOR SIDING 2 Gallons
Use 100% acrylic latex exterior paint. (2) coats recommended.

PAINT FOR TRIM 1 Quart
Use 100% acrylic latex exterior paint.

CAULK 3 Tubes
Use acrylic latex exterior caulk that is paintable. 

1" GALVANIZED ROOFING NAILS..... 1/4 Lb
For roofing felt.



TO VALIDATE YOUR WARRANTY YOU MUST USE THE FOLLOWING:



DRIP EDGE 50 Feet

#15 ROOFING FELT
To cover 99 Sq. Ft. of roof area.

CAULK 1 Tube
For windows use acrylic latex exterior caulk that is paintable.

REFER TO THE BACK OF THIS MANUAL AND THE MANUFACTURER'S INSTRUCTIONS FOR INSTALLATION OF SHINGLES, DRIP EDGE AND FELT.

PARTS IDENTIFICATION AND SIZES

Part identification letters are stamped on some parts.

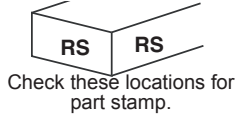

Treated lumber is stamped:

TREATED

WOOD SIZE CONVERSION CHART

Nominal Board Size	Actual Size
2 x 4.....	1-1/2" x 3-1/2" (3,8 x 8,9 cm)
1 x 4.....	3/4" x 3-1/2" (1,9 x 8,9 cm)
2 x 3.....	1-1/2" x 2-1/2" (3,8 x 6,3 cm)
1 x 3.....	3/4" x 2-1/2" (3,8 x 6,3 cm)

PARTS LIST



INVENTORY YOUR PARTS before you begin.

We suggest sorting parts by the category they are listed in.







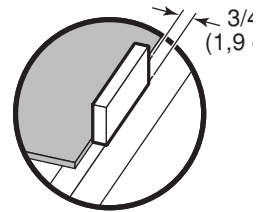







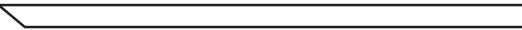

Category	Part ID	Dimensions	Notes
FLOOR	x2	TREATED	2 x 4 x 48" (5,1 x 10,2 x 121,9 cm)
	x2	TREATED	2 x 4 x 72" (5,1 x 10,2 x 182,8 cm)
	x9	TREATED	2 x 4 x 87" (5,1 x 10,2 x 220,9 cm)
WALLS	x4	RD	2 x 4 x 16 - 1/2" (5,1 x 10,2 x 41,9 cm)
	x2	RR	2 x 4 x 28" (5,1 x 10,2 x 71,1 cm)
	x2	BMA	2 x 4 x 45 - 5/8" (5,1 x 10,2 x 115,8 cm)
	x3	SP	2 x 4 x 48" (5,1 x 10,2 x 121,9 cm)
	x6	UX	2 x 4 x 64" (5,1 x 10,2 x 162,5 cm)
	x2	UM	2 x 4 x 68" (5,1 x 10,2 x 172,7 cm)
	x3	TM	2 x 4 x 72" (5,1 x 10,2 x 91,4 cm)
	x2	BFA	2 x 4 x 72-5/8" (5,1 x 10,2 x 184,5 cm)
	x2	BNA	2 x 4 x 74-1/4" (5,1 x 10,2 x 188,6 cm)
	x2	BJA	2 x 4 x 79-1/8" (5,1 x 10,2 x 201,3 cm)
	x2	BKA	2 x 4 x 85-1/2" (5,1 x 10,2 x 217,2 cm)
	x4	BLA	2 x 4 x 86" (5,1 x 10,2 x 218,4 cm)
	x1	UN	2 x 4 x 94-1/2" (5,1 x 10,2 x 240 cm)
	RAFTERS	x1	GAA
x9		BRA	2 x 3 x 10-1/2" (5,1 x 7,6 x 26,7 cm)
x2		BPA	1 x 3 x 33 - 1/8" (2,5 x 7,6 x 84,1 cm)
x2		HJ	1 x 3 x 72" (2,5 x 7,6 x 182,8 cm)
x9		BOA	2 x 4 x 93-3/16" (1,5 x 10,2 x 236,7 cm)
TRIM	x4	EY	19/32 x 2 - 1/2 x 9" (1,5 x 6,3 x 22,9 cm)
	x1	BYA	19/32 x 3-1/2 x 35-1/4" (1,5 x 8,8 x 89,5 cm)
	x2	BQA	2 x 3 x 33-1/8" (5,1 x 7,6 x 84,1 cm)
	x1	FS	2 x 3 x 35-1/4" (5,1 x 7,6 x 89,5 cm)
	x2	ZT	19/32 x 3-1/2 x 48" (1,5 x 8,8 x 121,9 cm)
	x1	BUA	19/32 x 3-1/2 x 52 - 3/8" (1,5 x 8,8 x 133 cm)
	x1	BXR	19/32 x 3 - 1/2 x 59 - 1/4" (1,5 x 8,8 x 150,4 cm)
	x1	BXL	19/32 x 3 - 1/2 x 59 - 1/4" (1,5 x 8,8 x 150,4 cm)

All treated lumber is stamped:

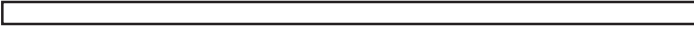
TREATED









PARTS LIST continued...

TRIM	<input type="checkbox"/> x2		2 x 3 x 72" (5,1 x 7,6 x 182,8 cm)	
	<input type="checkbox"/> x1		19/32 x 3-1/2 x 80" (1,5 x 8,8 x 203,2 cm)	
	<input type="checkbox"/> x2		19/32 x 2-1/2 x 91" (1,5 x 6,3 x 231,1 cm)	
	<input type="checkbox"/> x1		2 x 3 x 96" (5,1 x 7,6 x 243,8 cm)	
	<input type="checkbox"/> x1		19/32 x 3-1/2 x 96" (1,5 x 8,8 x 243,8 cm)	
CORNER/FREIZE TRIM	<input type="checkbox"/> x1		3/8 x 2 x 25-3/8" (0,9 x 5,1 x 64,4 cm)	
	<input type="checkbox"/> x2		3/8 x 2 x 68-3/4" (0,9 x 5,1 x 174,6 cm)	
	<input type="checkbox"/> x1		3/8 x 2 x 69-1/4" (0,9 x 5,1 x 175,8 cm)	
	<input type="checkbox"/> x1		3/8 x 2 x 69-1/4" (0,9 x 5,1 x 175,8 cm)	
	<input type="checkbox"/> x2		3/8 x 2 x 91-1/4" (0,9 x 5,1 x 231,7 cm)	
	<input type="checkbox"/> x1		3/8 x 2 x 93-1/4" (0,9 x 5,1 x 236,8 cm)	
	<input type="checkbox"/> x1		3/8 x 2 x 93-1/4" (0,9 x 5,1 x 236,8 cm)	
	<input type="checkbox"/> x1		3/8 x 2 x 96" (0,9 x 5,1 x 243,8 cm)	
SOFFIT	<input type="checkbox"/> x1		35-3/4 x 10-3/8 x 3/8" (90,8 x 26,3 x 1 cm)	
	<input type="checkbox"/> x1		95-3/8 x 10-3/8 x 3/8" (242,2 x 26,3 x 1 cm)	
	<input type="checkbox"/> x2		95-1/2 x 5-1/4 x 3/8" (242,5 x 13,3 x 1 cm)	
DOOR	<input type="checkbox"/> x8		19/32 x 2-1/2 x 26-5/8" (1,5 x 6,3 x 67,6 cm)	<input type="checkbox"/> x1 
	<input type="checkbox"/> x2		69" Door Stiffener (175,2 cm)	19/32" x 3-1/2" x 11-3/8" (1,5 x 8,9 x 28,9 cm)

PANEL PARTS LIST

Roof panels are 7/16" (1,1 cm) thick.

Floor panels are 5/8" (1,6 cm) thick.

ROOF PANELS	<input type="checkbox"/> x1		7/16 x 11-7/8 x 35-7/8" (1,1 x 30,2 x 91,1 cm)	
	<input type="checkbox"/> x1		7/16 x 11-7/8 x 96" (1,1 x 30,2 x 243,8 cm)	
	<input type="checkbox"/> x1		7/16 x 35-7/8 x 96" (1,1 x 91,1 x 243,8 cm)	
	<input type="checkbox"/> x2		7/16 x 48 x 96" (1,1 x 121,9 x 243,8 cm)	
FLOOR	<input type="checkbox"/> x1		5/8 x 23-7/8 x 90" (1,5 x 60,6 x 228,6 cm)	
	<input type="checkbox"/> x1		5/8 x 42 x 96" (1,5 x 106,6 x 243,8 cm)	
	<input type="checkbox"/> x1		5/8 x 48 x 96" (1,5 x 121,9 x 243,8 cm)	

NOTE: Panel parts are not stamped.

WALL PANEL & DOORS PARTS LIST

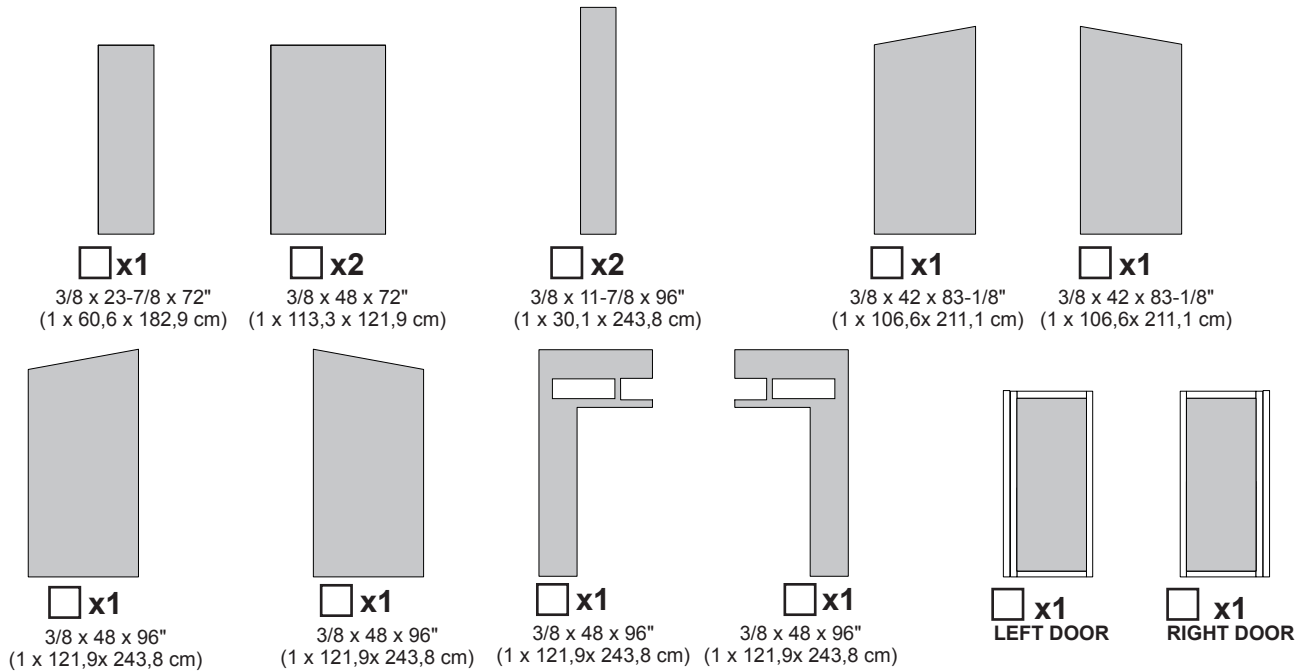

FASTENER/HARDWARE BAG

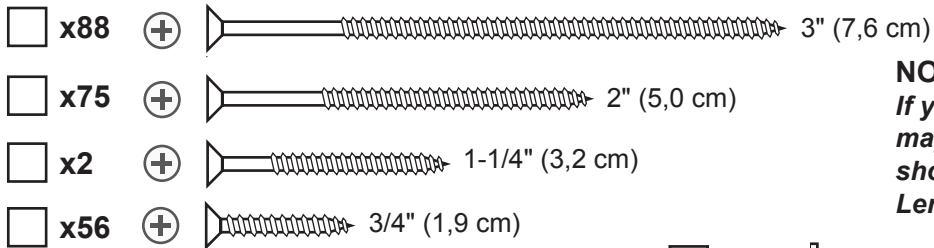

NOTE:

If you are using a nail gun, nails may be used where screws are shown for quicker assembly. Length of nail must match screw length.

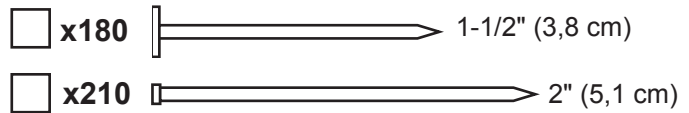

VENT, DOOR HARDWARE, AND WINDOW

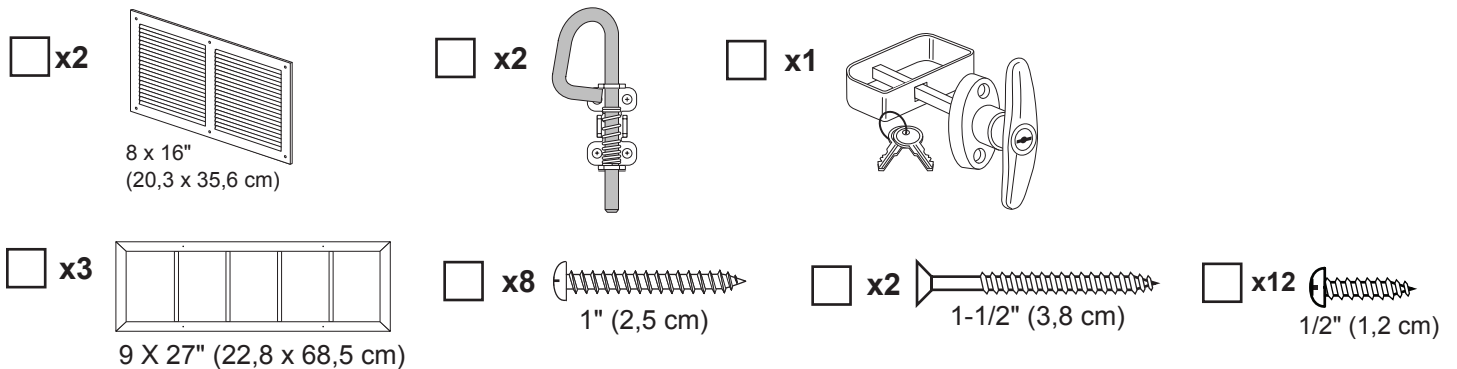

FLOOR LEVELING OPTIONS

There are multiple ways to level your floor frame. Our recommended leveling method is shown below. Leveling materials are not included in this kit.

PREFERRED METHOD - 4x4 TREATED RUNNERS

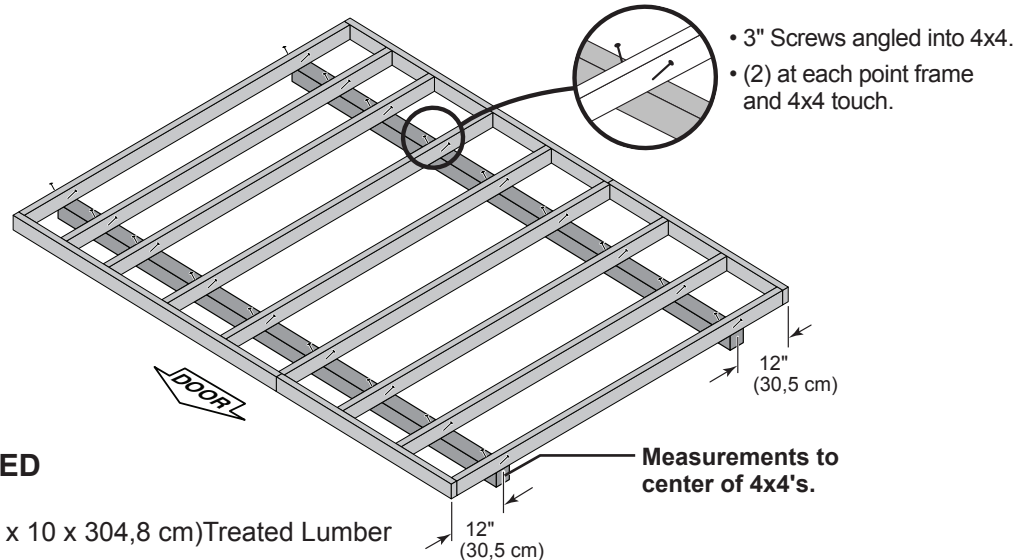

MATERIAL REQUIRED

x2 4 x 4 x 10' (10 x 10 x 304,8 cm) Treated Lumber

Fasteners for Frame to 4 x 4.
(3" Screws shown as one option.) Minimum (40) 3" screws / exterior grade.

Use only wood treated for ground contact and fasteners approved for use with treated wood.

Always support frame seams.

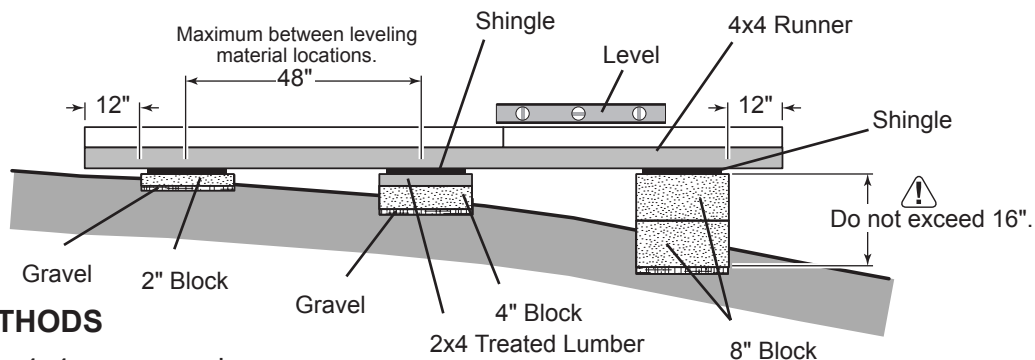

LEVELING METHODS

- Level under 4x4 runners only.
- Locate leveling material 12" from ends of runners and no more than 48" apart.
- Asphalt shingles should be used between 4x4 runners and blocks or treated lumber. Never use shingles in direct contact with ground.
- For best results and aiding in water drainage use gravel under each concrete block.

LEVELING MATERIALS

- Gravel
- Solid Masonry Blocks in 1", 2", 4" or 8" thickness
- 2x4 Treated Lumber
- Asphalt Shingles

Leveling higher than 16" not recommended.

CONCRETE

- If you are building your shed on a concrete foundation see the following page.

STOP!



LEVEL AND SQUARE FLOOR FRAME



STOP!

Before attaching floor decking, it is important to level and square the floor frame. A level and square floor frame is required to correctly construct your shed.

✓ **BEGIN**

- 1 See page 7 for the preferred floor leveling method.
- 2 Use level and check the frame is level before applying floor panels.
- 3 Check for frame squareness by measuring diagonally across corners. If the measurements are the same, the frame is square. The diagonal measurement will be approximately 150" (381 cm).
- 4 When the frame is level and square, secure one side of frame to the 4x4 runners using one fastener at ends of each runner. Move to the opposite end of the frame. Secure the frame to 4x4 runners with one fastener at ends of each runner. Ensure the frame remains square (**Fig. A**).

First, secure at ends with one fastener.

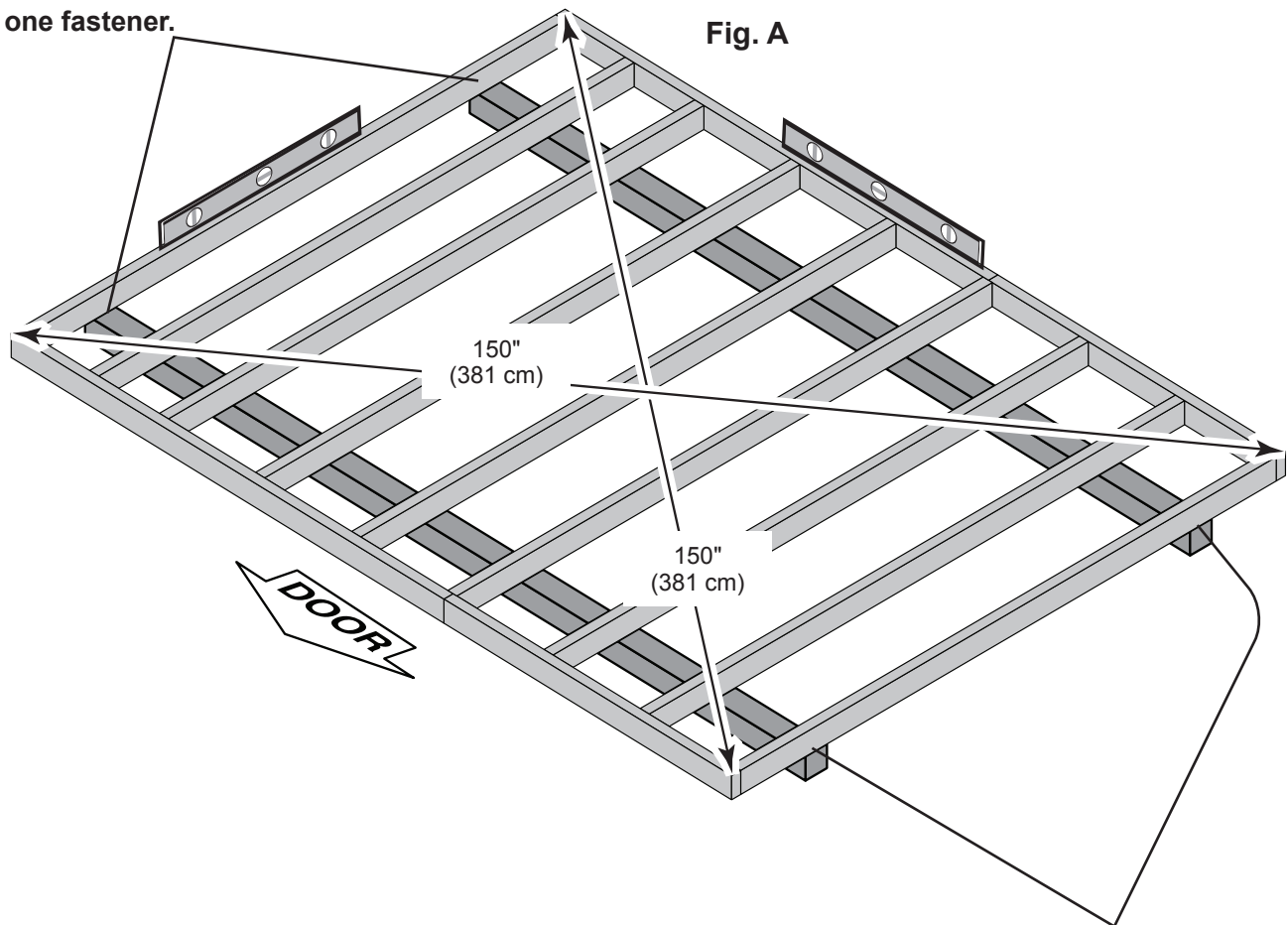

Second, secure at ends with one fastener.





After the floor frame is level and square, fasten the frame to the 4x4 runners at each connection to the 4x4 runners.

FLOOR PANELS

PARTS REQUIRED:

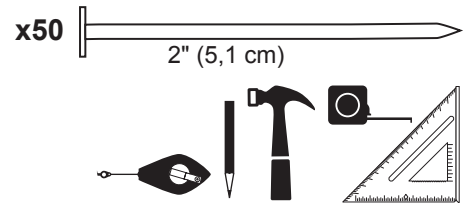
x1  5/8 x 48 x 96"
(1,6 x 121,9 x 243,8 cm)



BEGIN  **Ensure your floor frame is square by installing one panel and squaring frame.**

- 1** Install the 48" x 96" panel with the rough side up (painted-grid lines side) with the 48" edge and corner flush to the floor frame (**Fig A**). Secure panel with (2) 2" nails in the corners.
- 2** Move to the opposite side. Using the long edge of the panel as a lever, move the panel side-to-side until the top corner is flush to the floor frame (**Fig. B**). Secure panel with (2) 2" nails in the corners.
- 3** Check the floor frame is square by measuring diagonally across the frame corners. If the measurements are the same your floor frame is square. The measurement will be approximately 150" (381 cm) (**Fig. C**).
- 4** Continue securing the panel with 2" nails spaced 6" apart on edges and 12" apart inside panel. Use a chalk line or use pre-painted grid lines to nail into joists under panel.

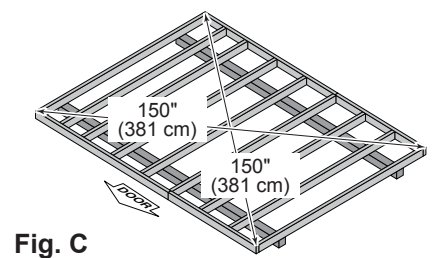
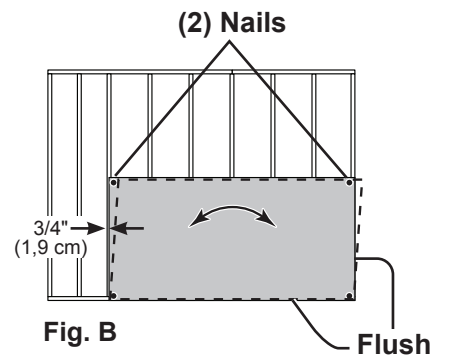
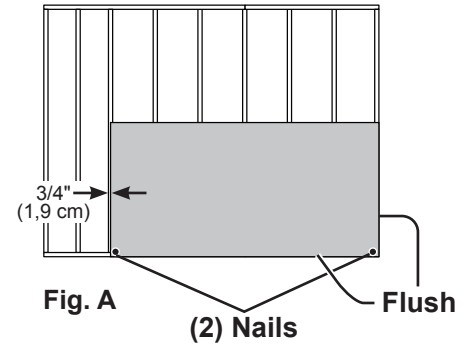
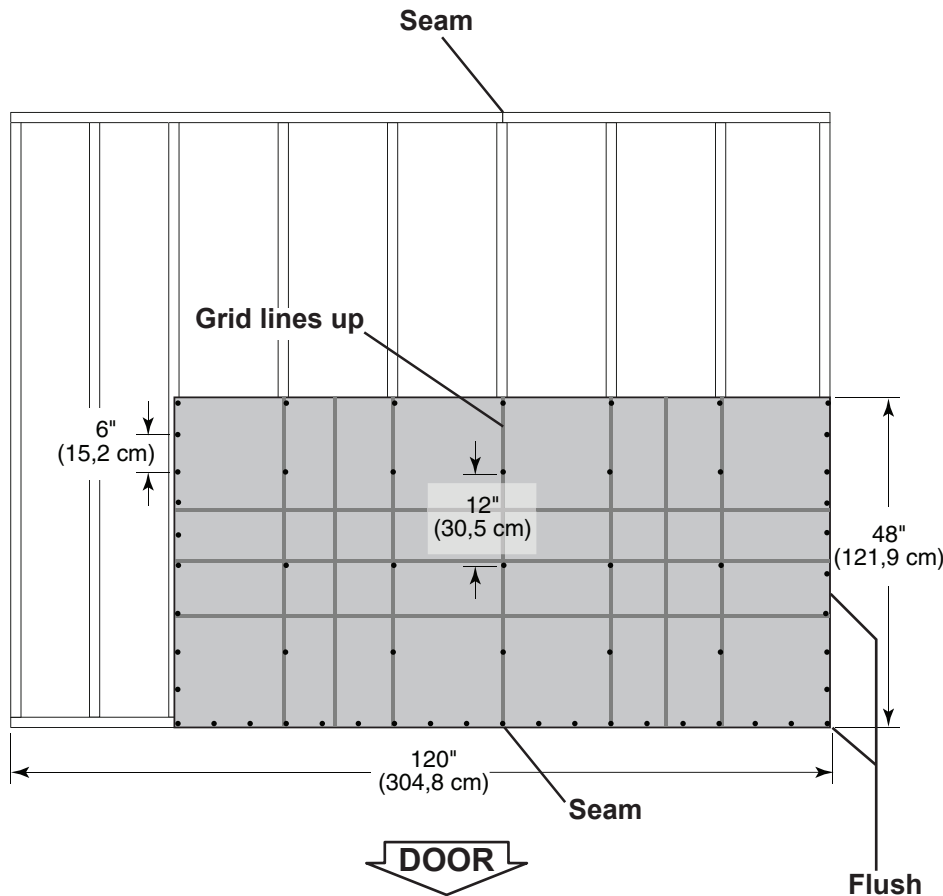
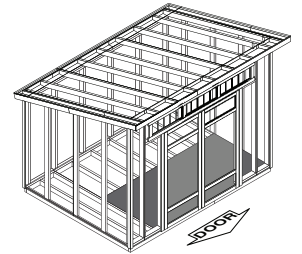

FLOOR PANELS

PARTS REQUIRED:

- x1**

5/8 x 42 x 96"
(1,6 x 106,7 x 243,8 cm)
- x1**

5/8 x 23-7/8 x 90"
(1,6 x 60,6 x 228,6 cm)

x91 2" (5,1 cm)



- 5** Continue installing panels with rough side up (painted grid lines). Use grid lines on panel during installation. Secure with 2" nails spaced 6" apart on edges, and 12" apart inside panels.

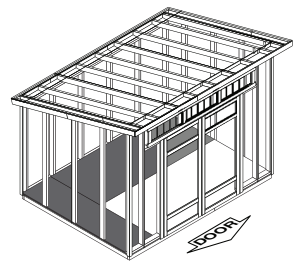

Your floor panels are now installed.

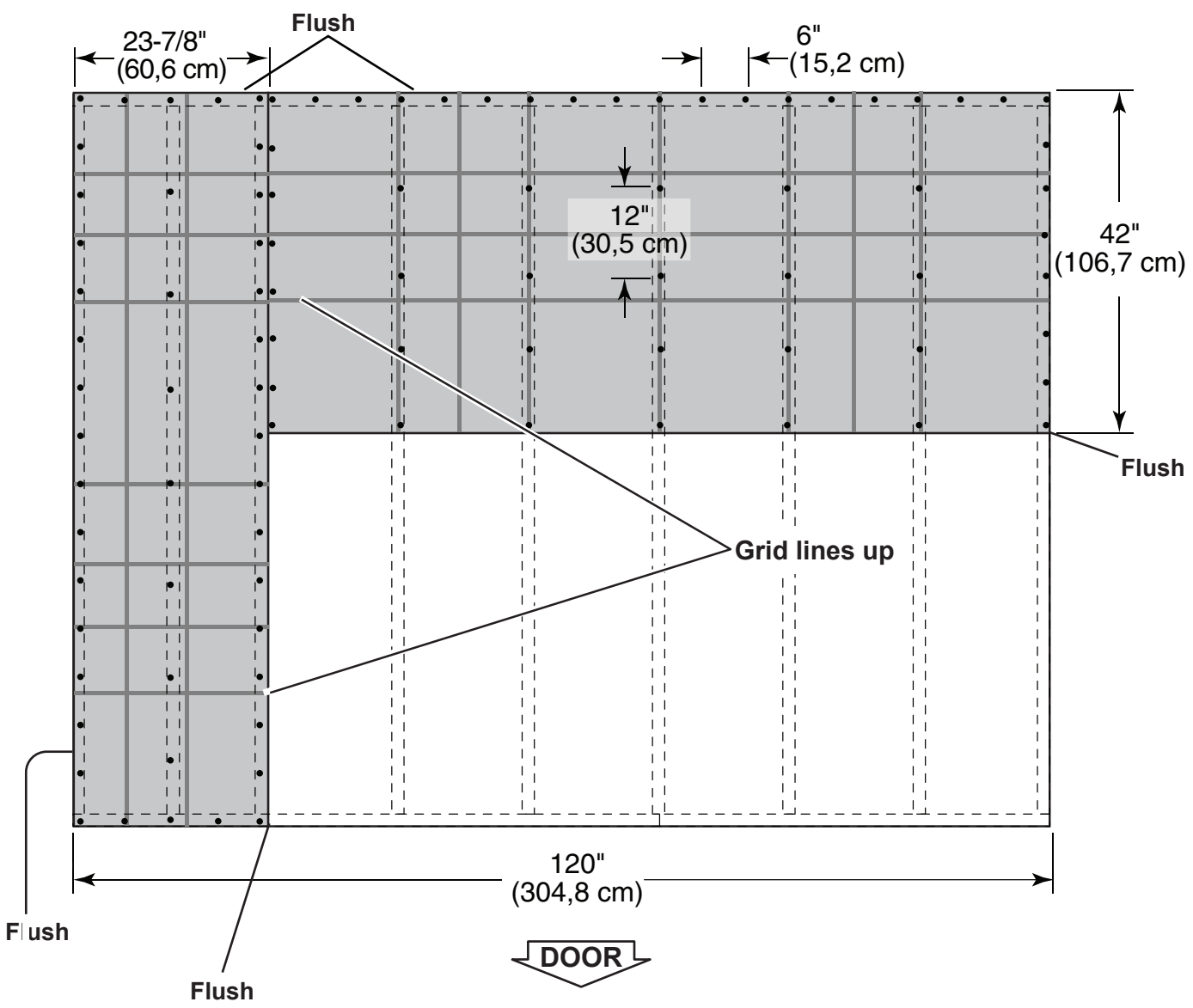

IMPORTANT!

STOP!

Check the floor frame is level after installing floor panels.
Re-level if needed.

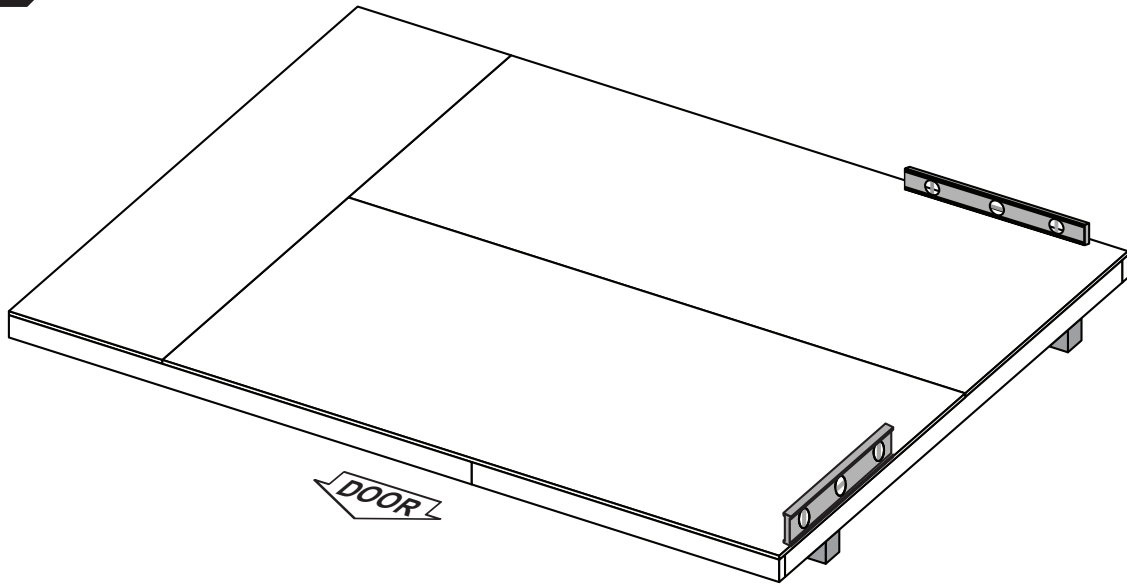

HINT:

- The floor should be used as a stable work surface for wall construction.
- Organize your assembly procedure during the build process to avoid over-handling of the walls.

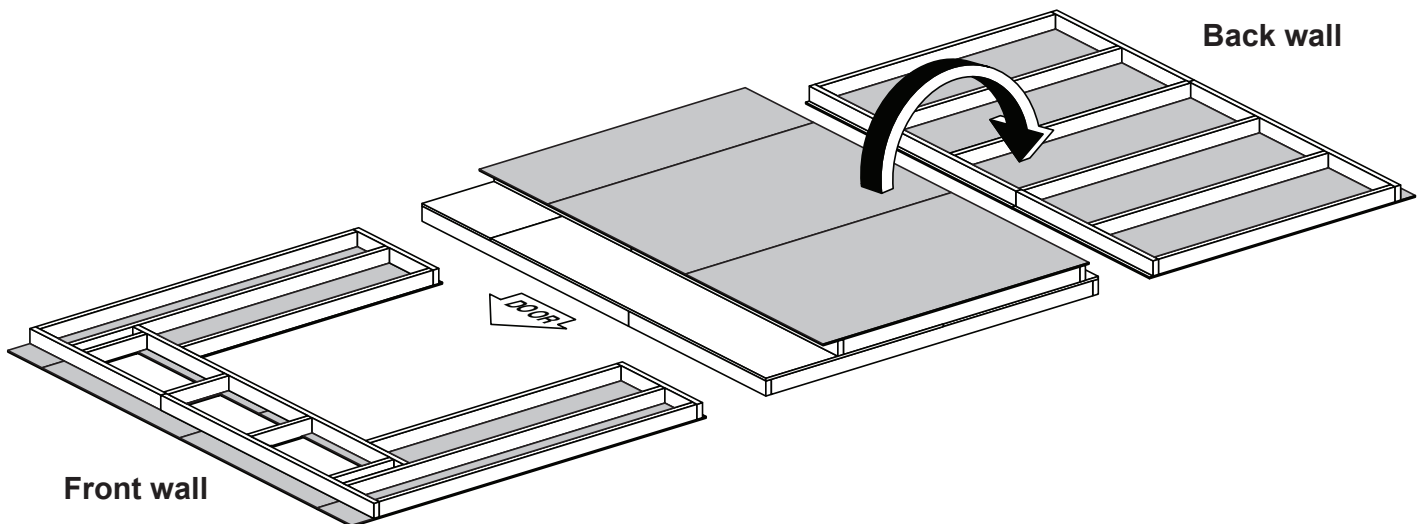

BACK WALL FRAME

PARTS REQUIRED:

x2 **SP** 2 x 4 x 48" (5,1 x 10,2 x 121,9 cm)

x6 **UX** 2 x 4 x 64" (5,1 x 10,2 x 162,5 cm)

x2 **TM** 2 x 4 x 72" (5,1 x 10,2 x 182,9 cm)

x28 3" (7,6 cm)

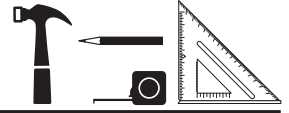

✓ BEGIN

- 1 Arrange parts on edge on floor. Measure and mark.
Secure with 3" nails at each mark and (4) 3" nails at seams.

HINT:
For easier nailing
stand on frame.

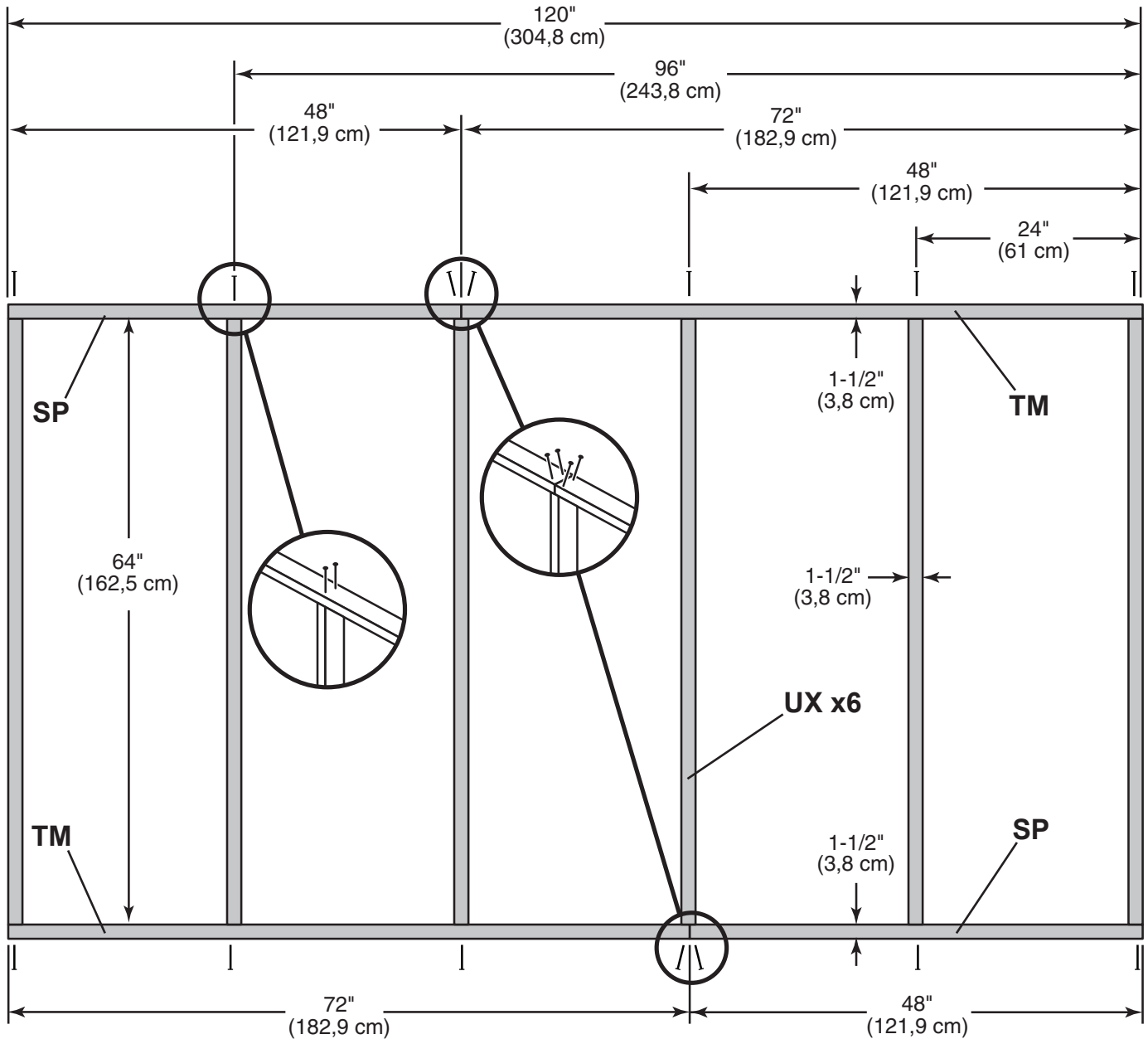
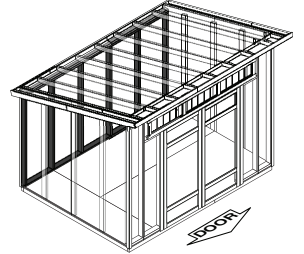
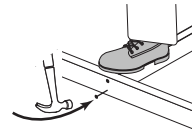

BACK WALL PANELS

PARTS REQUIRED:

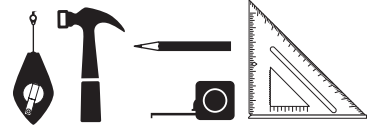
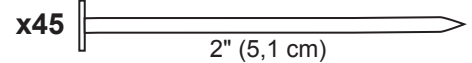

Install all wall panels with the primed side facing up.

 Ensure your wall frame is square by installing one panel and squaring frame.

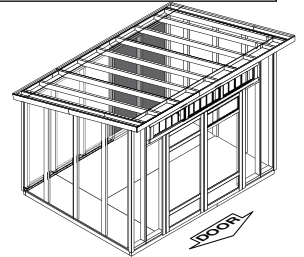

2 Install 48 x 72" panel onto wall frame flush to top of frame, as shown. Use the gauge block to mark the 3/4" measurement on the wall stud. Secure panel with (2) 2" nails in the corners (**Fig. A**).

3 Move to the opposite end. Using the long edge of the panel as a lever, move the panel side-to-side until you have a 3/4" measurement on the wall stud. Secure corner with (2) 2" nails (**Fig. B**). Secure the panel using 2" nails spaced 6" apart on edges and 12" apart inside panel.

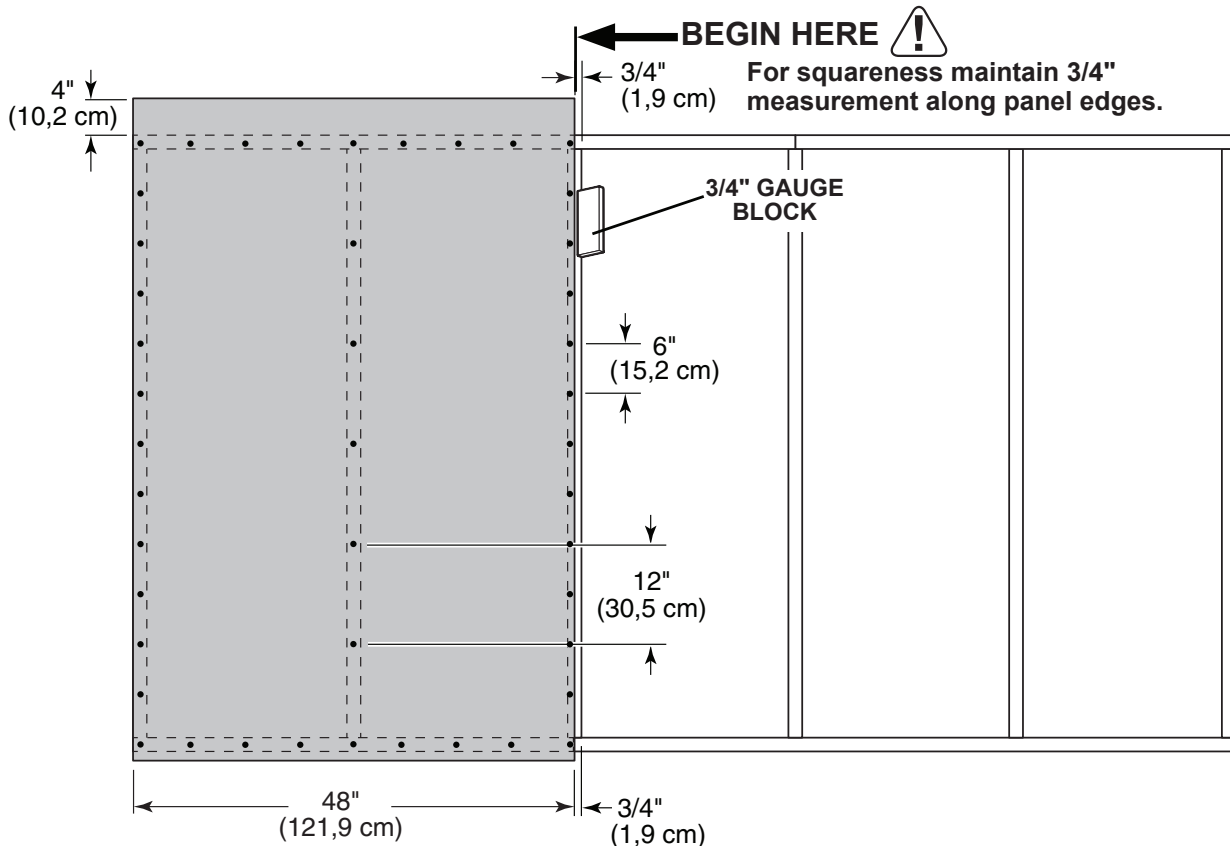
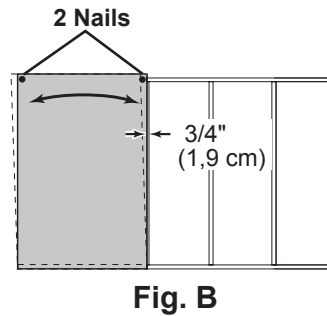
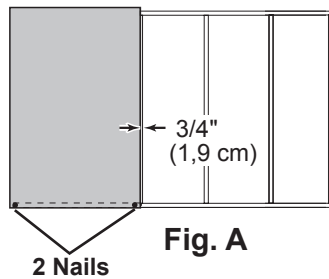

BACK WALL PANELS

PARTS REQUIRED:

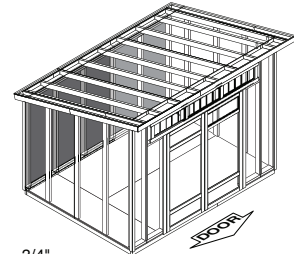
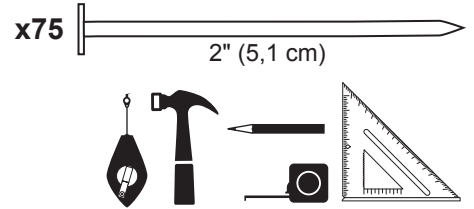
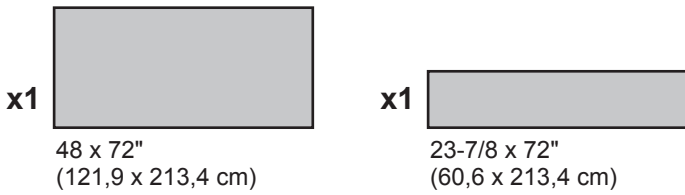

 For squareness maintain 3/4" measurement along panel edges.

4 Install center 48" x 72" panel on frame flush to installed panel.

Secure with 2" nails spaced 6" apart on edges and 12" apart inside panel.

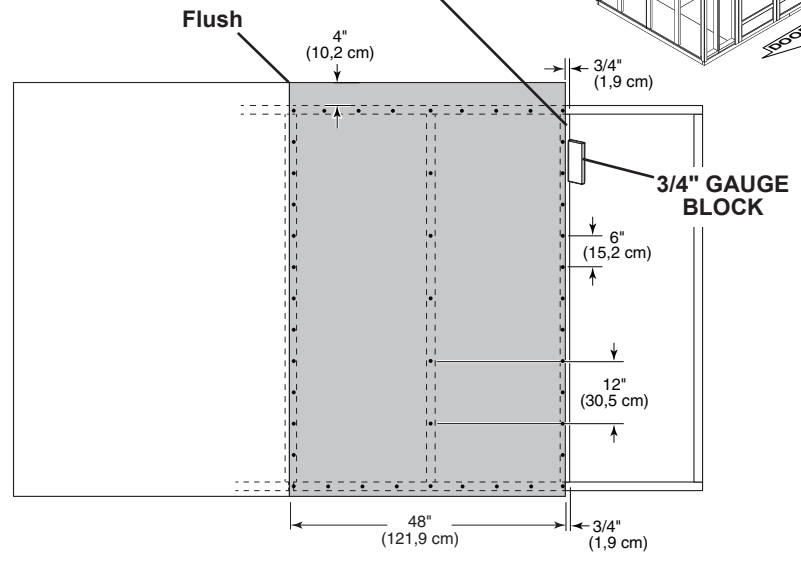

5 Install 23-7/8" x 72" panel on frame, flush to installed panel.

Secure with 2" nails spaced 6" apart on edges and 12" apart inside panel.

 For squareness maintain flush along panel edges.

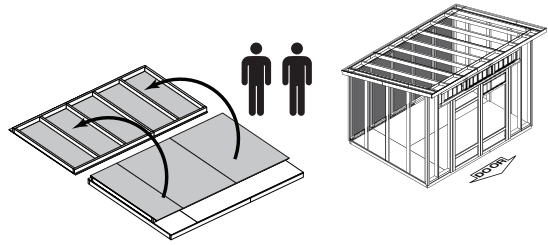
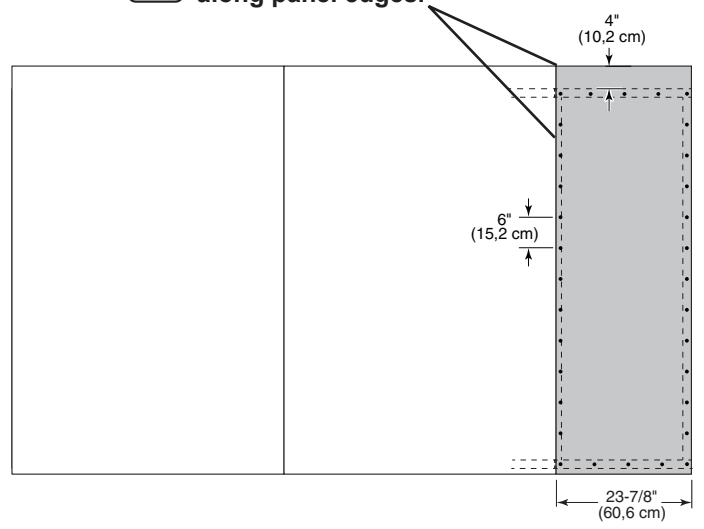

Carefully flip the wall over.



Your back wall is now installed.

FRONT WALL FRAME

PARTS REQUIRED:

- x1 **RD** 2 x 4 x 16-1/2" (5,1 x 10,2 x 41,9 cm) x2 **RR** 2 x 4 x 28" (5,1 x 10,2 x 71,2 cm)
- x1 **BMA** 2 x 4 x 45-5/8" (5,1 x 10,2 x 115,8 cm)
- x2 **UM** 2 x 4 x 68" (5,1 x 10,2 x 172,7 cm)
- x1 **BNA** 2 x 4 x 74-1/4" (5,1 x 10,2 x 188,6 cm)
- x4 **BLA** 2 x 4 x 86" (5,1 x 10,2 x 218,4 cm)
- x1 **UN** 2 x 4 x 94-1/2" (5,1 x 10,2 x 240,1 cm)

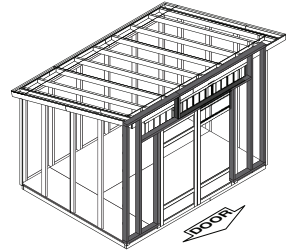
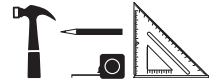
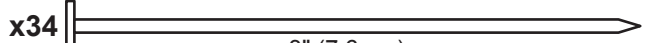

✓ BEGIN

- 1 Arrange parts on edge on floor. Measure and mark.
Secure with (2) 3" nails at each mark and (4) 3" nails at seam.

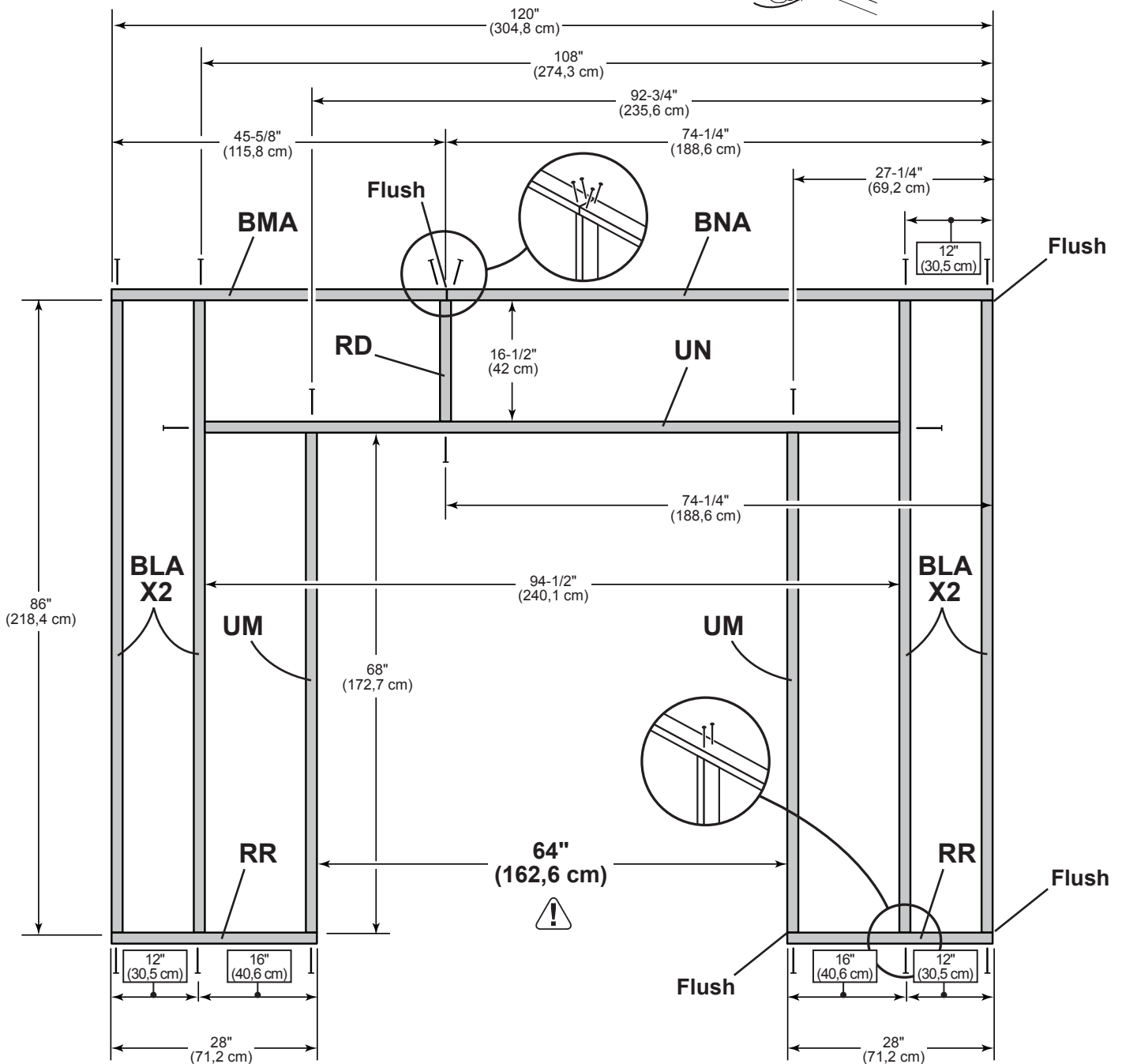

FRONT WALL FRAME

PARTS REQUIRED:

x3 **RD** 2 x 4 x 16-1/2" (5,1 x 10,2 x 41,9 cm)

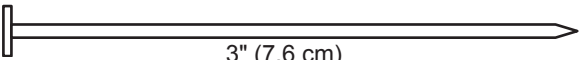
x12  3" (7,6 cm)

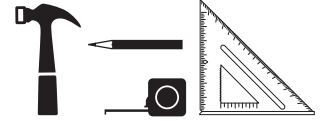

2 Install parts **RD** on edge as shown. Measure and mark.

Secure with (2) 3" nails at each mark.

HINT:  For easier nailing stand on frame.

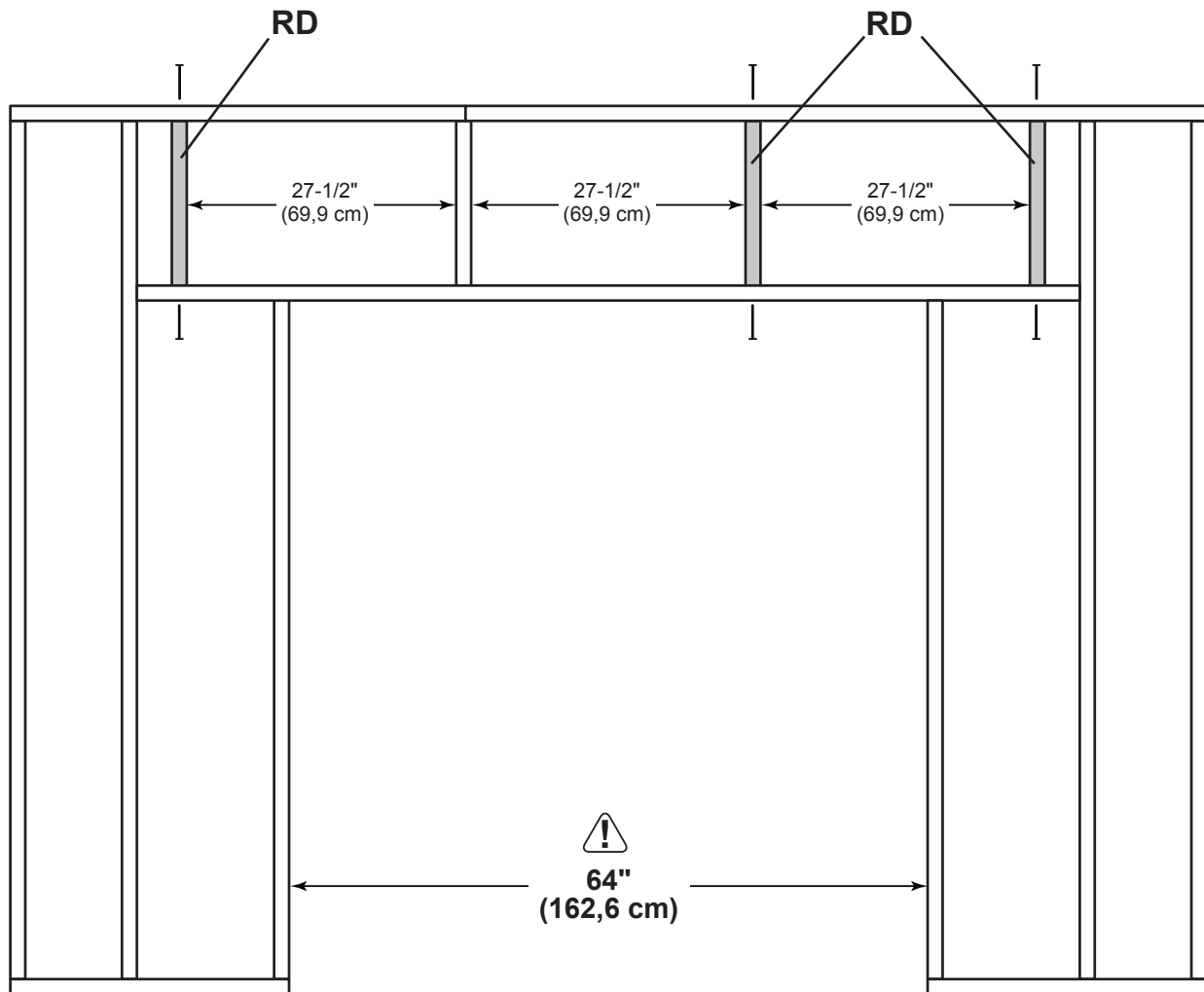
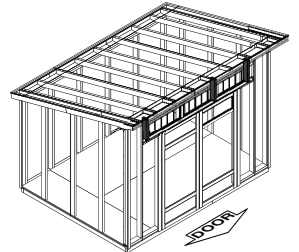
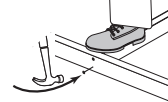

Your front wall frame is now assembled.

FRONT WALL PANELS

PARTS REQUIRED:

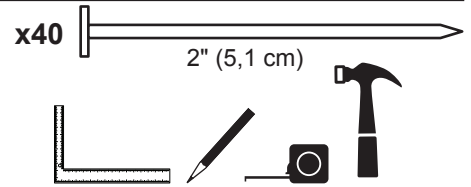
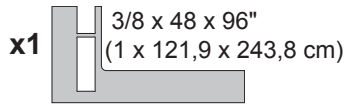

Install all wall panels with the primed side facing up.

 **Handle panels with care to avoid breakage.**

- 1** Install 48" x 96" left panel primed side up onto wall frame centered in door opening, as shown.
 - Ensure top of panel is overhanging the top of frame by 6".

 Hold the 3/4" measurement along left edge of panel. Use a gauge block.

- 2** Secure panel with (2) 2" nails spaced 6" apart. Maintain 64" (162,5 cm) measurement between studs and square frame.

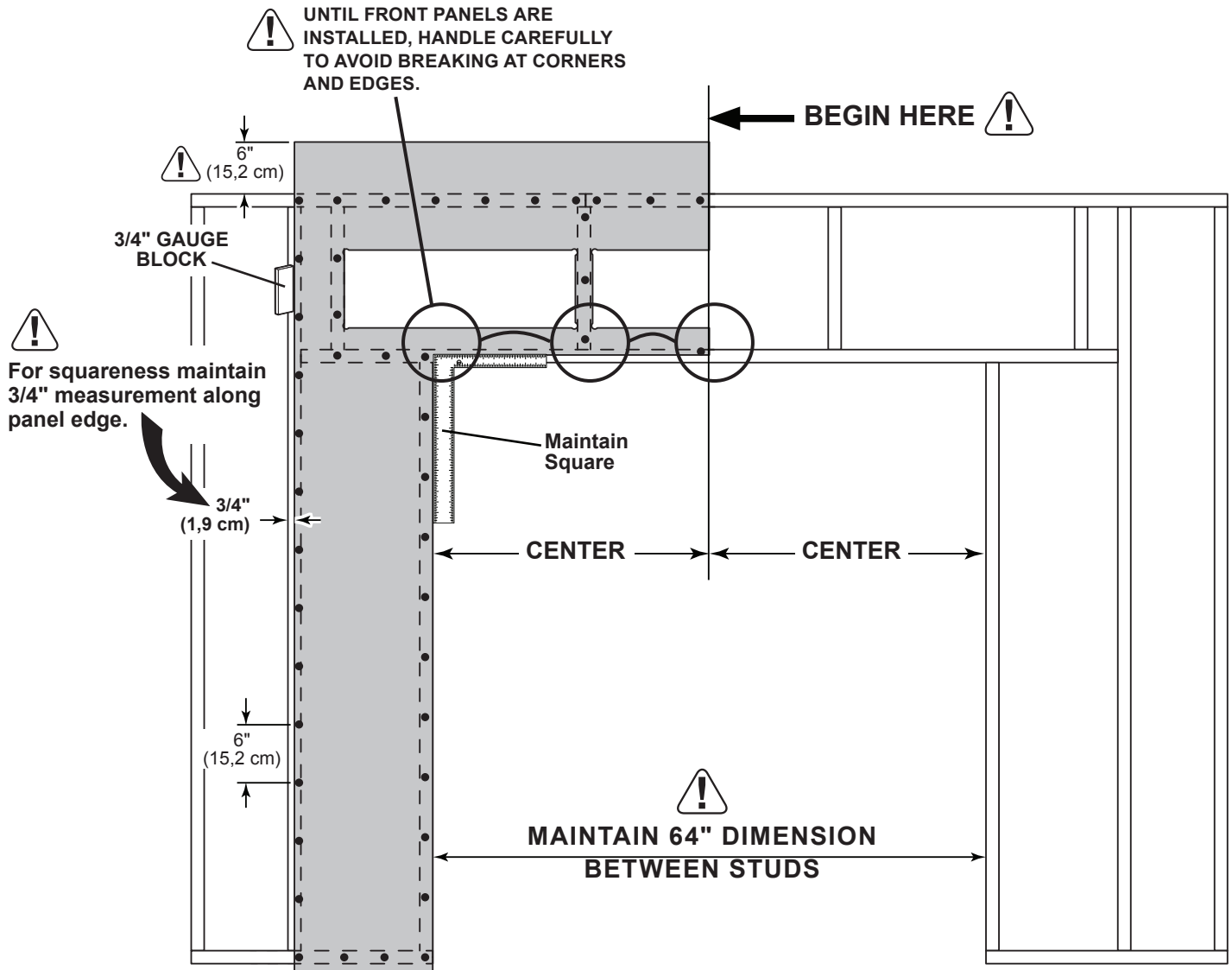
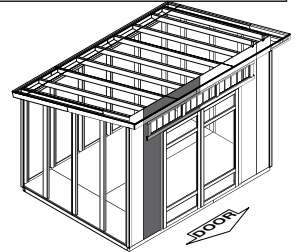

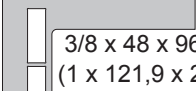

FRONT WALL PANELS

PARTS REQUIRED:

x1  3/8 x 48 x 96"
(1 x 121,9 x 243,8 cm)

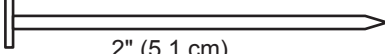
 3/4" GAUGE BLOCK

x40  2" (5,1 cm)

x2  3" (7,6 cm)

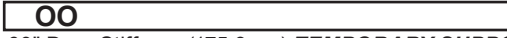
x1  OO
69" Door Stiffener (175,3 cm) **TEMPORARY SUPPORT**



3 Install 48 x 96" right panel flush to left panel.

 Hold the 3/4" measurement along right edge of panel. Use a gauge block. Secure panel with (2) 2" nails spaced 6" apart. Maintain 64" (162,5 cm) measurement between studs and square frame.

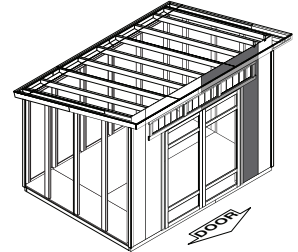

4 Install OO as a brace to maintain 64" (162,6 cm) opening. Secure with (2) 3" screws.

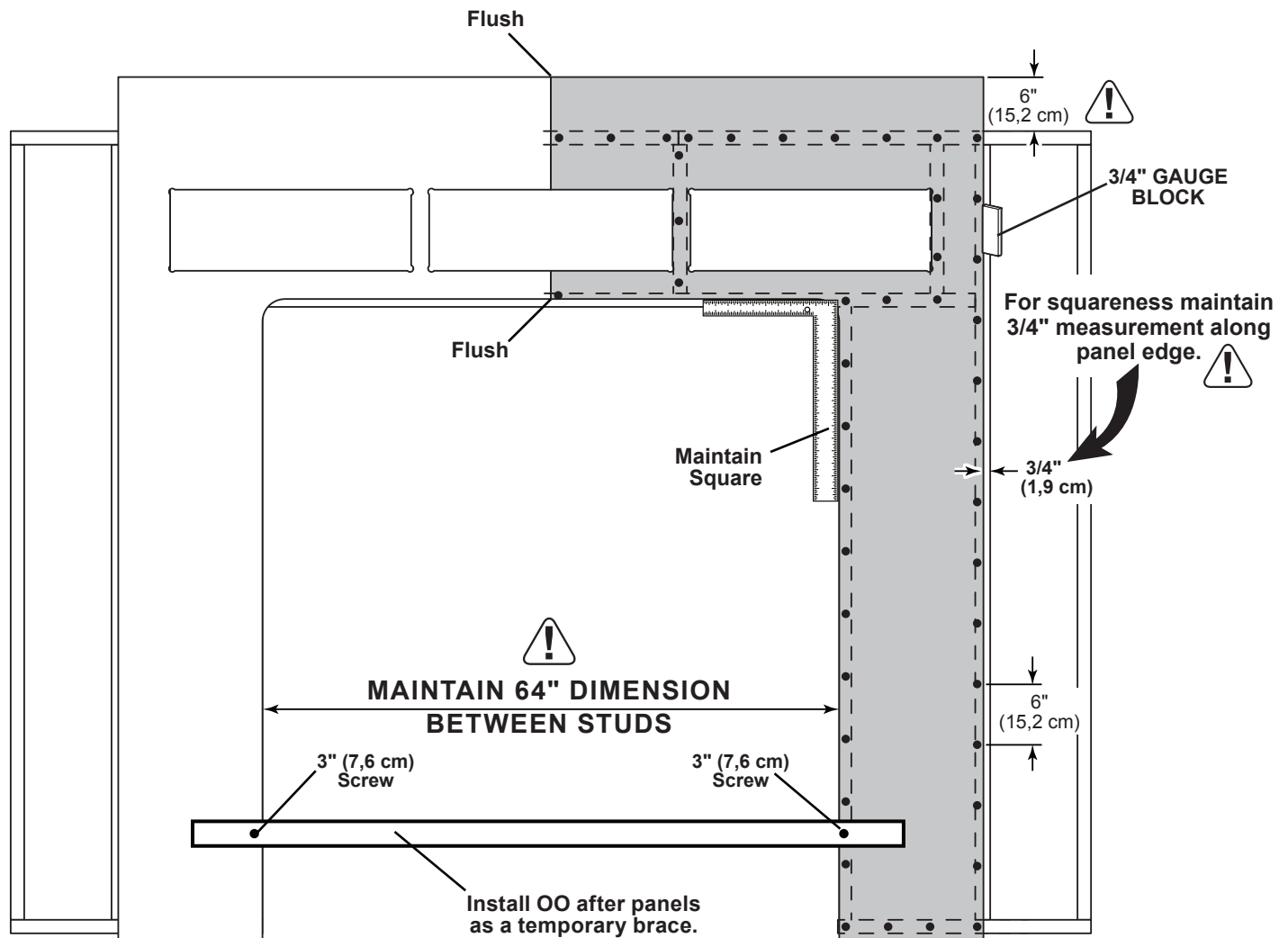

FRONT WALL PANELS

PARTS REQUIRED:

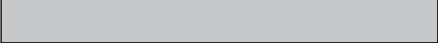
x2 
3/8 x 11-7/8 x 96" (1 x 30,5 x 243,8 cm)

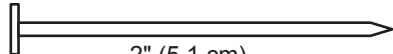
x60  2" (5,1 cm)



- 5** Install 11-7/8 x 96" panel onto wall frame flush to installed panel.
• **Ensure top of panel is overhanging the top of frame by 6".**

Secure the panel with 2" nails spaced 6" apart on edges.

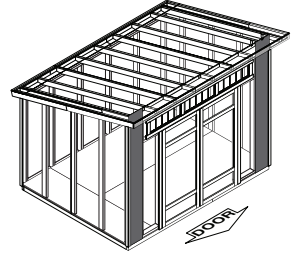

Repeat step 5 to install the right panel.

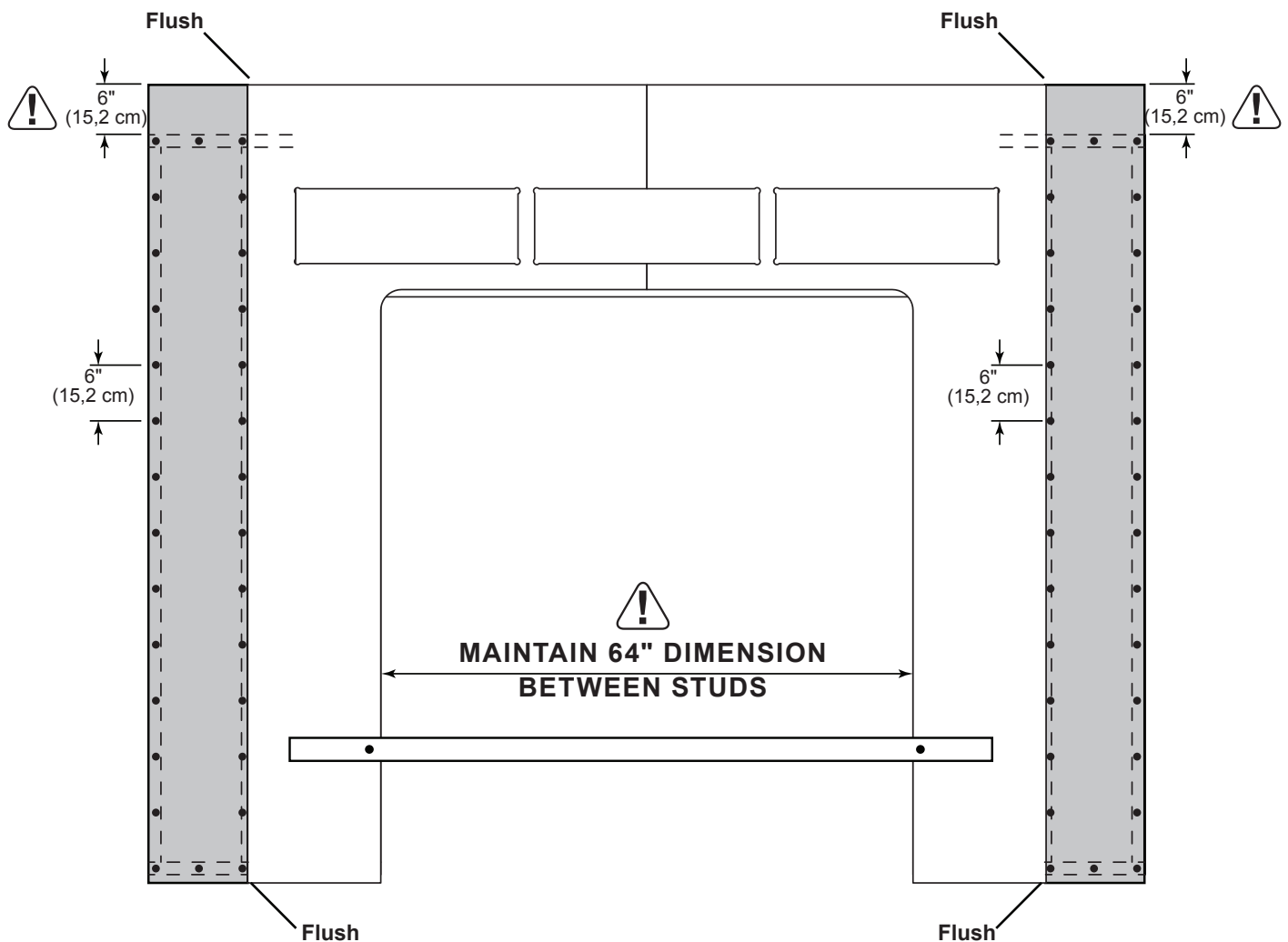

Your front wall is now assembled.

Carefully flip the wall over.

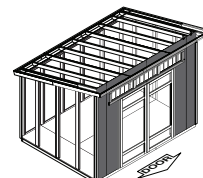
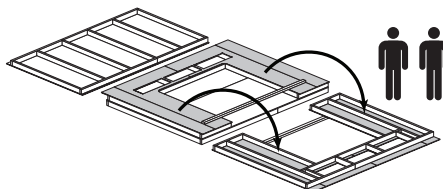

BACK WALL INSTALLATION

PARTS REQUIRED:

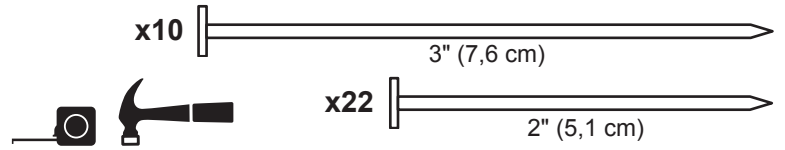

✓ BEGIN

- 1 Center back wall assembly on the 120" floor dimension.

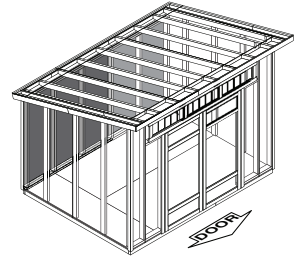
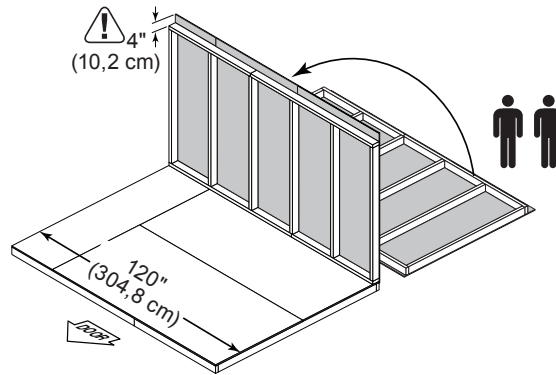

- 2 Secure lower edge of panel to floor frame with 2" nails spaced 6" apart. Angle nail into floor frame (**Fig. A**).

- 3 Secure side wall bottom plate to floor with 3" nails (**Fig. A**).

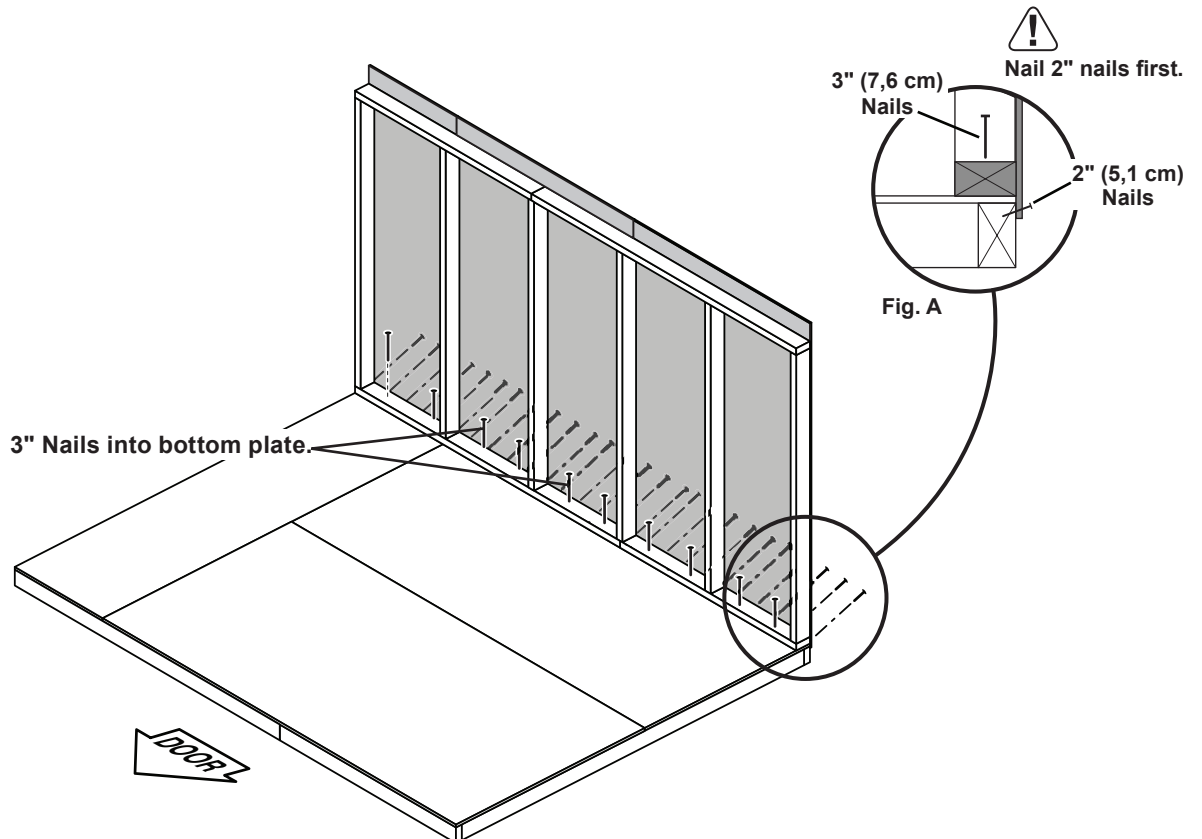

Your back wall is now standing.

FRONT WALL INSTALLATION

PARTS REQUIRED (TEMPORARY):

x2 **BOA**
2 x 4 x 93-3/16" (5,1 x 10,2 x 236,7 cm)



x8 3" (7,6 cm)
x4 3" (7,6 cm)
x10 2" (5,1 cm)

✓ BEGIN

- Center front wall assembly on the 120" front floor dimension.
- Use (2) **BOA** as temporary braces.
Level wall and secure **BOA** with (2) 3" screws.

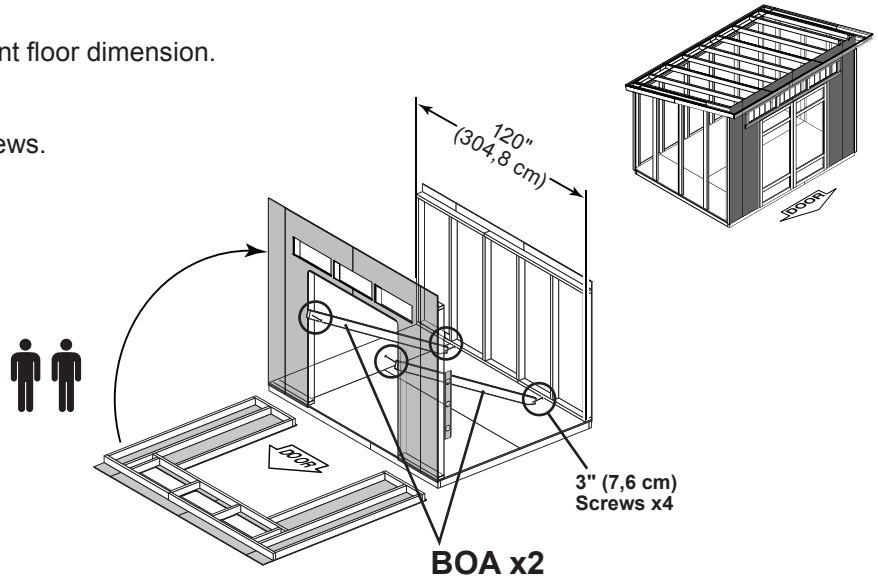

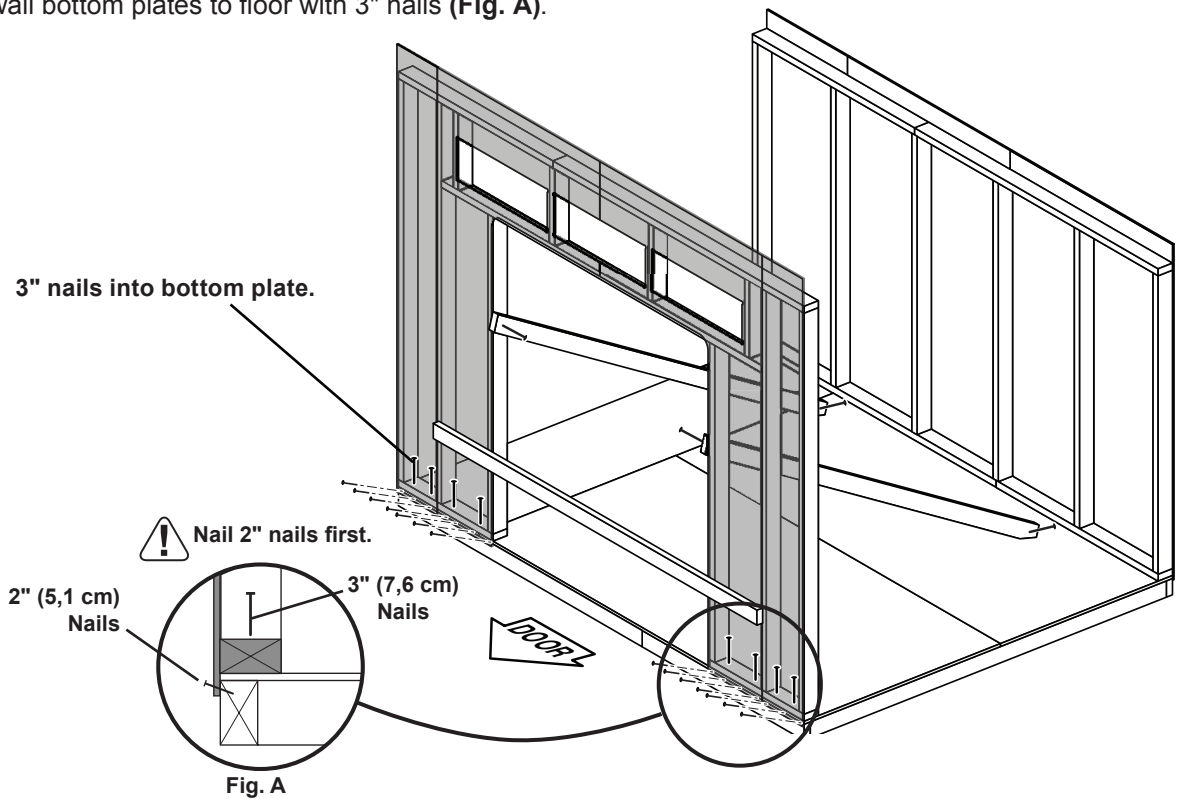

- Secure lower edge of panel to floor frame with 2" nails spaced 6" apart.
Angle nail into floor frame (**Fig. A**).
- Secure front wall bottom plates to floor with 3" nails (**Fig. A**).



Your front wall is now standing.

WALL DOUBLERS

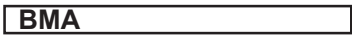
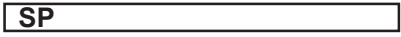
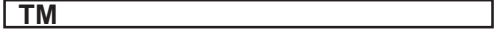
PARTS REQUIRED:

- x1 **BMA**  2 x 4 x 45-5/8" (5,1 x 10,2 x 115,8 cm)
- x1 **SP**  2 x 4 x 48" (5,1 x 10,2 x 122 cm)
- x1 **TM**  2 x 4 x 72" (5,1 x 10,2 x 182,9 cm)
- x1 **BNA**  2 x 4 x 74-1/4" (5,1 x 10,2 x 188,6 cm)

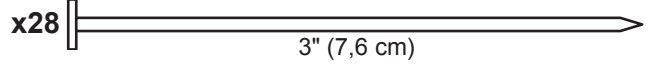

✓ BEGIN

- 1 Orient parts on flat side, on top of back wall frame.
Secure with (2) 3" nails at each stud and (4) 3" nails at seam.

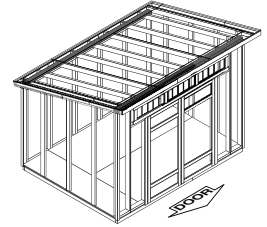

⚠ ENSURE DOUBLERS ARE FLUSH.

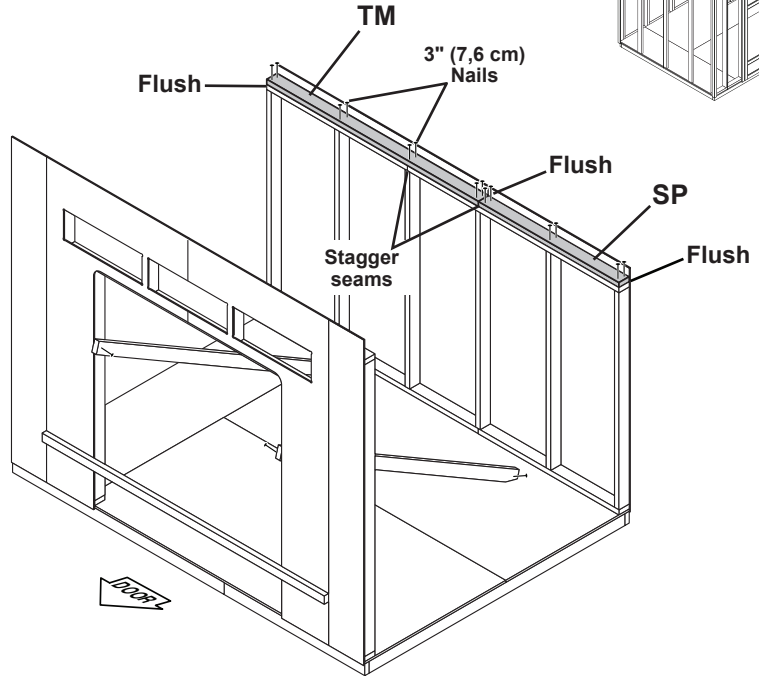

- 2 Orient parts on flat side, on top of front wall frame.
Secure with (2) 3" nails as shown and (4) 3" nails at seam.

⚠ ENSURE DOUBLERS ARE FLUSH.

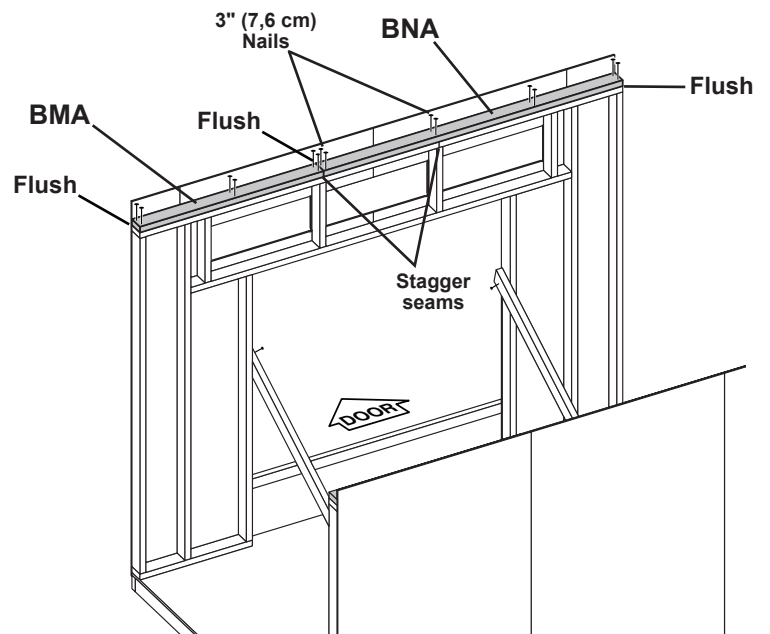

Your doublers are now installed.

OUTER RAFTER INSTALLATION

PARTS REQUIRED:

x2 **BOA**
2 x 4 x 93-3/16" (5,1 x 10,2 x 236,7 cm)

x8  3" (7,6 cm)



✓ BEGIN

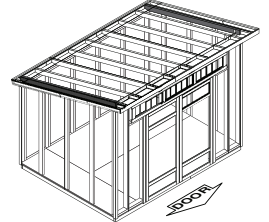

1 Rest one outer rafter on front and back wall doublers. Ensure rafter is flush to back wall panel (**Fig. A**) and flush to end of back wall doubler (**Fig. B**).

2 Secure back of outer rafter with (1) 3" screw installed centered into outer rafter end (**Fig. A**). Secure rafter with another 3" screw angled into inside of rafter (**Fig. B**).

! DO NOT OVER-DRIVE SCREW THROUGH PANEL.

3 Orient front of outer rafter flush to front wall panel (**Fig. C**) and flush to end of front wall doubler (**Fig. D**).

4 Secure front of outer rafter with (1) 3" screw installed centered into outer rafter end (**Fig. C**). Secure rafter with another 3" screw angled into inside of rafter (**Fig. D**).

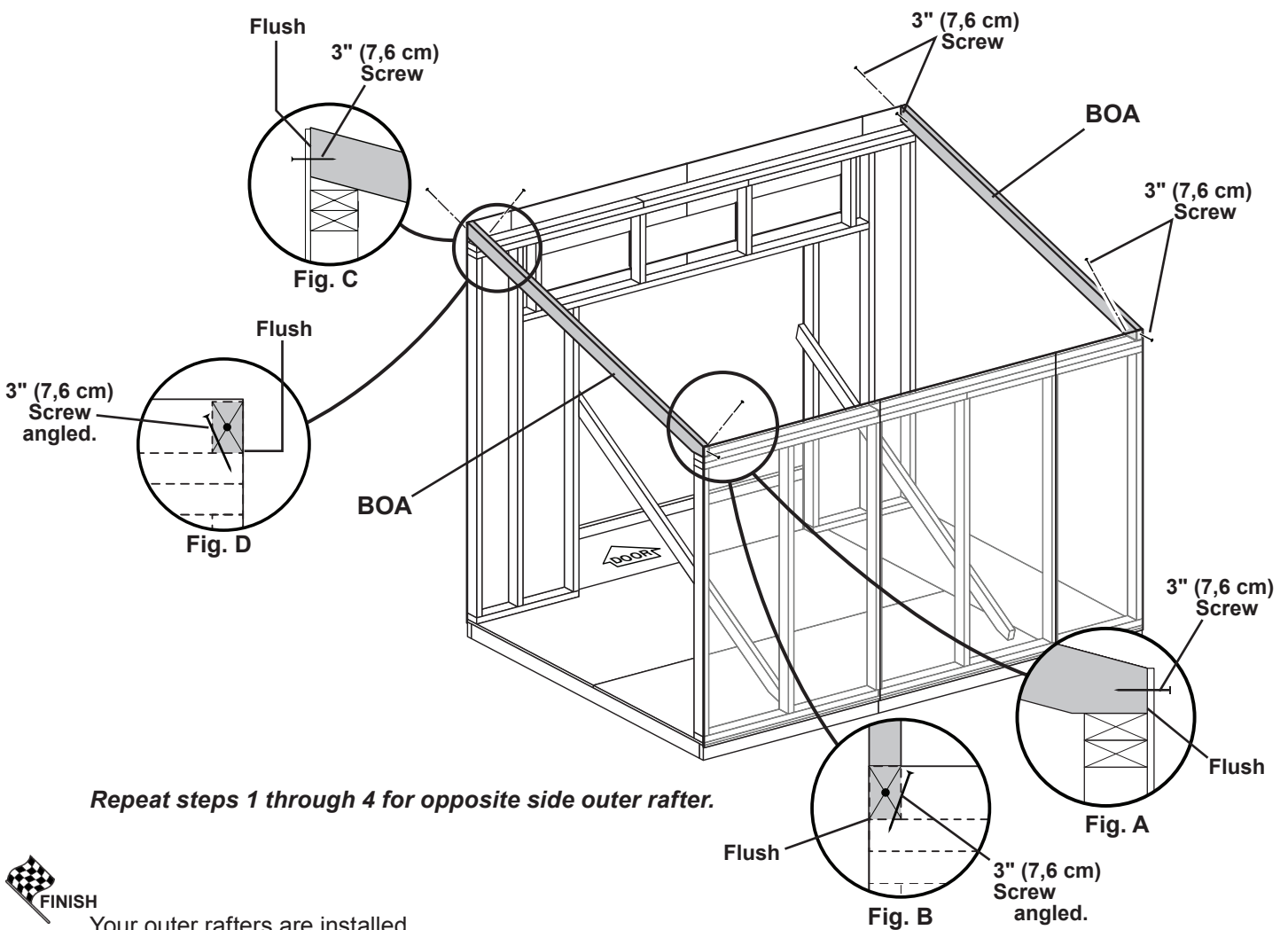

Repeat steps 1 through 4 for opposite side outer rafter.



Your outer rafters are installed.

Remove all temporary braces.

RAFTERS

PARTS REQUIRED:

x7 **BOA**
2 x 4 x 93-3/16" (5,1 x 10,2 x 236,7 cm)

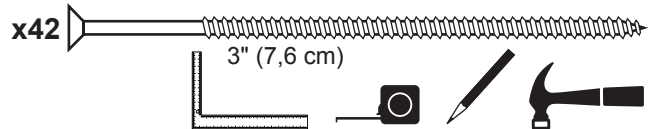

✓ BEGIN

- 1 Measure and mark location of each rafter.
- 2 Place rafter on front and back wall doublers. Line up rafter centered with marks. Ensure rafter is flush to back wall panel (**Fig. A**) and flush down on top of back wall doubler (**Fig. B**).
- 3 Secure back of rafter with 3" screw installed centered into outer rafter end (**Fig. A**).
! DO NOT OVER-DRIVE SCREW THROUGH PANEL.
- 4 Line up rafter centered with marks on front doubler. Ensure rafter is flush to front wall panel (**Fig. C**) and resting flush on top of front doubler (**Fig. C**). Secure front of rafter with 3" screw installed centered into outer rafter end (**Fig. C**).
- 5 Secure each end of rafter into doubler with 3" screws driven-in at an angle (**Fig. B, Fig. D**).

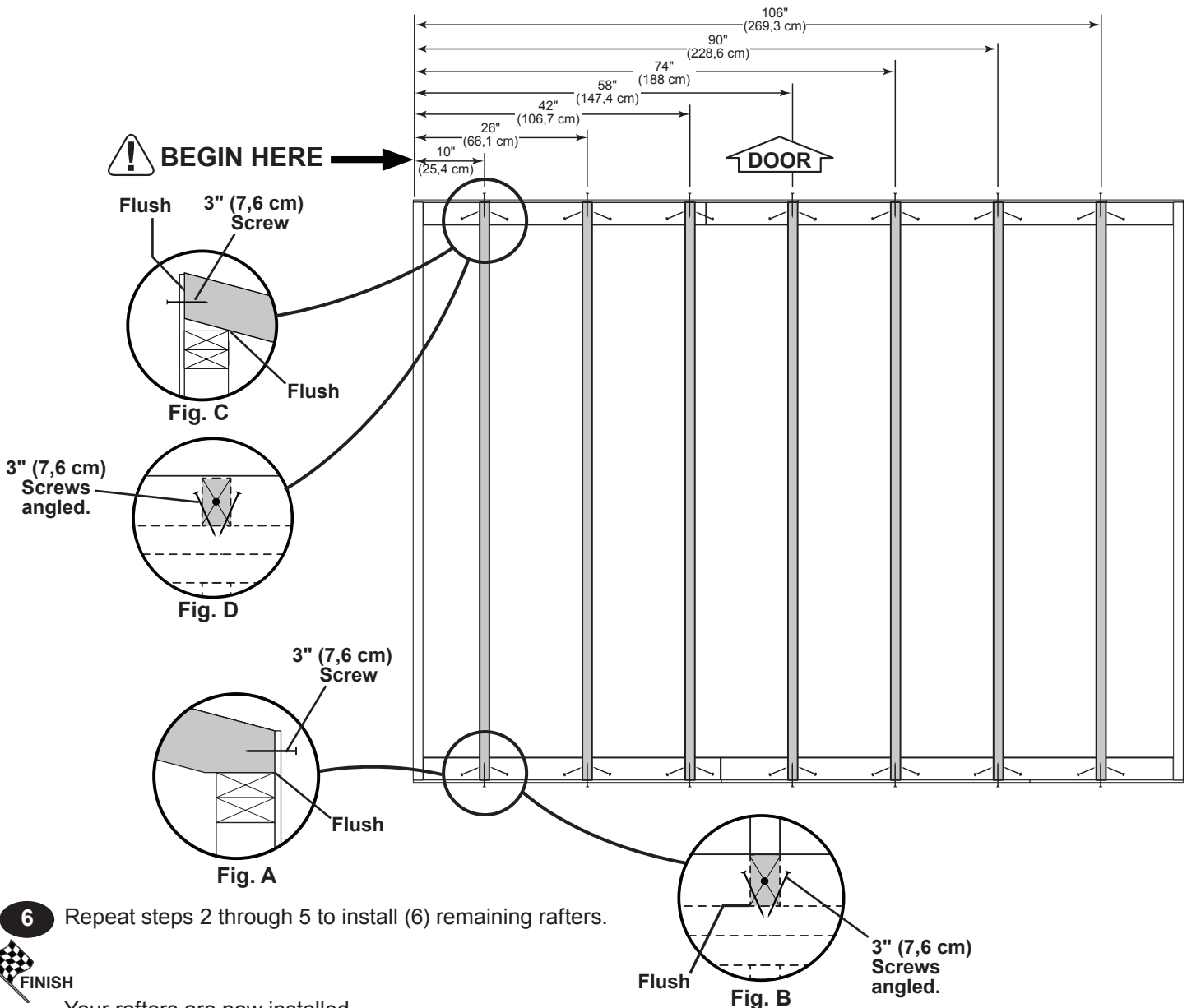
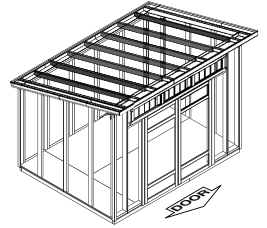

- 6 Repeat steps 2 through 5 to install (6) remaining rafters.



Your rafters are now installed.

RAFTER EXTENSIONS

PARTS REQUIRED:

x9 **BRA**
2 x 3 x 10-1/2" (5,1 x 7,6 x 26,7 cm)

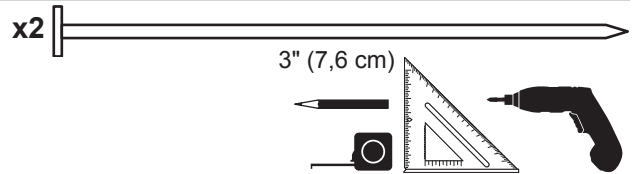

✓ BEGIN

1 Locate rafter extension above top of front wall panels (**Fig B**). Use another rafter extension (**BRA**) as a guide to line-up rafter extension with top of main rafter (**Fig A**).

2 Secure rafter extension with (2) 3" screws angled through front wall panel into **BRA** (**Fig. B**).

! DO NOT OVER-DRIVE SCREW THROUGH PANEL.

Repeat steps to install remaining (8) rafter extensions.

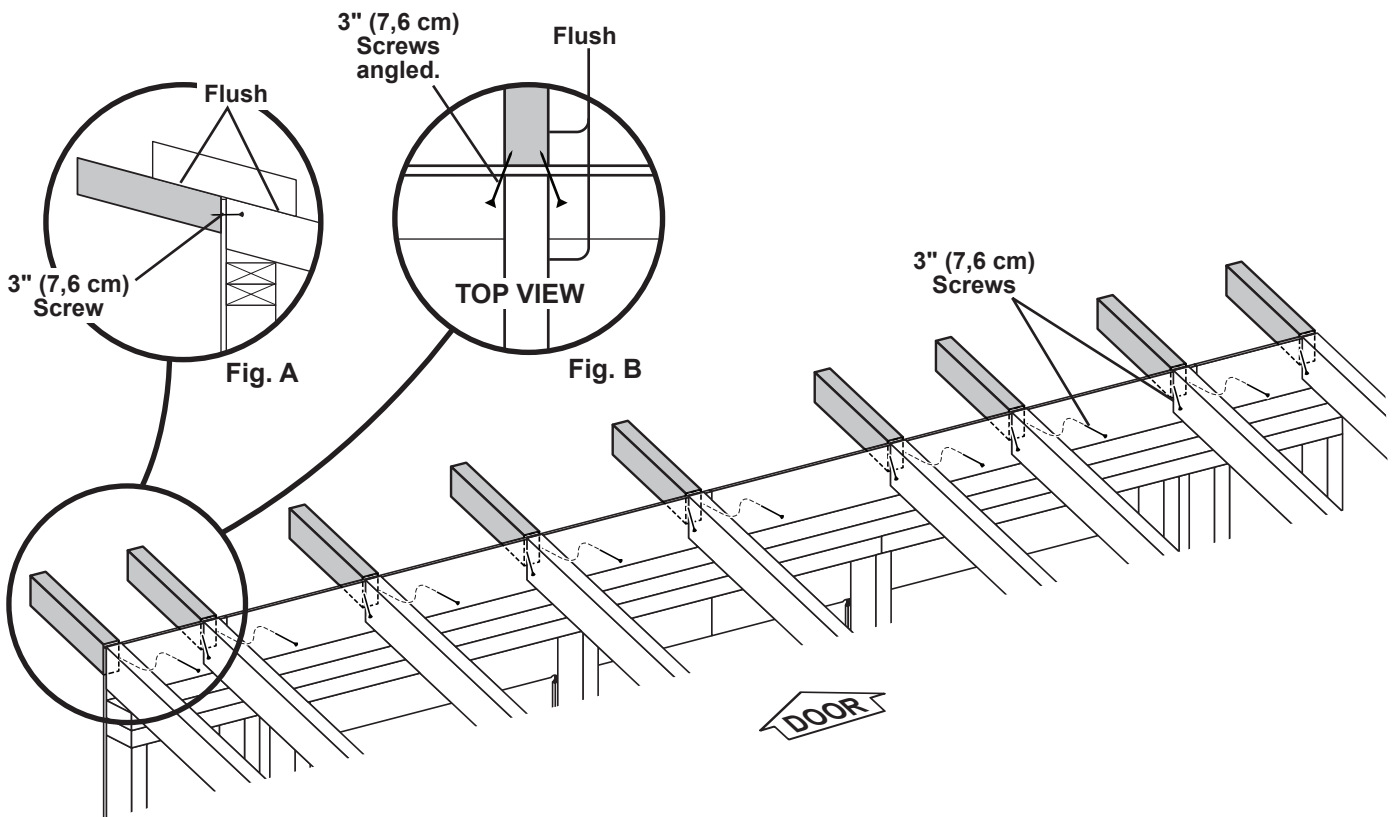
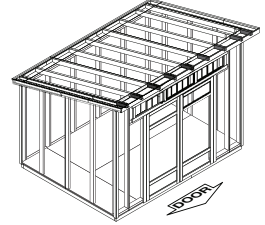

Your rafter extensions are now installed.

SIDE WALL PANELS

PARTS REQUIRED:

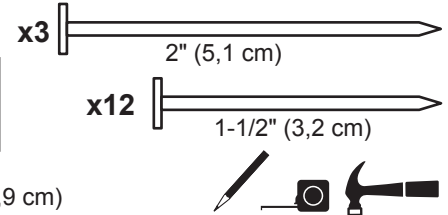
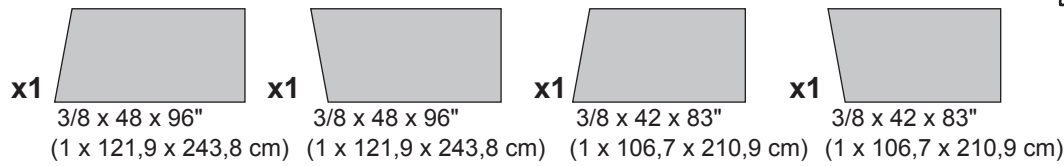

Install all wall panels with the primed side facing out.

✓ BEGIN

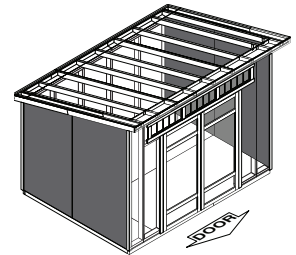

1 Place 48 x 96" panel onto side wall flush with front wall stud and flush to bottom front wall sheathing, with 1" overhang, as shown. Secure panel with (2) 2" nails in the corners (Fig. A). Ensure the measurement between the panel edges are the same along the entire length (Fig. B). Angle nails into floor frame (Fig. C).

2 Move to the top of panel. Using the long edge of the panel as a lever move the panel side-to-side until top of panel is flush with front wall stud. Secure upper corner with (1) 1-1/2" nail into rafter (Fig. D). Ensure 1" panel overhang at bottom of panel (Fig. D).

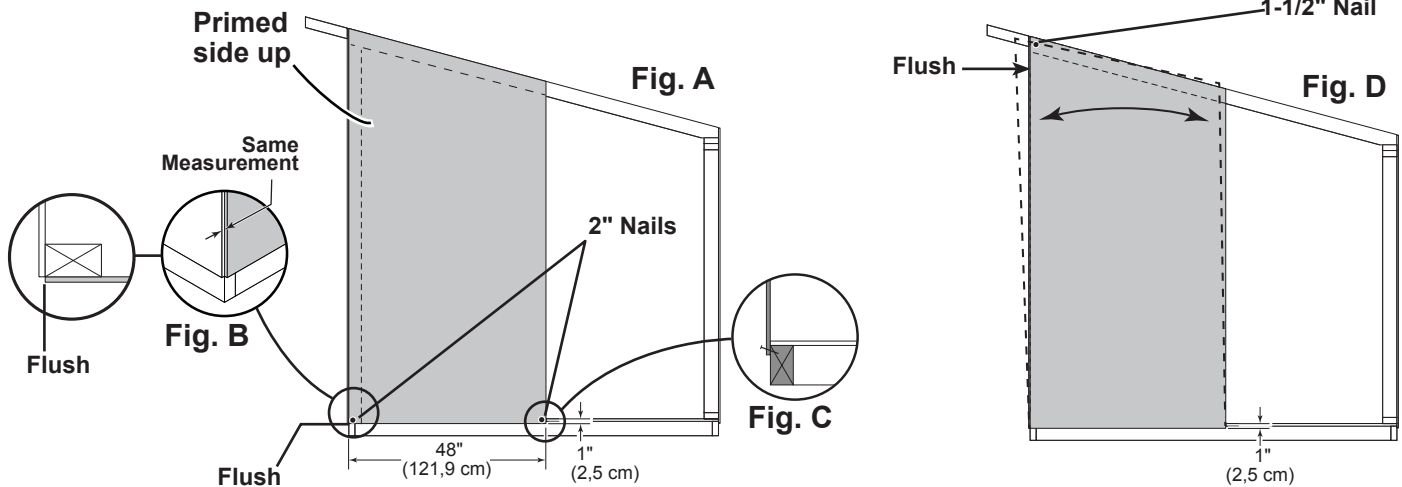

3 Place 42 x 83" panel onto side wall flush with bottom of 48 x 96" panel, as shown. Secure panel with 2" nails in three corners (Fig. E). Ensure the measurement between the panel edges are the same along the entire length (Fig. B). Angle nails into floor frame (Fig. C).

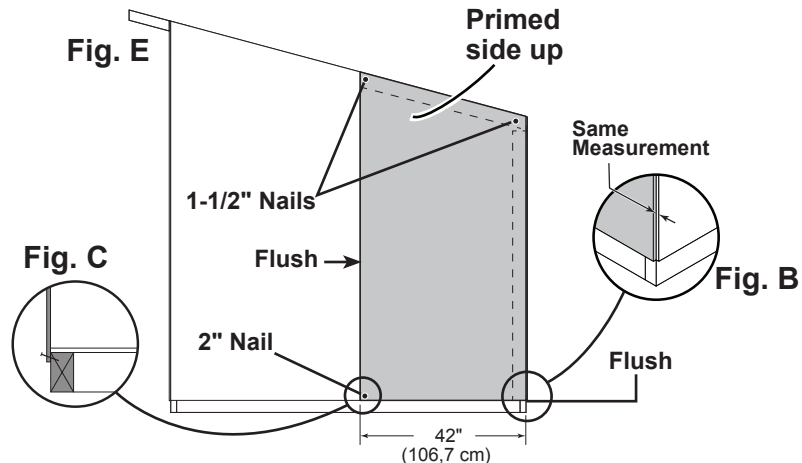

4 Repeat steps 1, 2 and 3 to install panels on the opposite side.

SIDE WALL PANELS (continued)

PARTS REQUIRED:



- 5 Secure lower edge of panel to floor with 2" nails spaced 6" apart. Angle nails into floor frame (**Fig. A**).
- 6 Secure side wall panels to rafter and wall studs with 1-1/2" nails spaced 6" apart.

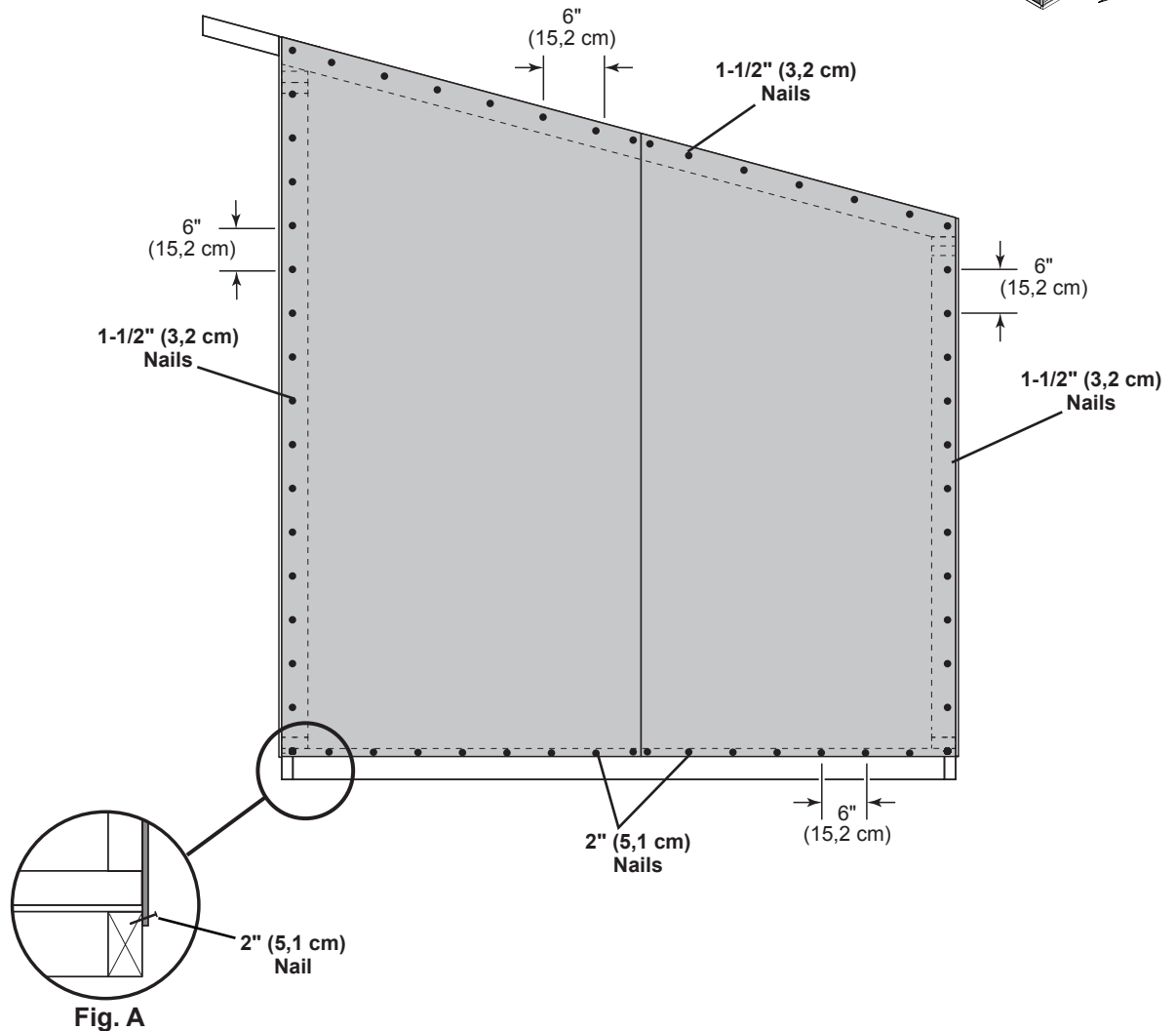
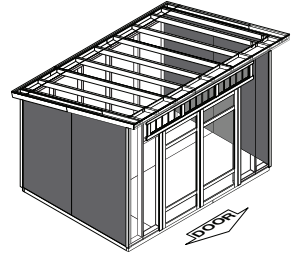

Repeat steps 1 and 2 to install the opposite side panels.

- 7 You have TEMPORARILY finished installing your side panels. Proceed to install SIDE WALL STUDS.

SIDE WALL STUDS

PARTS REQUIRED:

x2 **BFA**
2 x 4 x 72-5/8" (5,1 x 10,2 x 184,5 cm)

x2 **BJA**
2 x 4 x 79-1/8" (5,1 x 10,2 x 201,3 cm)

x2 **BKA**
2 x 4 x 85-1/2" (5,1 x 10,2 x 217,2 cm)

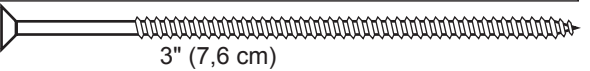
x18  3" (7,6 cm)

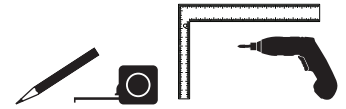

BEGIN

- 1 Install **BJA** centered at seam of side wall panels (**Fig A**). Use a square to ensure 90 degree squareness of studs (**BKA**, **BFA** and **BJA**).

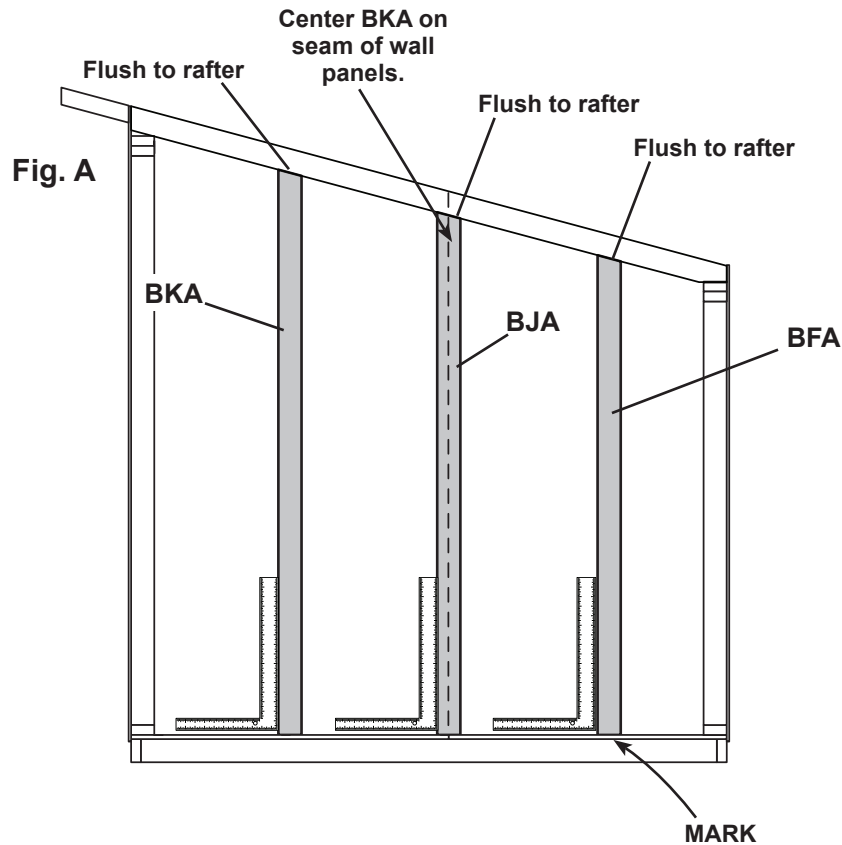
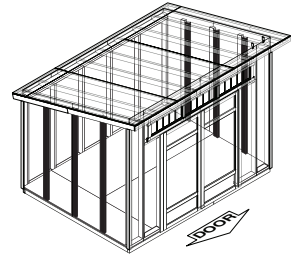

- 2 Mark locations of studs and ensure 90 degrees angle at top of each stud.

Secure side wall studs with 3" screws into end rafters and floor frame (**Fig B**).

Repeat steps 1 and 2 to install the opposite side's side wall studs.

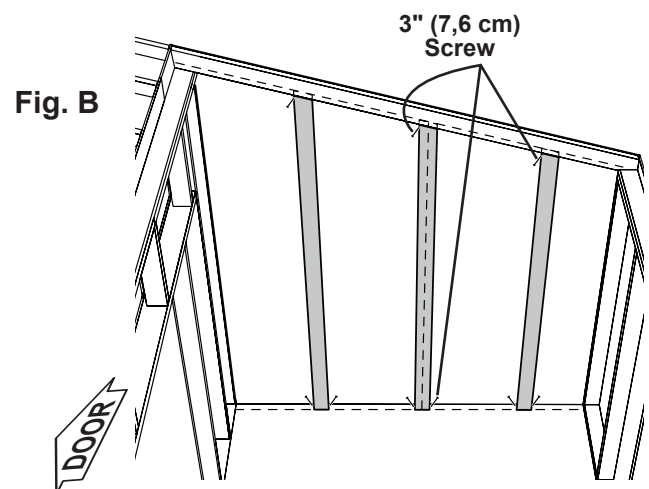

FINISH

Your side wall studs are now installed.

Proceed to completely secure the side wall panels.

SIDE WALL PANELS (continued)

PARTS REQUIRED:

x58 1-1/2" (3,2 cm)



- 8** Measure, align and mark side wall studs 24" from center of panel seam, and as shown.

Secure side wall panels to inside wall studs with 1-1/2" nails spaced 6" apart along panel seam and 12" apart in middle of panels as shown.

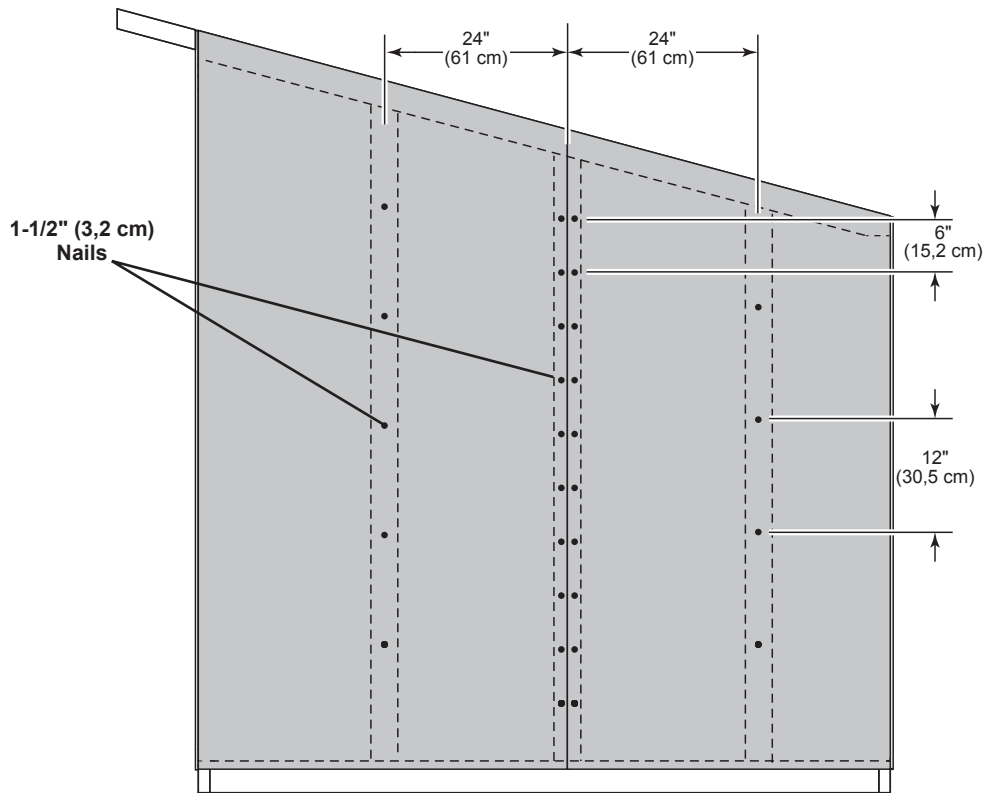
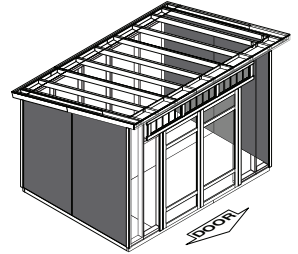

Repeat step 8 to secure the opposite side's panels.



Your side wall panels are now secured.

ROOF PANELS

PARTS REQUIRED:

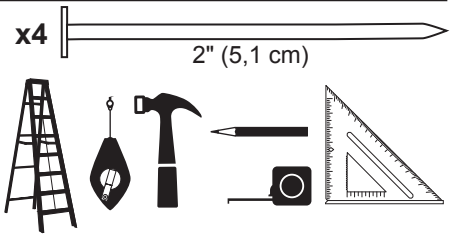
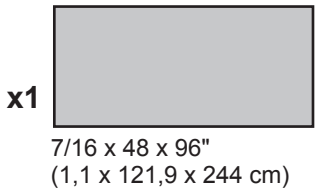

Install all roof panels with the rough side up (painted grid lines).

Roof panels may cause serious injury until securely fastened.

You must square the roof by attaching one panel first. You will use the panels' long edge as a lever to bring your roof into square. Commonly known as "racking".

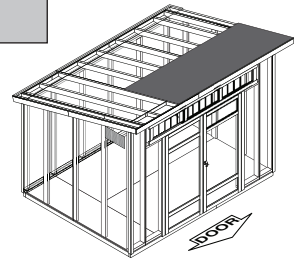

✓ BEGIN

- 1 Install the **48 x 96"** panel with $1/2"$ measurement overhanging the rafter extension (**Fig B**) and the panel is $3/4"$ along the the length of the rafter (**Fig. A**).

Secure panel with (2) nails as shown.

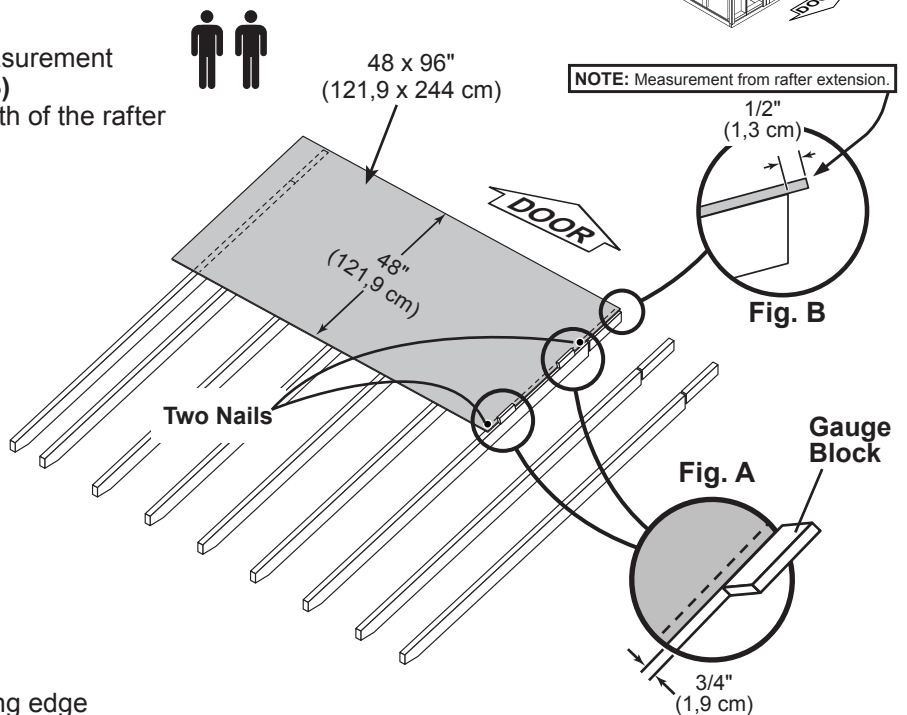

- 2 Move to the opposite end. Using the long edge of the panel as a lever move the panel side-to-side until the top corner is at $1/2"$ measurement overhanging the rafter extension (**Fig B**).

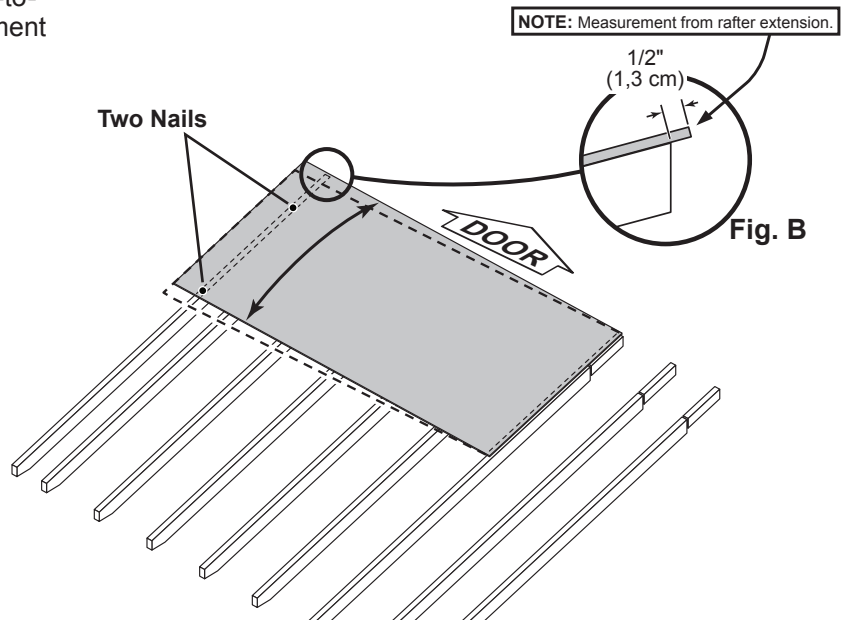

You may need to move your entire roof frame to make panel line up with $1/2"$ overhang measurement (**Fig. B**).

Secure panel with (2) 2" nails into rafters.



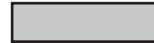
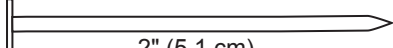

ROOF PANELS

PARTS REQUIRED:

x1  **x1**  **x1**  **x120**  2" (5,1 cm)

x1  (1,1 x 121,9 x 244 cm)

x1  (1,1 x 92,4 x 244 cm)

x1  (1,1 x 30,2 x 244 cm)

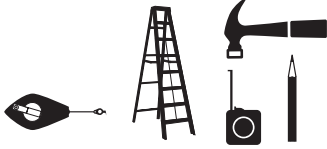

- 3** Secure the first **48 x 96"** roof panel with 2" nails spaced 6" apart on edge and 12" apart inside panel.

Install the second **48 x 96"** roof panel flush to first panel along edge and at both corners (**Fig. C, D**). Repeat nailing pattern.

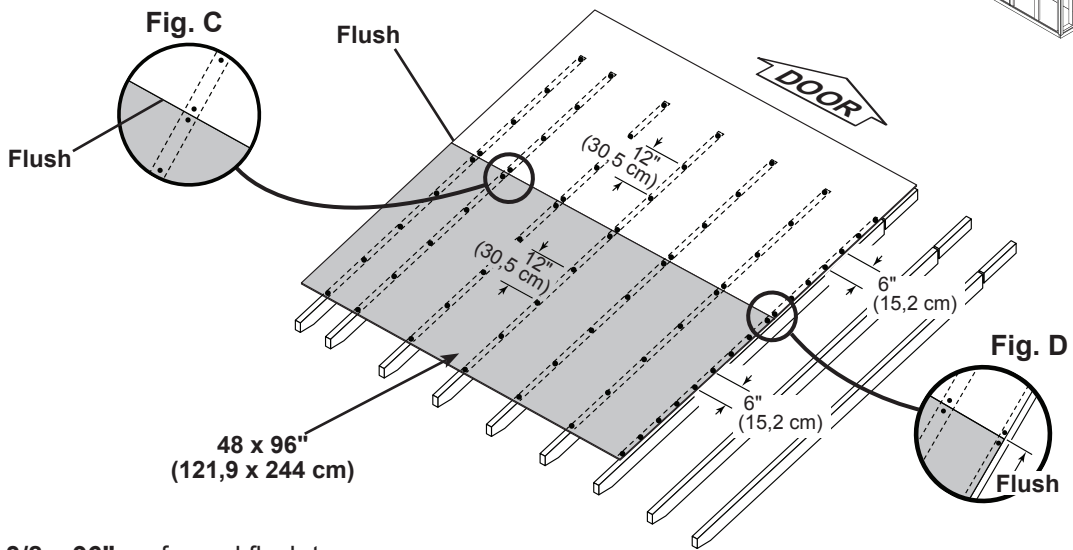
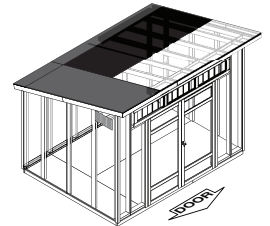

- 4** Install the **36-3/8 x 96"** roof panel flush to installed panels.

Secure with 2" nails spaced 6" apart on edge and 12" apart inside panel.

Ensure the **36-3/8 x 96"** roof panel overhang is at 1/2" (**Fig. B, E**).

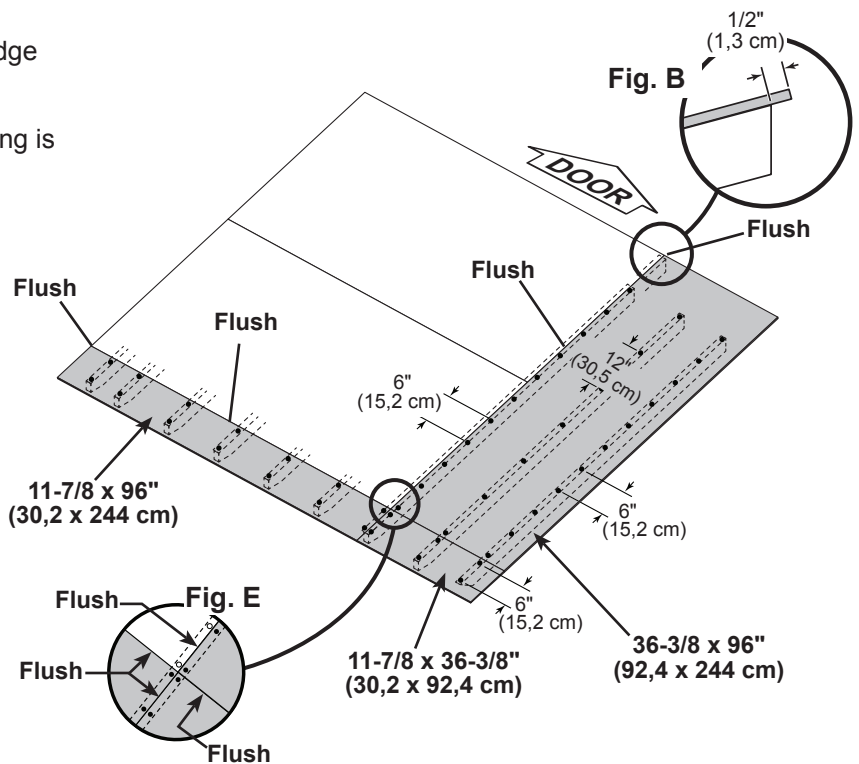

- 5** Secure the **11-7/8 x 96"** roof panel flush to installed panels (**Fig. E**).

Secure with 2" nails spaced 6" apart on edges.

- 6** Install the **11-7/8 x 36-3/8"** roof panel flush to installed panels (**Fig. E**).

Secure with 2" nails spaced 6" apart on edges.

ROOF PANELS

PARTS REQUIRED:

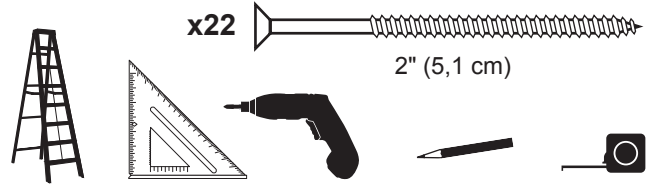

- 7** Line up each rafter extension 90 degrees square with roof rafters as shown. Secure rafter extensions with screws through roof panels (**Fig. A**).

-  Use 4 screws at roof panel seams (**Fig. B**).

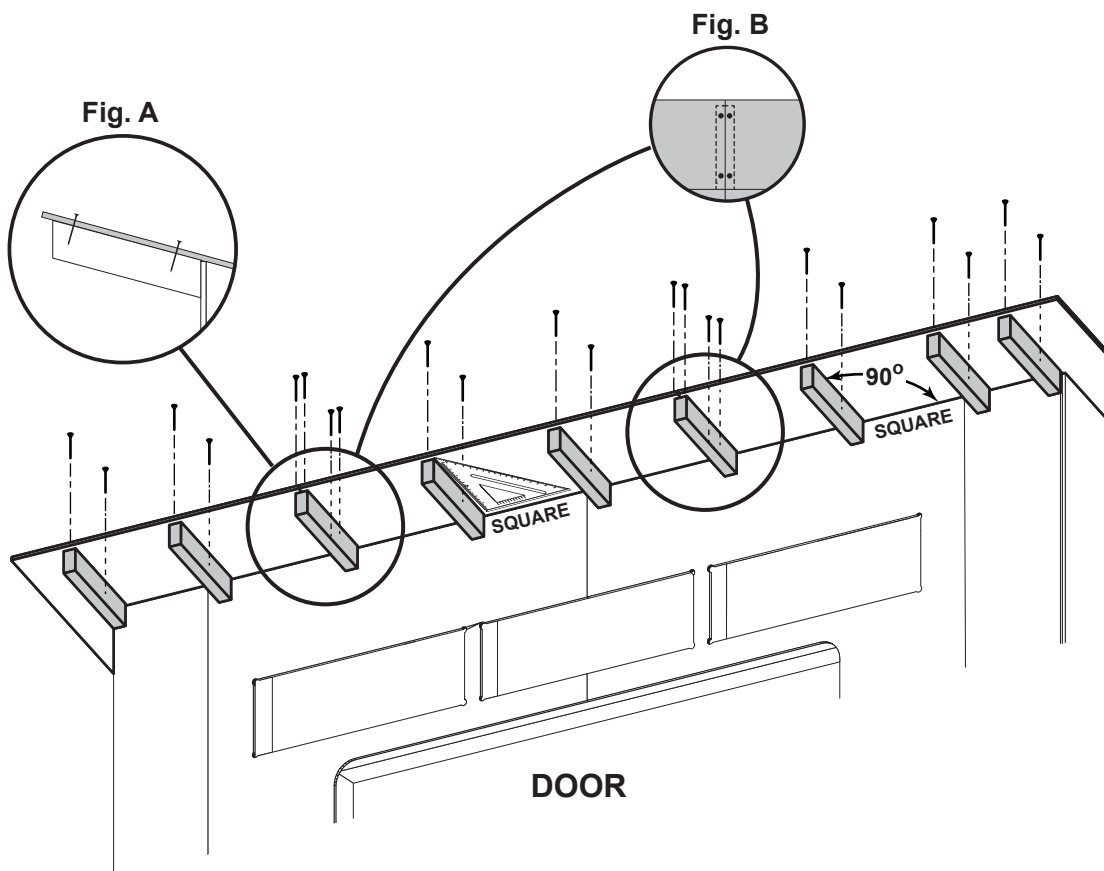
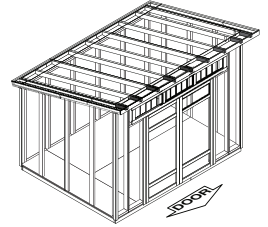

Your roof panels are now installed.

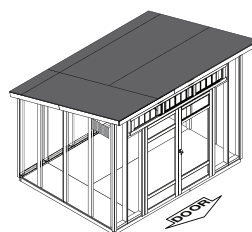

GABLE RAKE FRAMING

PARTS REQUIRED:

x2 **BPA**
1 x 3 x 33 - 1/8" (2,5 x 7,6 x 84,1 cm)

x2 **HJ**
1 x 3 x 72" (2,5 x 7,6 x 182,8 cm)

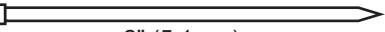
x16  2" (5,1 cm)



Install all trim with the primed side facing out.

✓ BEGIN

- 1 Align **BPA** edge flush with **BRA** (Fig A).
Secure with (3) 2" finishing nails (Fig B).
- 2 Install **HJ** flush with **BPA**.
Secure with (5) 2" finishing nails (Fig A, Fig B).

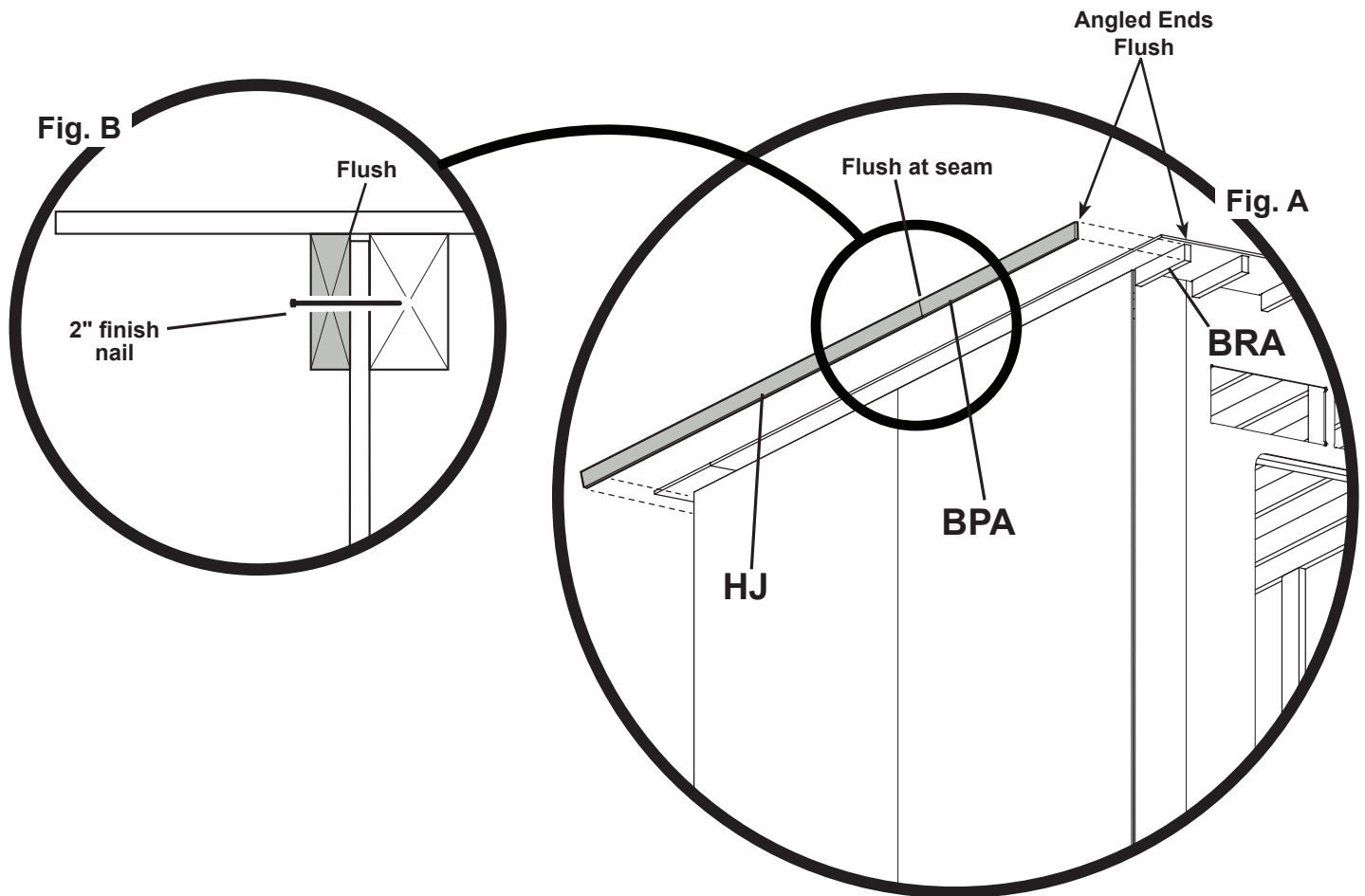
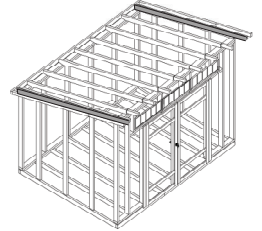

Repeat Steps 1-2 on opposite side.



Your gable rake framing is now installed.

FRONT EAVE FASCIA TRIM

PARTS REQUIRED:

x1 **BUA**
19/32 x 3-1/2 x 52 - 3/8" (1,5 x 8,8 x 133 cm)

x1 **BTA**
19/32 x 3-1/2 x 80" (1,5 x 8,8 x 203,2 cm)

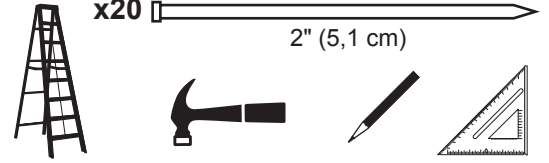

Install all trim with the primed side facing out.

✓ BEGIN

- 1 Fasten **BUA** to **BRA** (Fig. A, Fig. C). Extend **BUA** approximately 1/4" beyond roof panel (Fig. B). Secure **BUA** with 2" finishing nails (Fig. C).
- 2 Attach **BTA** to **BRA** (Fig. A, Fig. C) flush with **BUA**. Secure with 2" finishing nails. **BTA** extends approximately 1/4" beyond roof panel (Fig. D). Secure **BUA** and **BTA** ends to **BRA** with (4) 2" finishing nails (Fig. E).

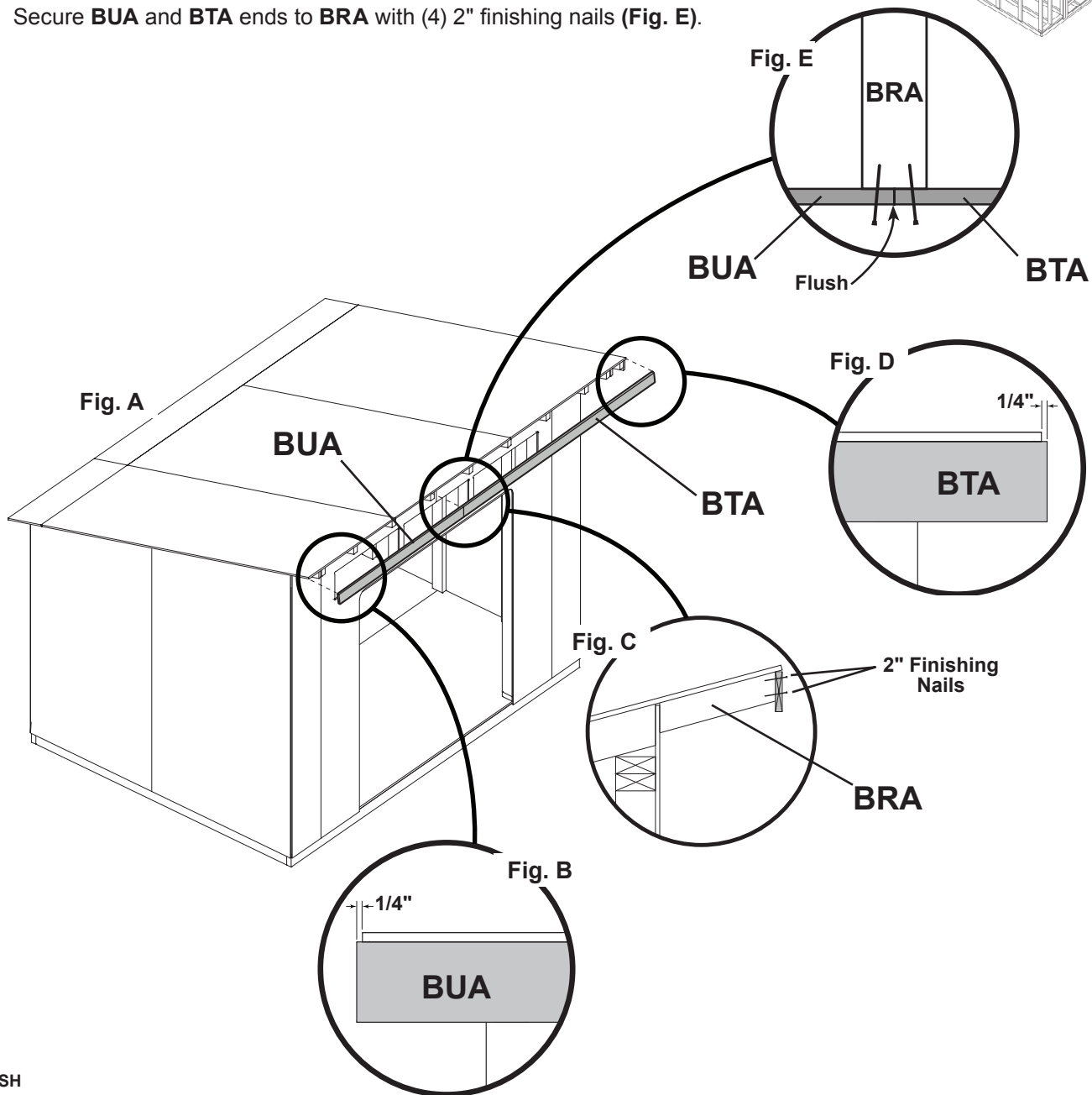
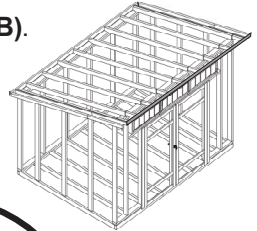

Your front eave trim is installed.

SIDE FASCIA TRIM ASSEMBLY

PARTS REQUIRED:

- x2 **BQA**
2 x 3 x 33-1/8" (5,1 x 7,6 x 84,1 cm)
- x2 **ZT**
19/32 x 3-1/2 x 48" (1,5 x 8,8 x 121,9 cm)
- x1 **BXL**
19/32 x 3 - 1/2 x 59 - 1/4" (1,5 x 8,8 x 150,4 cm)
- x1 **BXR**
19/32 x 3 - 1/2 x 59 - 1/4" (1,5 x 8,8 x 150,4 cm)
- x2 **OY**
2 x 3 x 72" (5,1 x 7,6 x 182,8 cm)

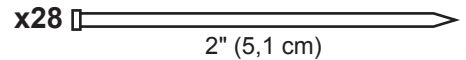

Install all trim with the primed side facing out.

✓ BEGIN

- 1 Build rear fascia assembly on a flat surface. Place **BQA** and **OY** end to end (**Fig. A**).

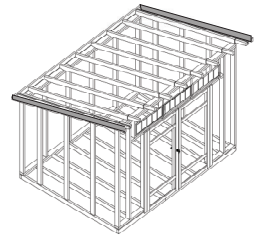
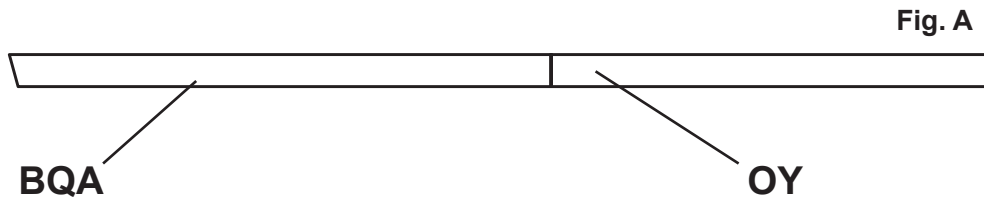

- 2 Place **BXR** and **ZT** flush with **BQA** and **OY**. Secure with 2" finishing nails, as shown (**Fig. B**, **Fig. C**).

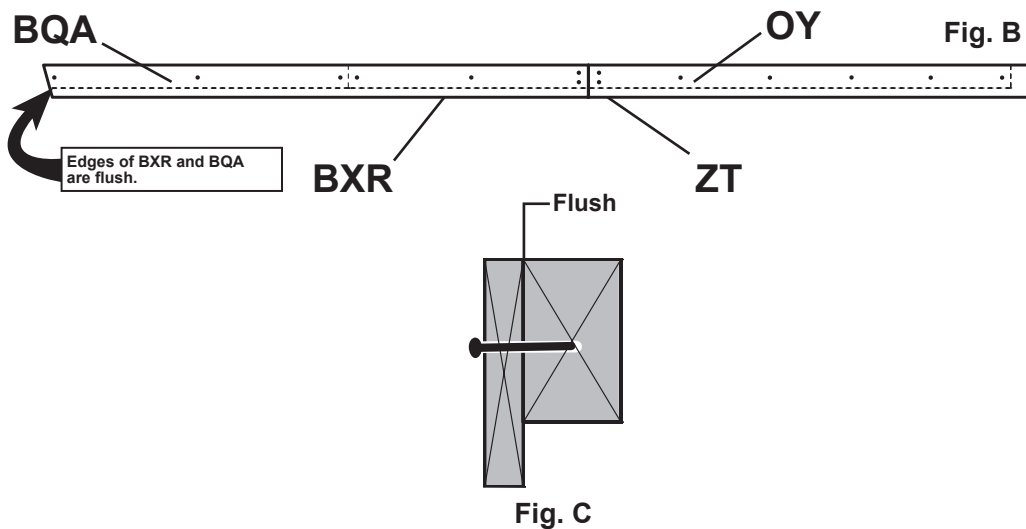

*Repeat steps for the opposite side using **BXL** and **ZT**.*



You have now finished assembling the side fascia trim.

SIDE FASCIA TRIM INSTALL

PARTS REQUIRED:

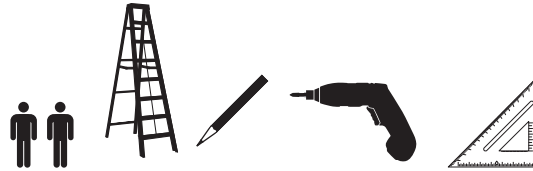

x4 2" (5,1 cm)

x12 2" (5,1 cm)

Install all trim with the primed side facing out.

✓ BEGIN

- 1 Hold the side fascia assembly flush with roof sheathing and front fascia trim (Fig. B).

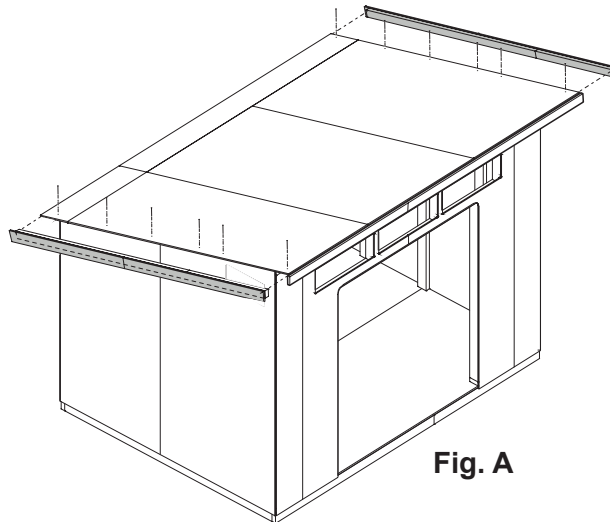

Fig. A

- 2 Install side fascia assembly underneath roof panels, flush with front fascia board. Secure with 2" screws through roof sheathing (Fig. C).

⚠ Ensure there is a 5-1/4" space as shown (Fig. C).

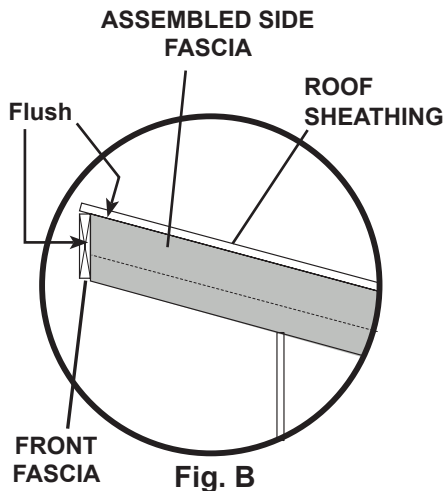

Fig. B

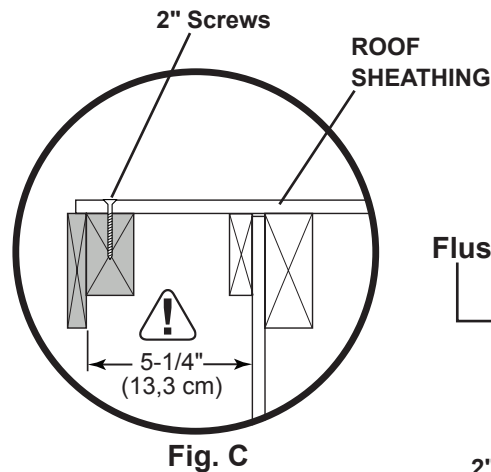

Fig. C

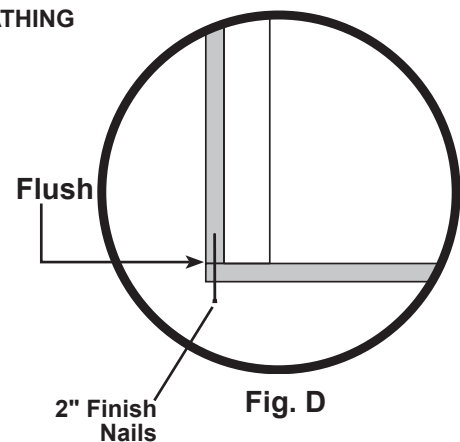

Fig. D

- 3 Secure front fascia to side fascia with (2) 2" finished nails (Fig. D).

Repeat steps on opposite side.



Your side fascia trim is installed.

REAR FASCIA TRIM

PARTS REQUIRED:

x1 **FS**
2 x 3 x 35-1/4" (5,1 x 7,6 x 89,5 cm)

x1 **BYA**
19/32 x 3-1/2 x 35-1/4" (1,5 x 8,8 x 89,5 cm)

x1 **PT**
2 x 3 x 96" (5,1 x 7,6 x 243,8 cm)

x1 **ZX**
19/32 x 3-1/2 x 96" (1,5 x 8,8 x 243,8 cm)

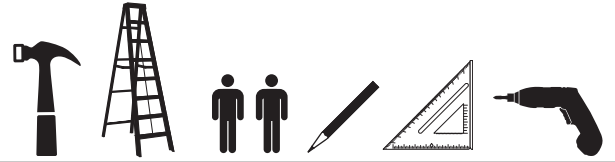
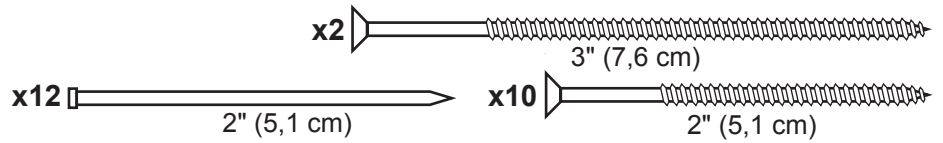

Install all trim with the primed side facing out.

✓ BEGIN

1 Install **PT** and **FS** flush to roof sheathing and to **ZT**. (Fig. B, Fig. C)

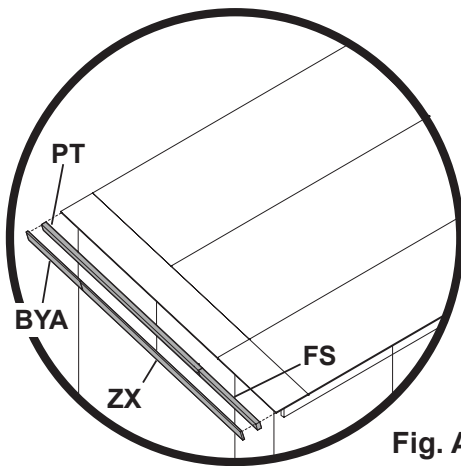

Fig. A

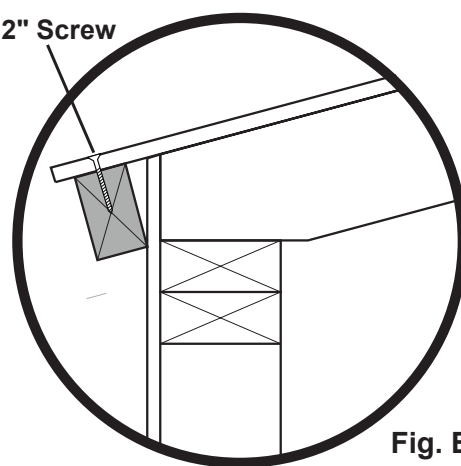

Fig. B

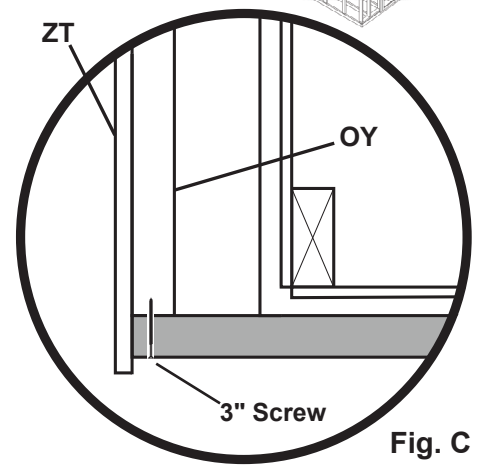

Fig. C

2 Secure **PT** and **FS** with 2" screws through roof sheathing, and with (1) 3" screw at **OY**, on both ends (Fig. B, Fig. C).

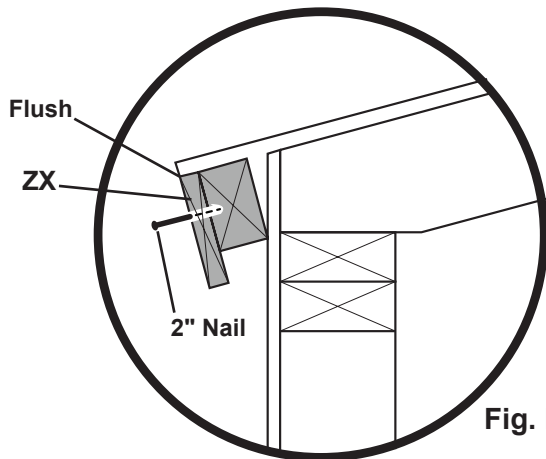

Fig. D

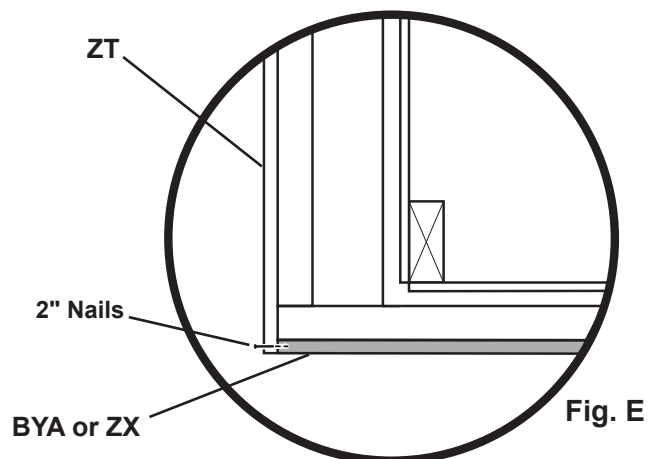

Fig. E

3 Secure **BYA** and **ZX** to **PT**. Secure **FS** to **ZT**. Secure parts with 2" nails (Figures A, D, E).



Your rear fascia trim is now installed.

SOFFIT

PARTS REQUIRED:

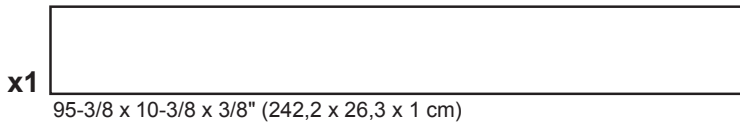
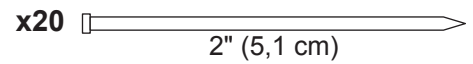
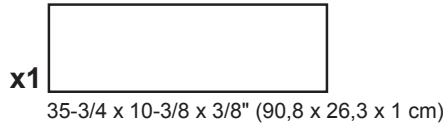

Install all trim with the primed side facing out.

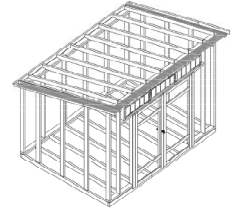
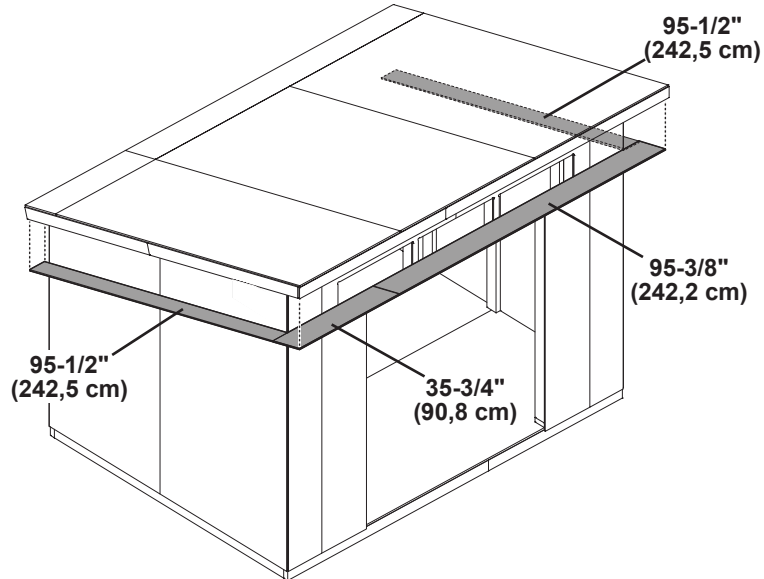

✓ **BEGIN**

1 Install 35-3/4" soffit board under **BRA**.
Secure with (6) 2" finishing nails (**Fig. A, B**).

2 Align 95-3/8" soffit board flush with 35-3/4".
Secure soffit board with (14) 2" finished nails underneath **BRA** (**Fig. D**).

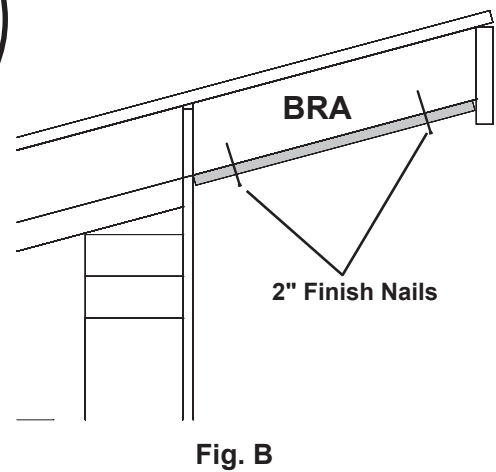
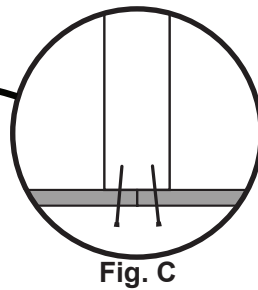
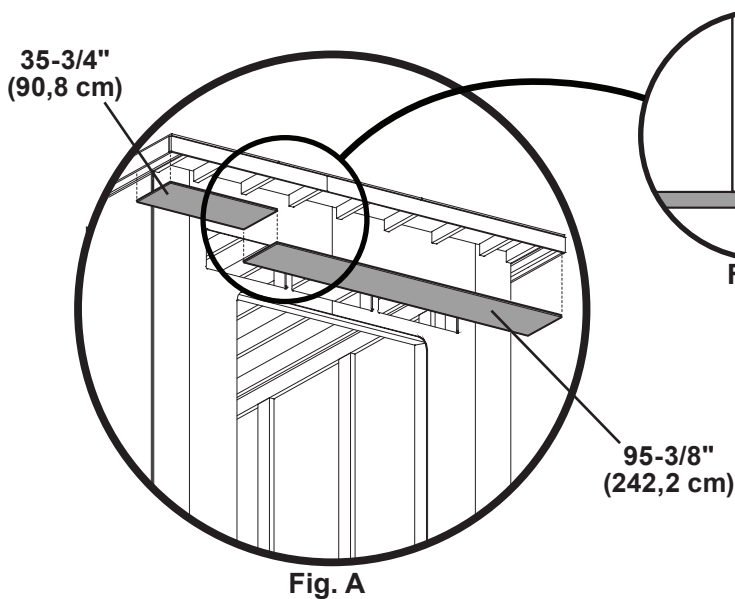

SOFFIT continued.....

PARTS REQUIRED:

x2 
95-1/2 x 5-1/4 x 3/8" (242,5 x 13,3 x 1 cm)

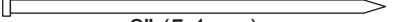
x28 
2" (5,1 cm)



- 3** Install 95-1/2" soffit board under fascia backer and side rake framing (Fig. C, D).
Secure with (14) 2" nails.

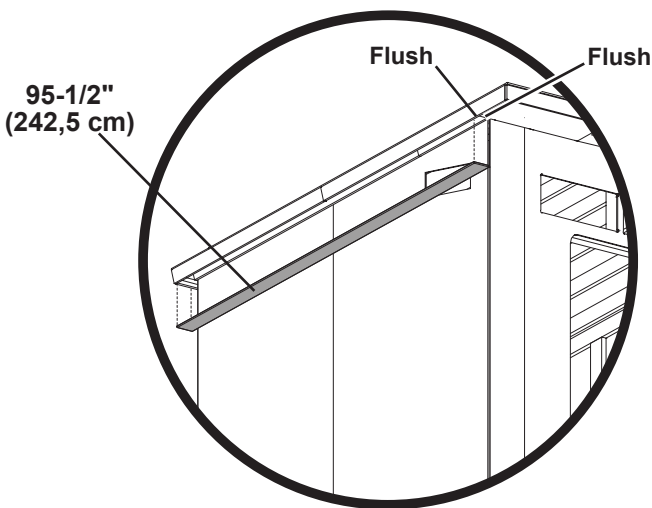
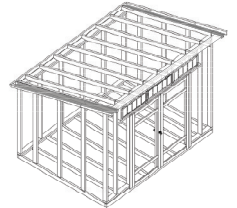

Fig. C

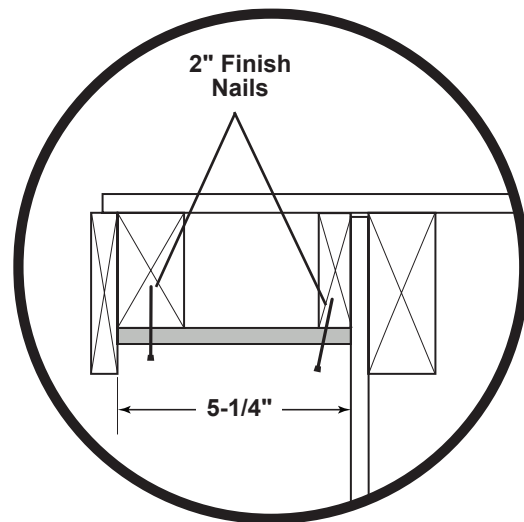

Fig. D

Repeat Step 3 on the opposite side.



Your soffit panels are now installed.

DOORS

PARTS REQUIRED:

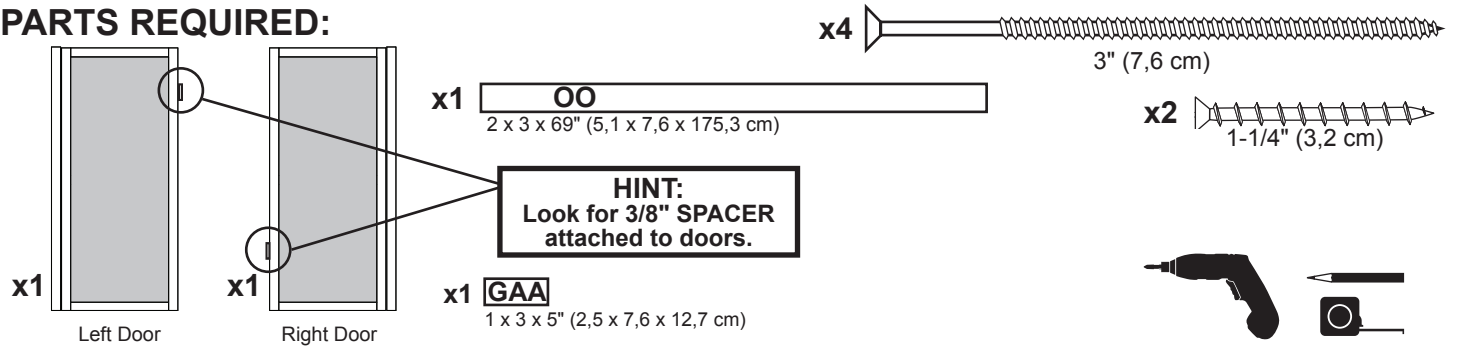

✓ BEGIN

- 1 Arrange parts as shown on flat surface. **!** 3/8" offset is to top.
Look for red (right) and green (left) on hinge board.
- 2 Secure temporary support **OO** with 3" screws in middle and at ends, as shown.
- 3 Secure temporary support **GAA** with (2) 1-1/4" screws.

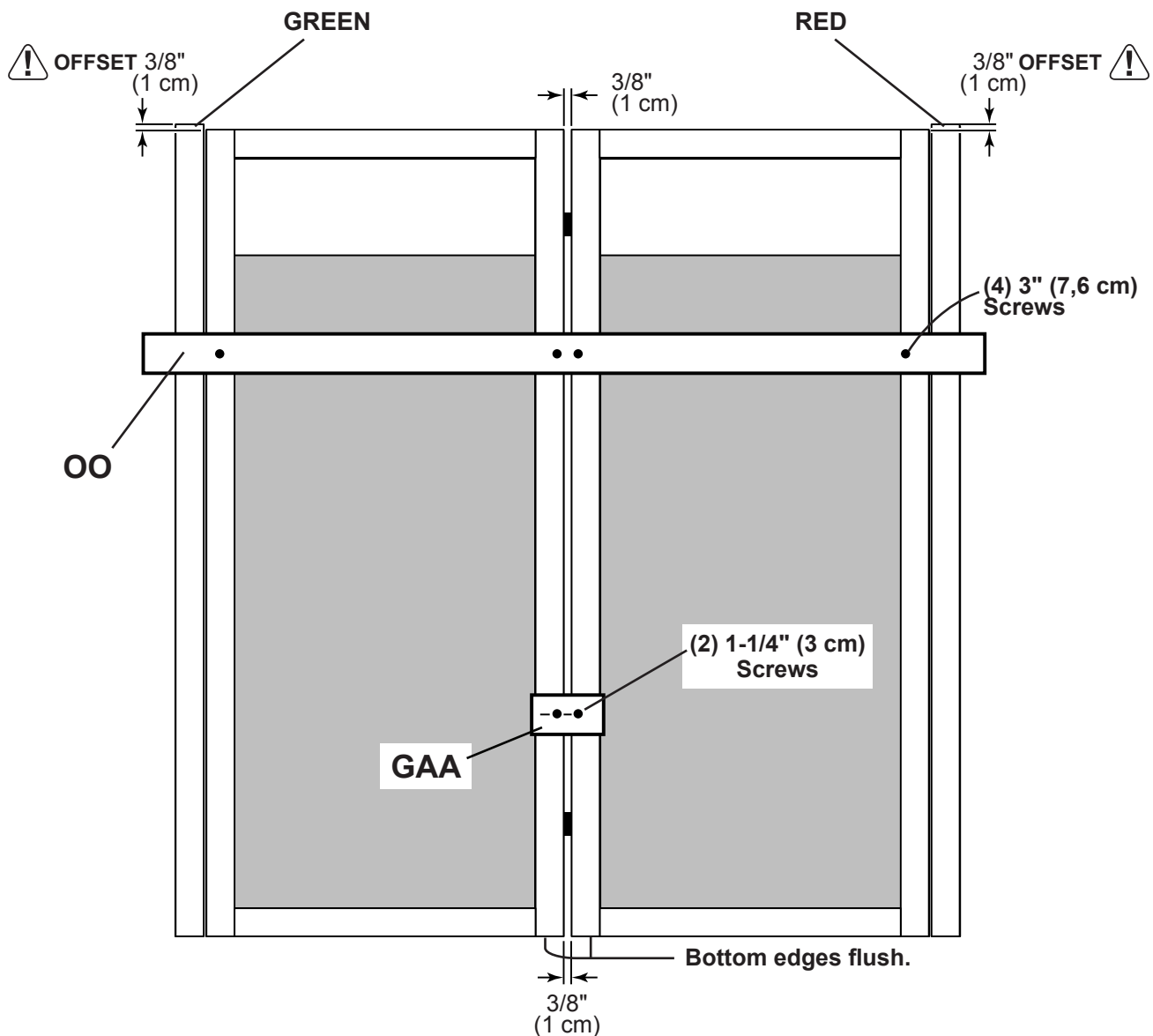
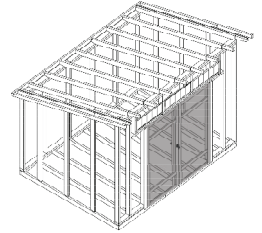

DOORS

PARTS REQUIRED:

x1 **OO** 
69" Door Stiffener (175,3 cm)

x13 
3" (7,6 cm)



- 4** Install temporary support **OO** flush under wall panels.
Secure with 3" screws (**Fig. A**).

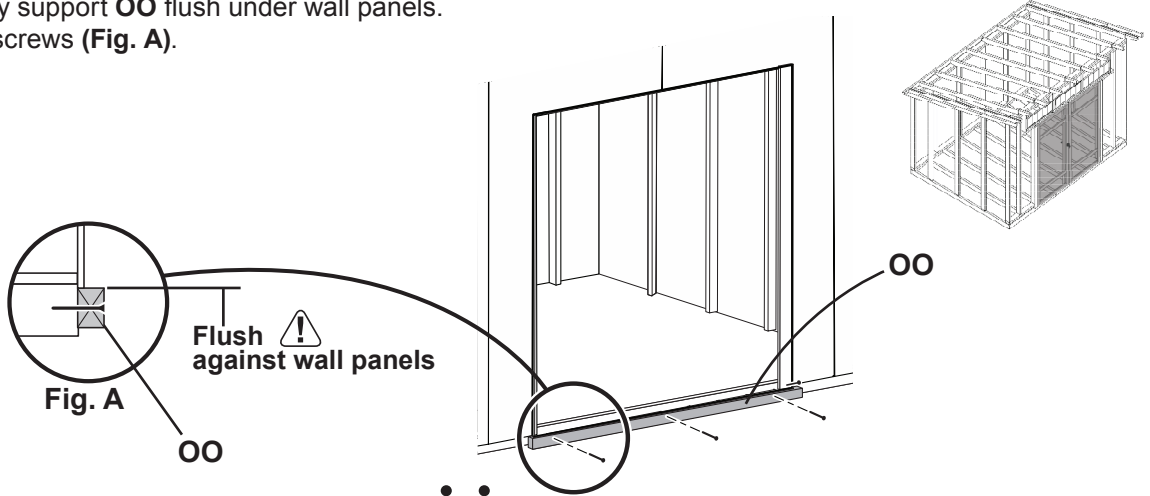

- 5** Center doors on panel seam as shown (**Fig. B**). 

 Check ledger board is still flush under panels.

- 6** Screw hinge boards into wall frame and floor with (10) 3" screws, as shown.

 Make sure screws go into framing and floor (**Fig. C, D**).

Remove temporary supports and check doors open properly.

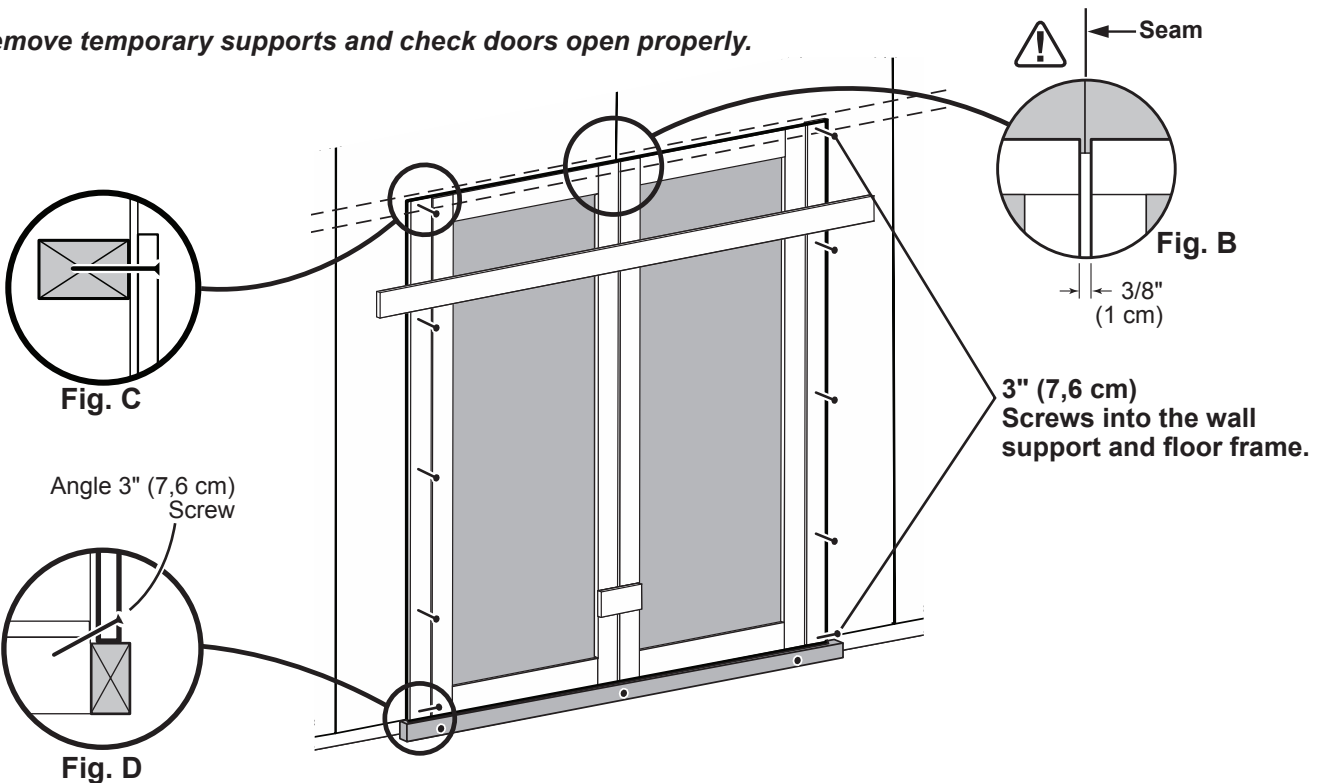

Your doors are now installed.

DOOR RAILS - OPTION 1

PARTS REQUIRED:

x4 **AH**
19/32 x 2-1/2 x 26-5/8" (1,5 x 6,3 x 67,6 cm)

x1 **EHT**
19/32" x 3-1/2" x 11-3/8"
(1,5 x 8,9 x 28,9 cm)

x44 
3/4" (1,9 cm)



See next page for door rails Option 2.

✓ **BEGIN**

1 Secure (2) horizontal door rails **AH** at measurements shown. Use **EHT** as a spacer. Secure door rails from inside with 3/4" screws (**Fig. A**).

2 Reinforce the door trim with 3/4" screws through door panel into trim (**Fig. A**). Locate screws as shown (**Fig. B**).

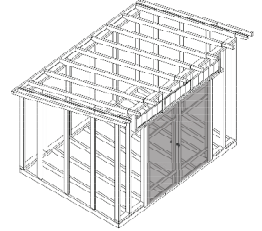

Repeat steps to install rails on other door.

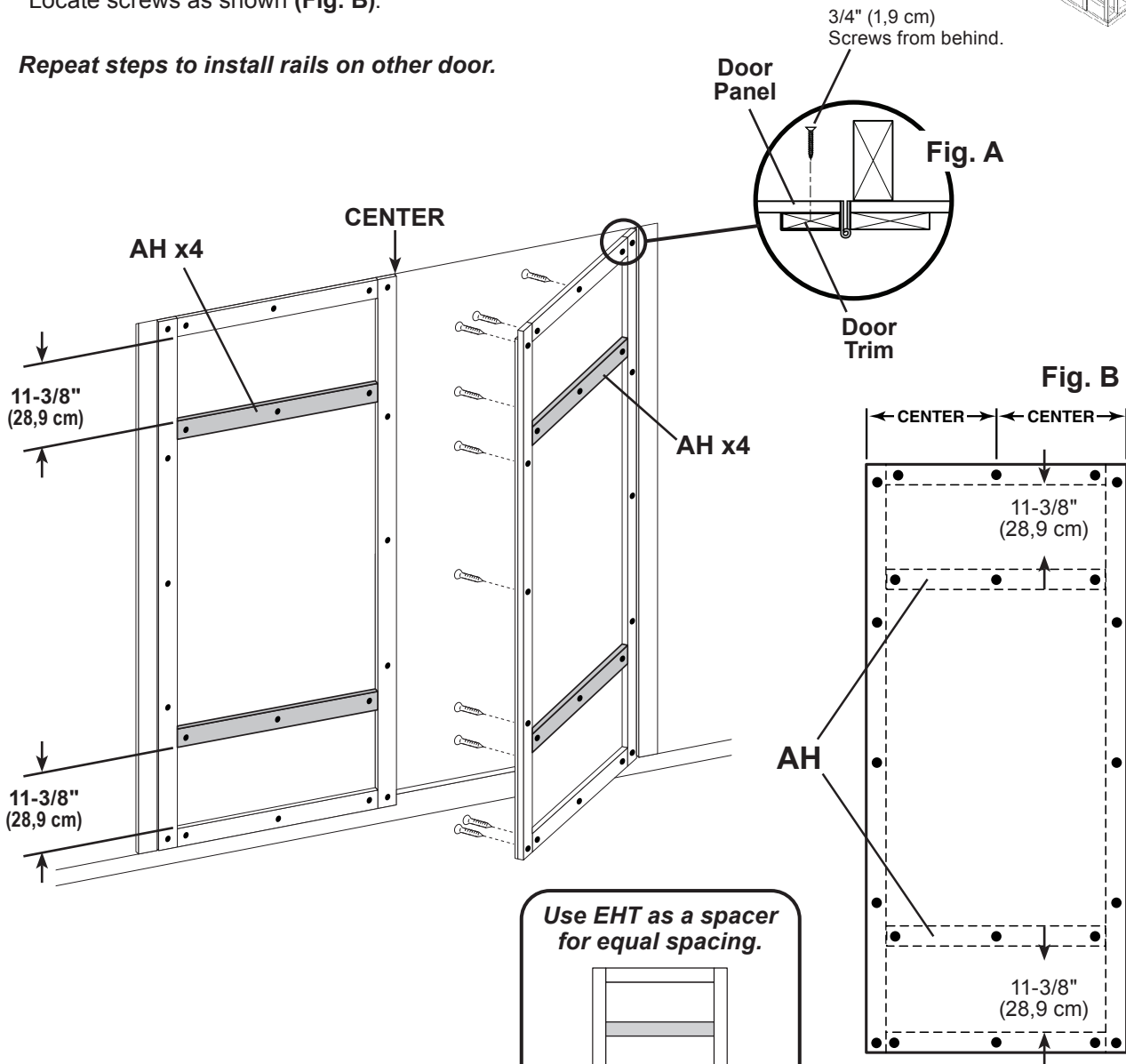

Use **EHT** as a spacer for equal spacing.

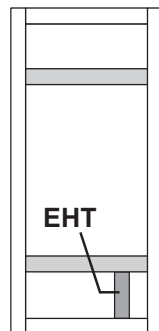

Your door and trim are now secured.

DOOR RAILS - OPTION 2

PARTS REQUIRED:

x8 **AH**
19/32 x 2-1/2 x 26-5/8" (1,5 x 6,3 x 67,6 cm)

x1 **EHT**
19/32" x 3-1/2" x 11-3/8"
(1,5 x 8,9 x 28,9 cm)

x56 
3/4" (1,9 cm)



✓ BEGIN

- 1 Secure (4) horizontal door rails **AH** at measurements shown. Use **EHT** as a spacer. Install bottom rail first. Secure door rails from inside with 3/4" screws (**Fig. A**).

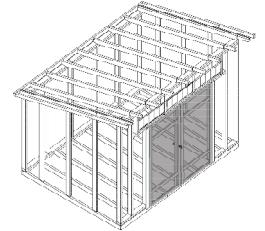

- 2 Reinforce the door trim with 3/4" screws through door panel into trim (**Fig. A**). Locate screws as shown (**Fig. B**).

Repeat steps to install rails on other door.

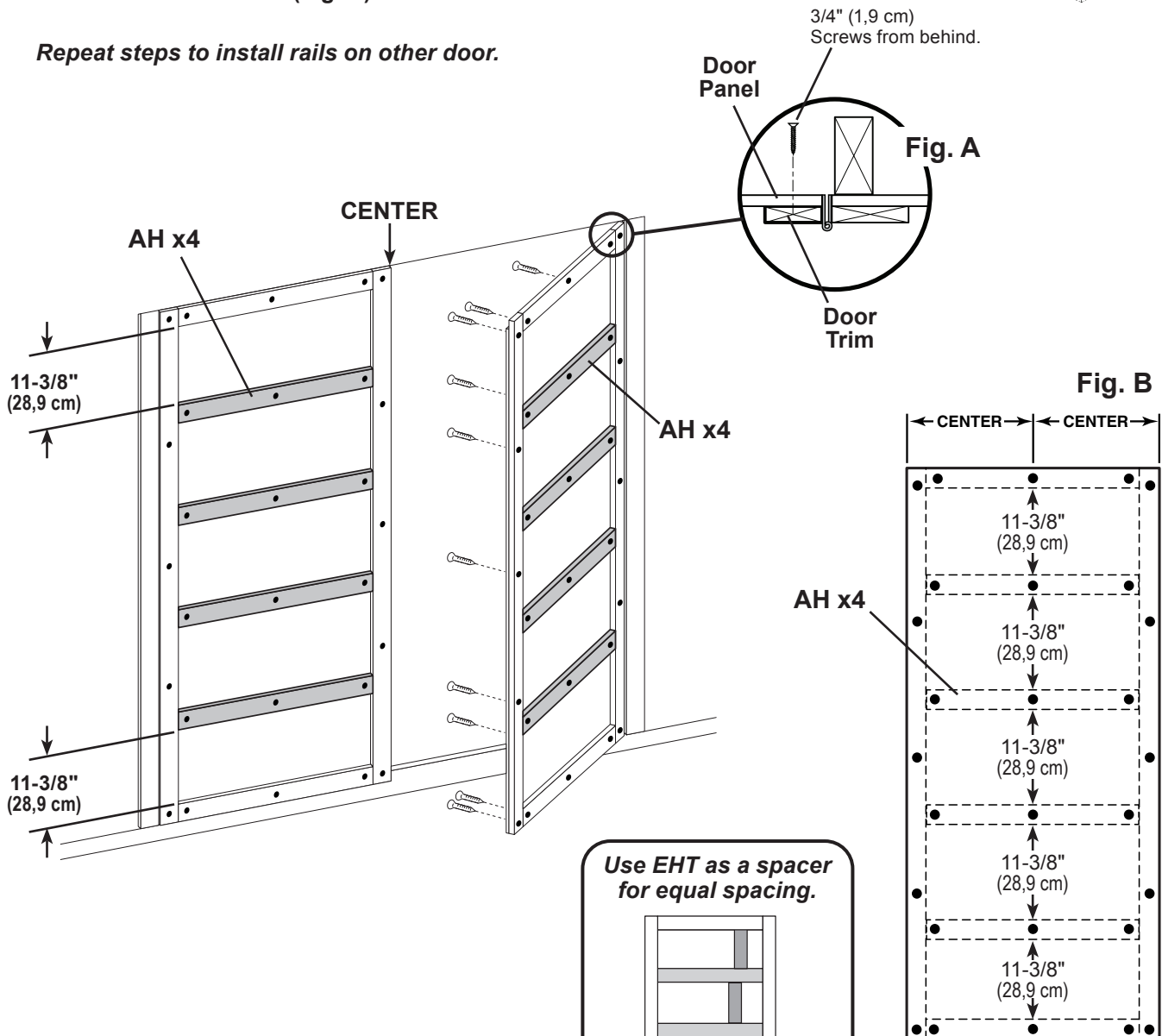





FINISH

Your door and trim are now secured.

DOOR WEATHERSTRIPPING

PARTS REQUIRED:

x2 
 69" Door Stiffener (175,3 cm)

x10  2" (5,1 cm)
   

✓ BEGIN

- 1 With left door closed, center a weatherstrip **OO** vertically on the left door in the door opening (Fig. A).
 OO will offset the left door 1" *OUT* past the door trim 1" (Fig. B).
 Secure **OO** with (5) 3" screws through outside trim into **OO** (Fig. B)
- 2 On the right door, center **OO** vertically in door opening (Fig. A).
 OO will offset the right door 1" *IN* from the door trim (Fig. C).
 Secure **OO** with (5) 3" screws through outside trim into **OO** (Fig. B)

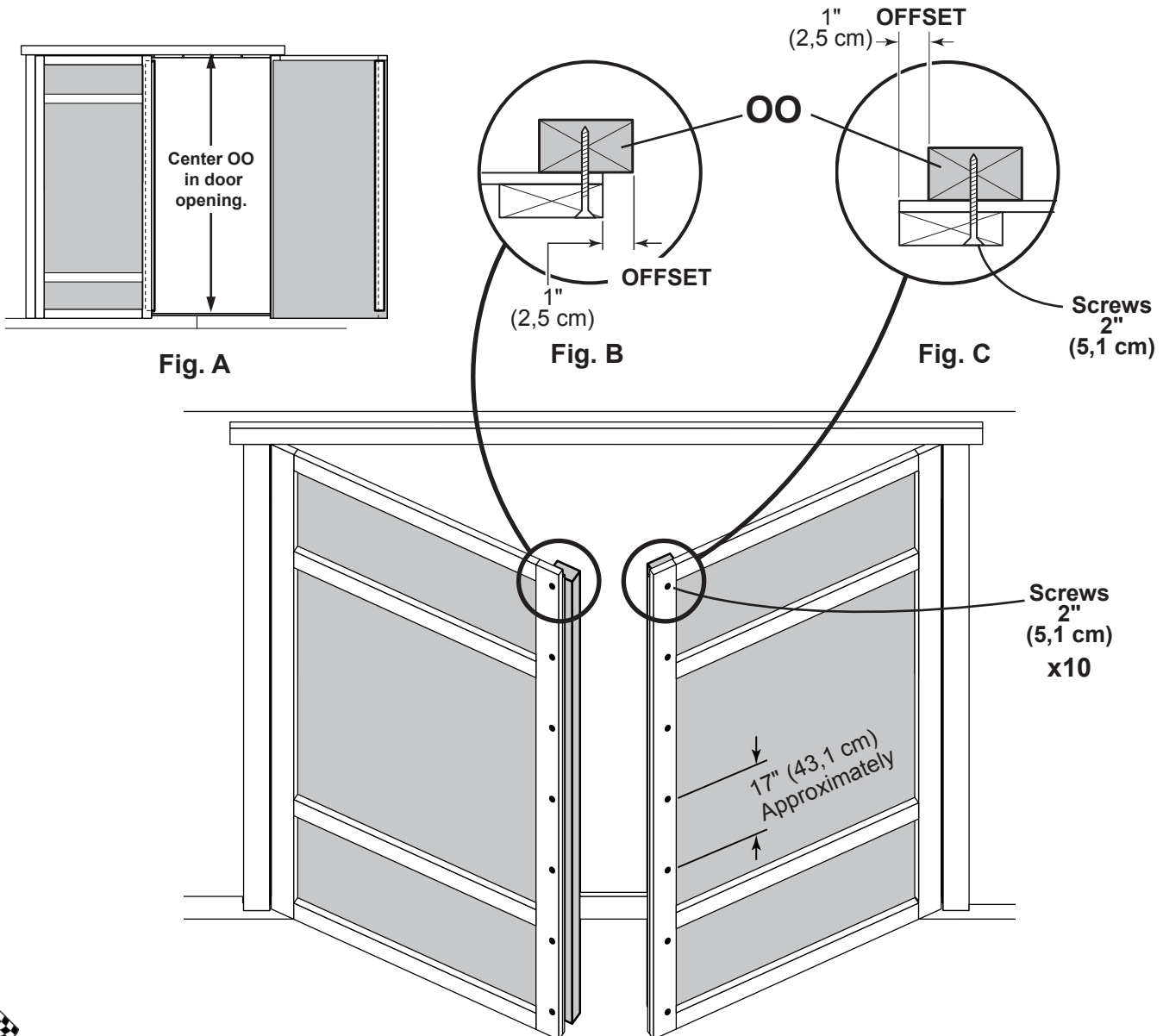
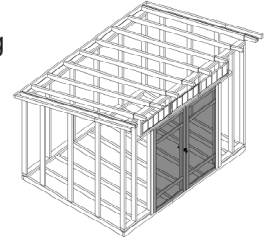

Your door weatherstripping is now installed.

DOOR HARDWARE

PARTS REQUIRED:

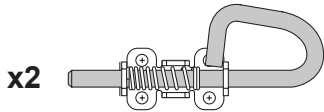

x8 
1" (2,5 cm)



✓ BEGIN

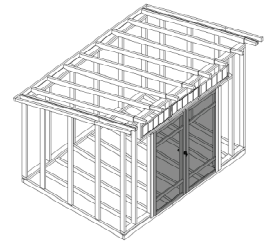

- 1 Install upper spring bolt onto **OO** in open position with bolt end 3/8" down from frame. Bolt is open when loop is contacting base (**Fig A**).

Mark and pre-drill holes for screws.

Secure bolt with screws supplied. Drill a 5/16" hole for bolt to extend into.

- 2 Install lower spring bolt onto **OO** in open position with bolt end 1/2" up from floor. Bolt is open when loop is contacting base (**Fig B**).

Mark and pre-drill holes for screws.

- 3 Install bolt with screws supplied and drill 5/16" hole for bolt to extend into.

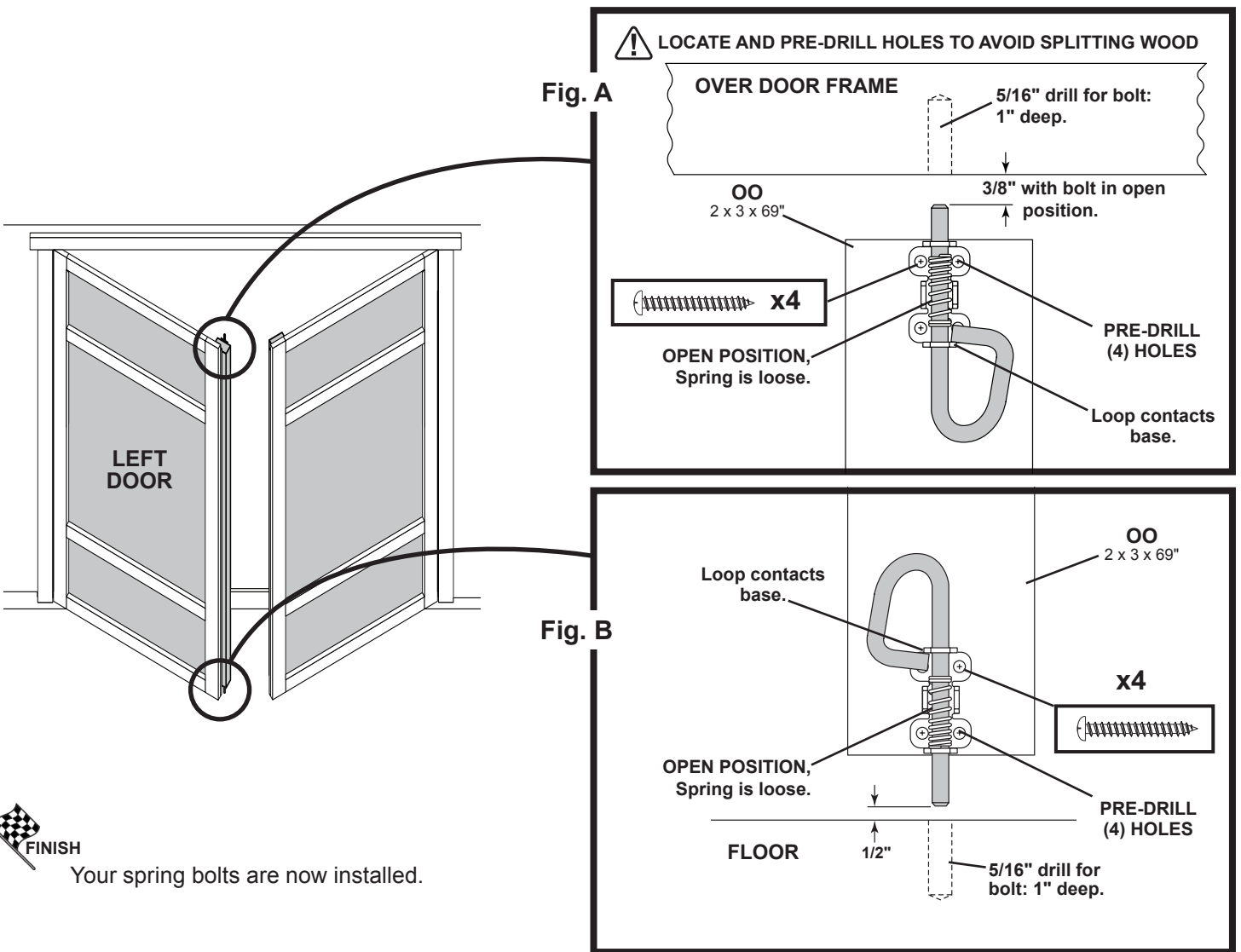

Your spring bolts are now installed.

DOOR HARDWARE

PARTS REQUIRED:

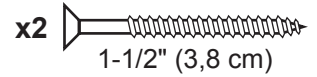
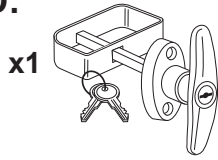

✓ BEGIN

- 1 Measure and mark location of hole on outside of right door (**Fig. A**).
Pre-drill hole with 1/4" drill.

Re-drill hole with 1/2" drill.

 Keep drilled hole square to trim to avoid breaking edge of 2x3".

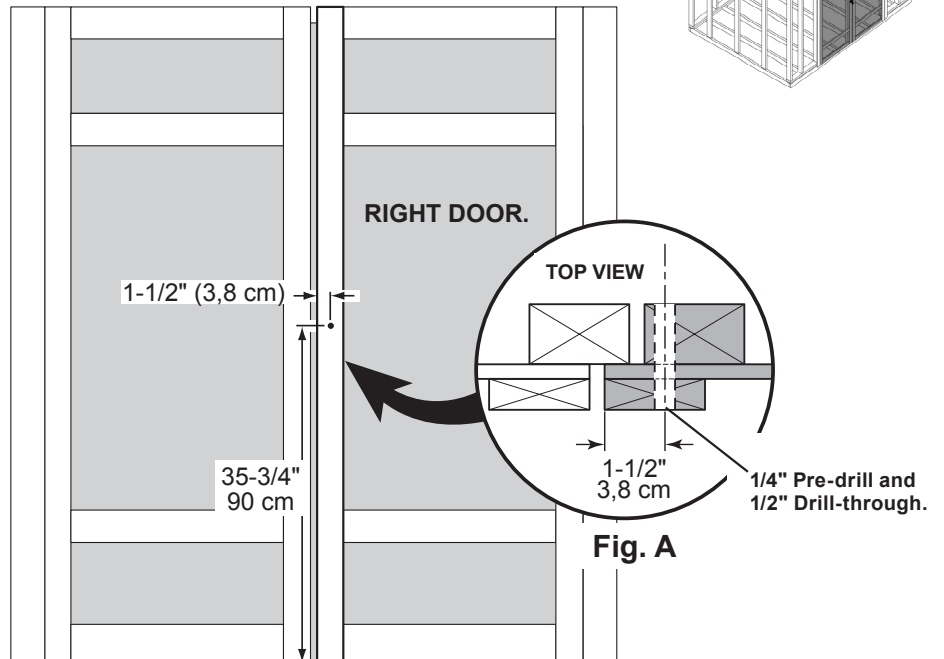
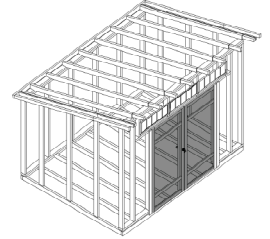

- 2 Insert handle in hole and secure with 1-1/2" screws.
Install inside handle and secure with set screw, as shown.

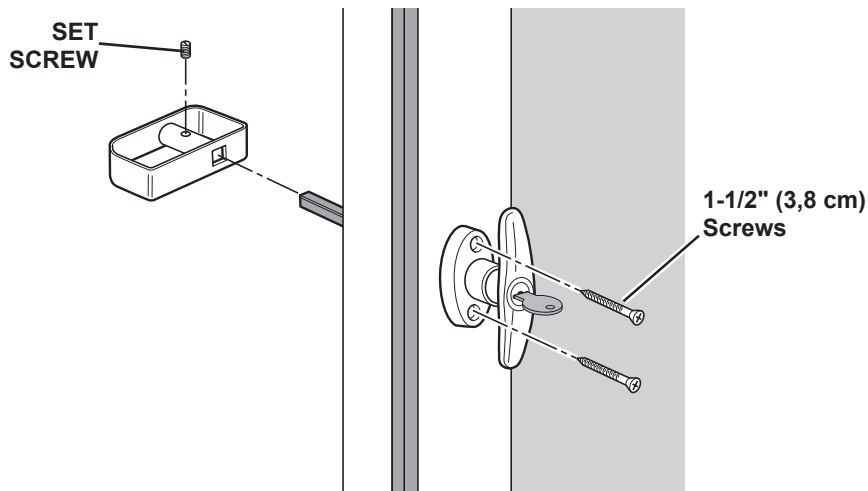

Your door handle is now installed.

WINDOWS

PARTS REQUIRED:

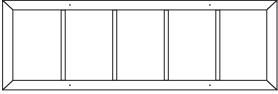
x3  9" x 27"
(22,8 x 68,5 cm)



x6 
3/4" (1,9 cm)

✓ **BEGIN**

1 Apply high quality exterior-grade caulk behind frame near edge before installing to seal window.

2 From outside of shed, install window in center of opening and level.
Secure with (2) screws at top of windows.

Do not fully tighten screws.

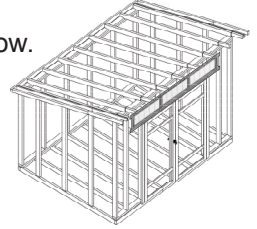

2 Screws per window

2 Screws per window

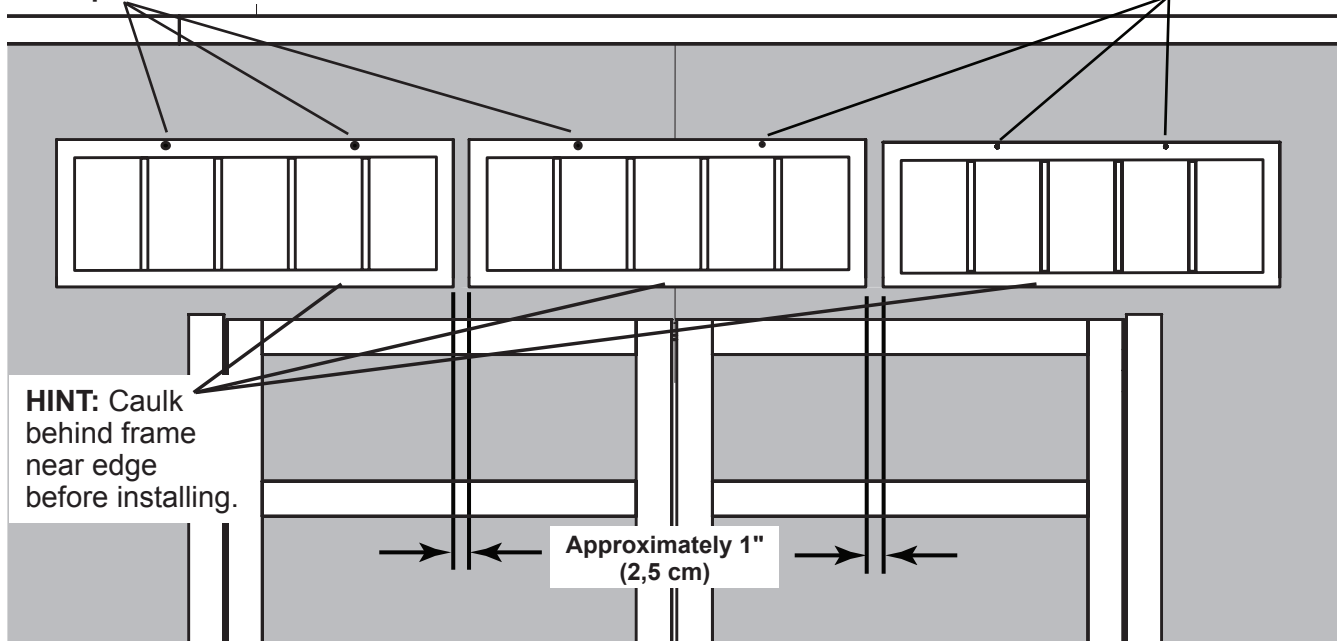



You must caulk around windows to validate warranty.

WINDOWS

PARTS REQUIRED:

x2 **BSA**
19/32 x 2-1/2 x 91" (1,5 x 6,3 x 231,1 cm)

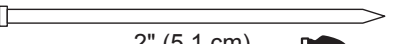
x4 **EY**
19/32 x 2-1/2 x 9" (1,5 x 6,4 x 22,9 cm)

x19  2" (5,1 cm) 

Install all trim with the primed side facing out.

3 Center **BSA** over door. Secure with (7) 2" finishing nails, as shown.

 **Do not nail into window flange.**

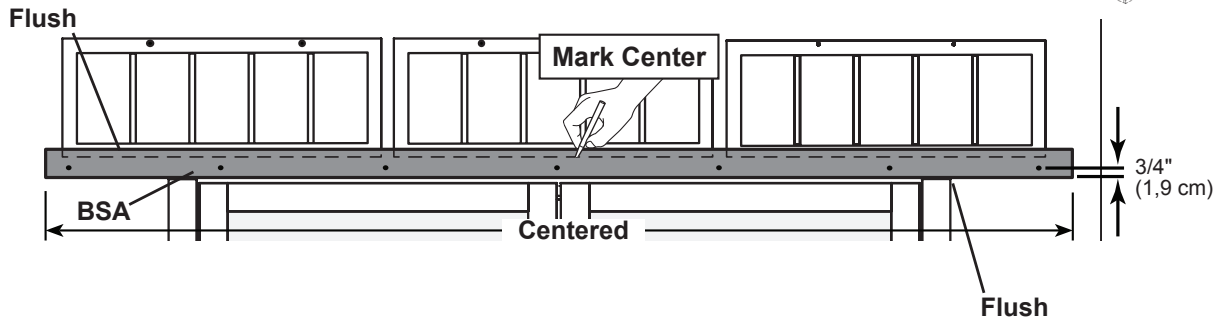
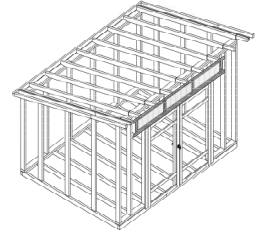

4 Install **EY** at ends and in between window frame, as shown. Secure with (8) 2" finishing nails. **Remove the 1-1/4" screws.**

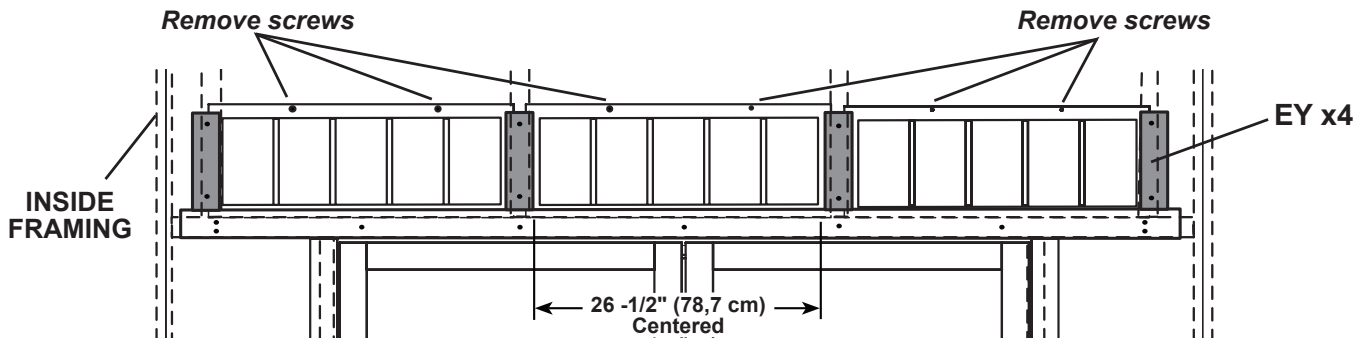

5 Install **BSA** centered on window frame, as shown. Secure with (4) 2" finishing nails.

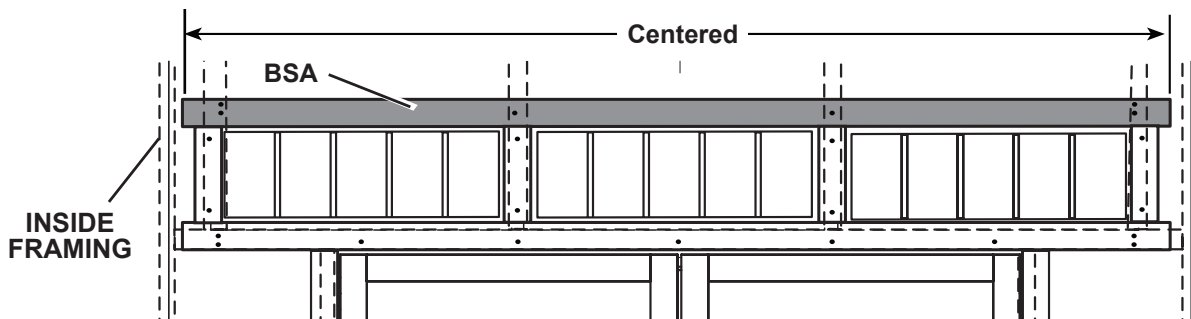

WINDOWS

PARTS REQUIRED:

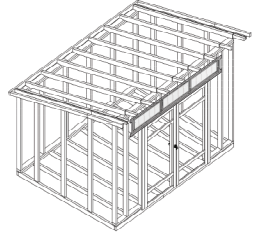

6 Working inside, secure trim with (12) 3/4" screws, as shown.

 **Do not screw into window flange.**

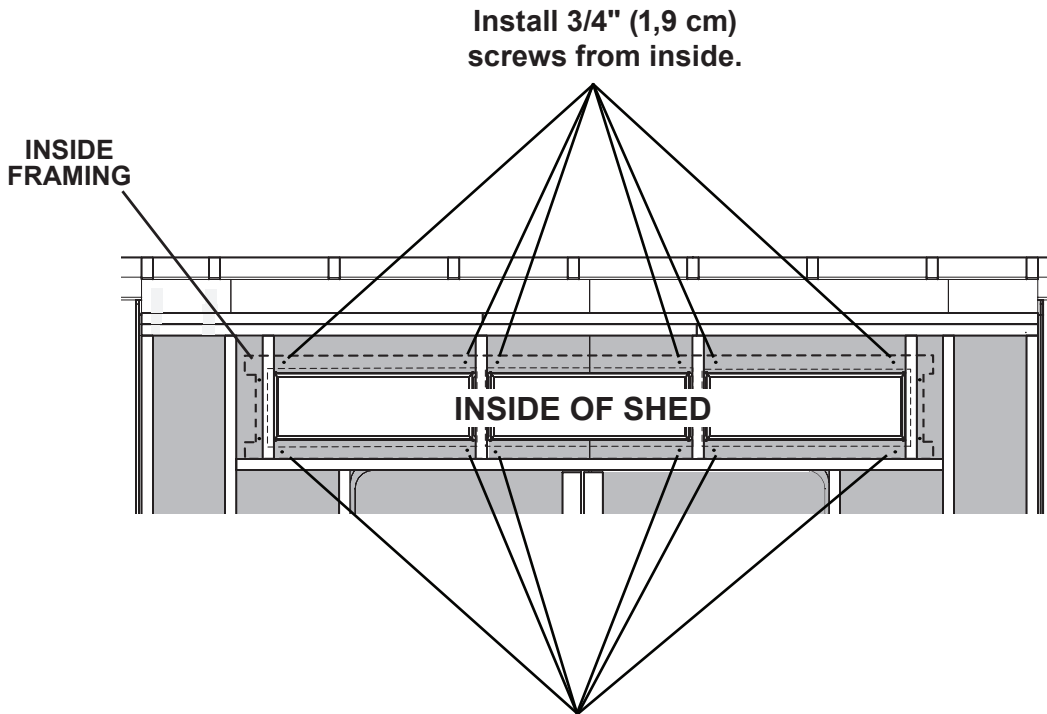

Install 3/4" (1,9 cm) screws from inside.

You must caulk completely around window frame and all exposed door panel edges and trim to validate your warranty. Use a paintable exterior rated caulk.

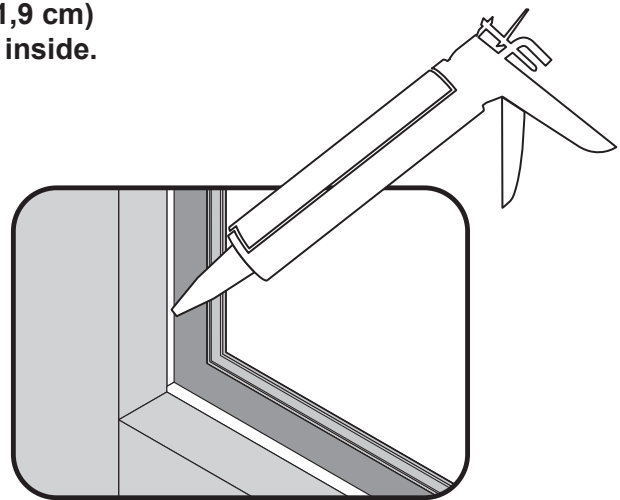

FRONT SIDE VIEW



Your windows are now installed.

BACK CORNER TRIM

PARTS REQUIRED:

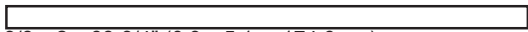
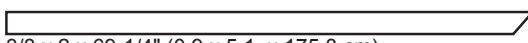
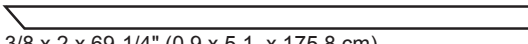
- x2  3/8 x 2 x 68-3/4" (0,9 x 5,1 x 174,6 cm)
- x1  3/8 x 2 x 69-1/4" (0,9 x 5,1 x 175,8 cm)
- x1  3/8 x 2 x 69-1/4" (0,9 x 5,1 x 175,8 cm)

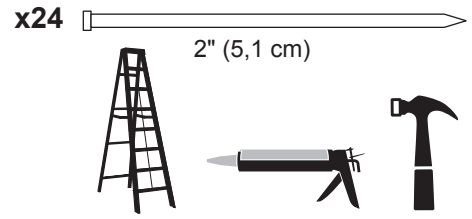

Install all trim with the primed side facing out.

✓ BEGIN

- 1 Place 68-3/4" back corner trim flush to bottom of back soffit board (Fig. A, B, F) and flush with side panel along the length (Fig. A).
Secure with (6) 2" finishing nails into corner wall framing (Fig. A, C).
Space nails equally (Fig. C).

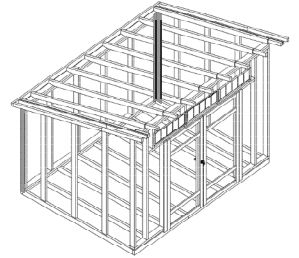

- 2 Install 69-1/4" back side corner trim angled end up (Fig. E), flush up under side soffit panel and flush with back corner trim along the length (Fig. E).
Secure trim with (6) 2" finishing nails into corner wall stud (Fig. D, C).
Space nails equally (Fig. C).

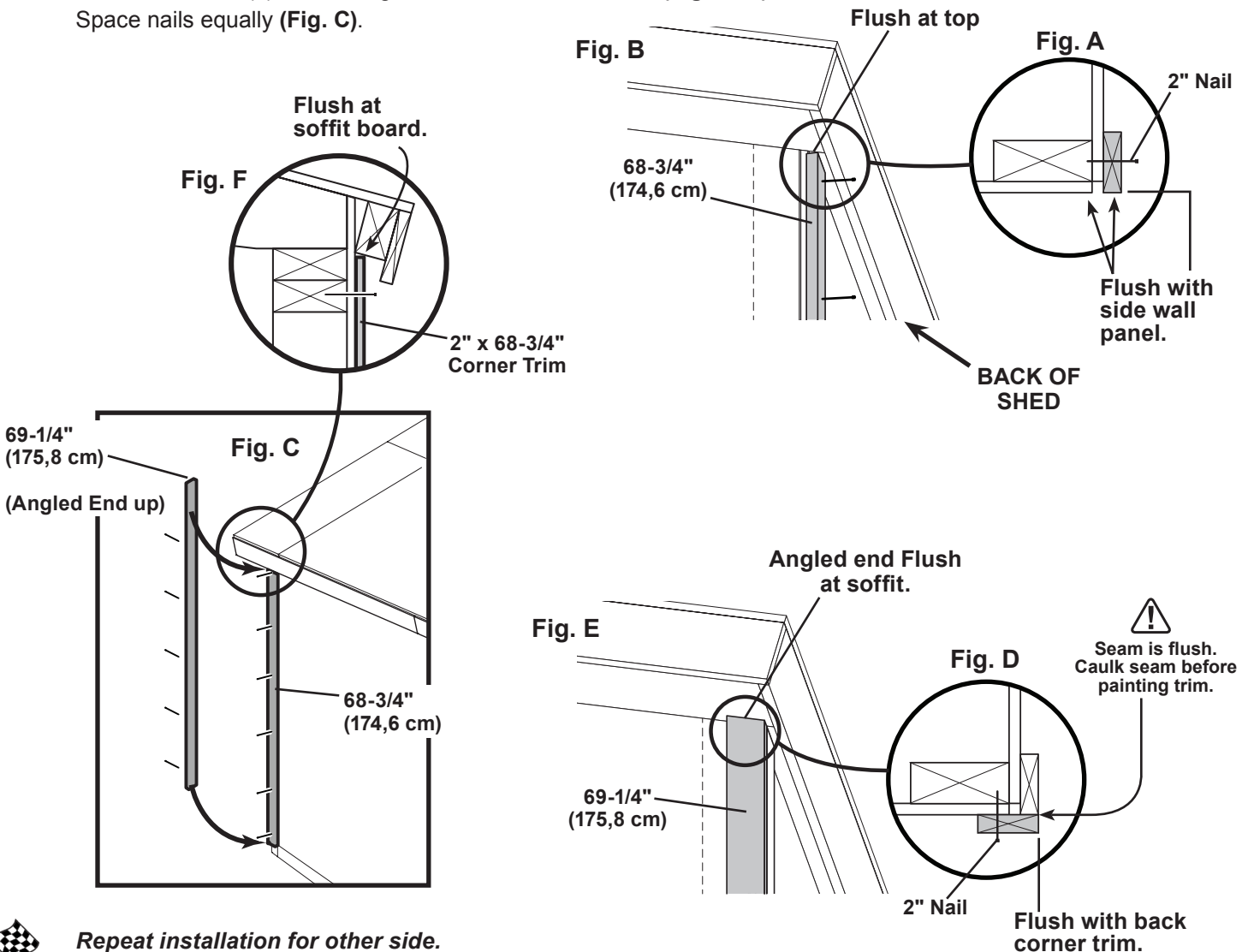

Repeat installation for other side.

FINISH

Your back corner trim is now installed.

FRONT FRIEZE TRIM

PARTS REQUIRED:

x1 
3/8 x 2 x 25-3/8" (0,9 x 5,1 x 64,4 cm)

x1 
3/8 x 2 x 96" (0,9 x 5,1 x 243,8 cm)

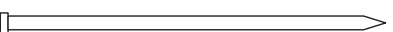
x12 
2" (5,1 cm)



✓ **BEGIN**

- 1 Install **25-3/8"** and **96"** front horizontal frieze boards. Leave 3/8" (9,5 mm) overhang on both ends (**Fig. B**). Secure with 2" finishing nails as shown (**Fig. A**).

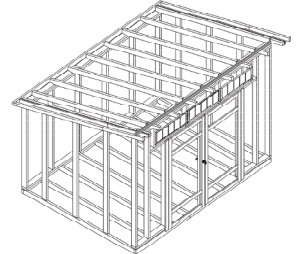

Fig. B

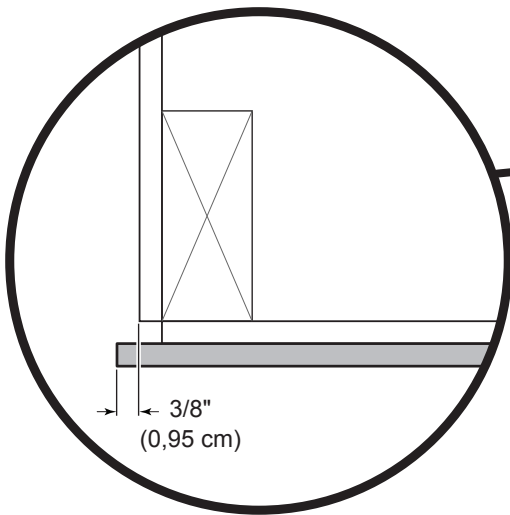
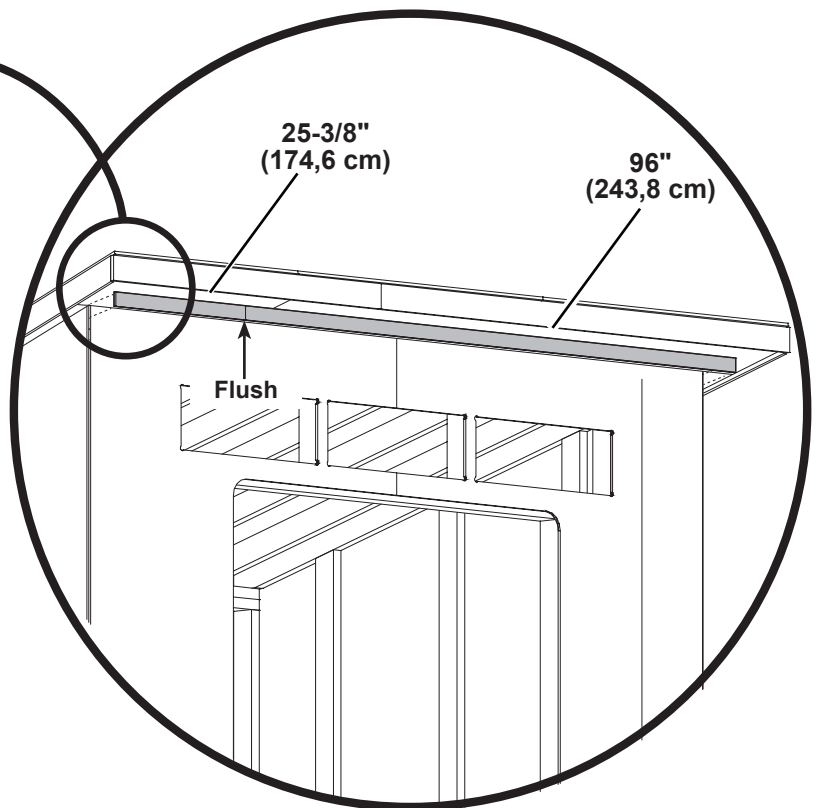

Fig. A





FINISH

Your front frieze trim is now installed.

FRONT CORNER TRIM

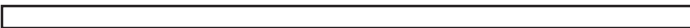
PARTS REQUIRED:

x2 
3/8 x 2 x 91-1/4" (0,9 x 5,1 x 231,7 cm)

x12 
2" (5,1 cm)



Install all trim with the primed side facing out.

✓ **BEGIN**

- 1** Install both vertical **91-1/4"** front corner trim on both sides, flush to bottom edge of previously installed horizontal frieze trim. Secure with (6) 2" finishing nails per trim (**Figures A, B, C**).

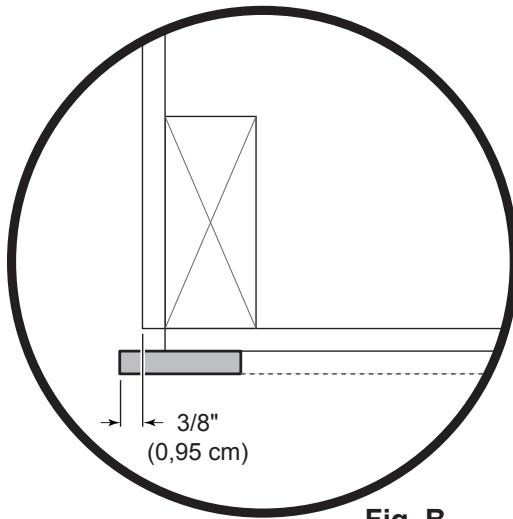
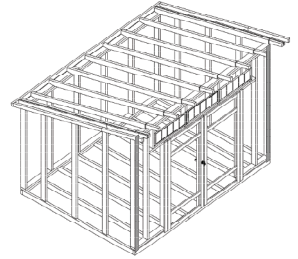

Fig. B

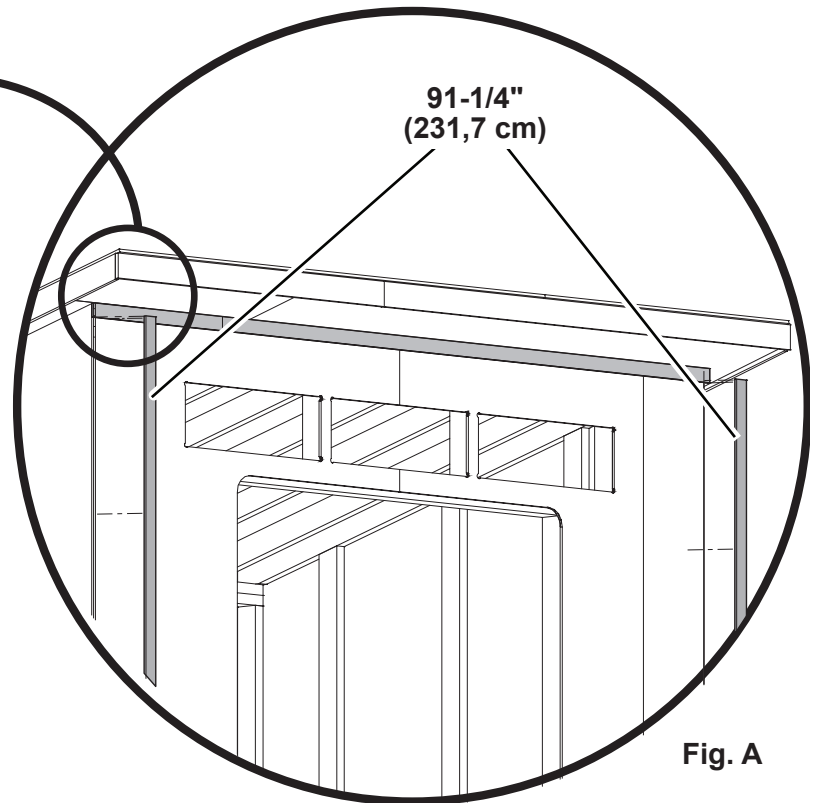

Fig. A

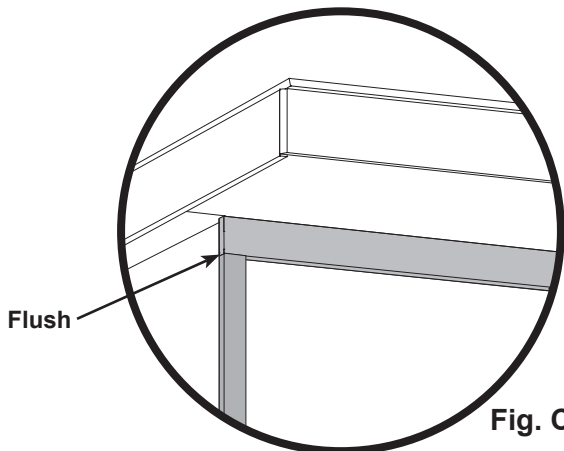

Fig. C





FINISH

Your front corner trim boards are now installed.

FRONT SIDE TRIM

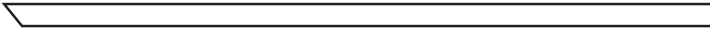
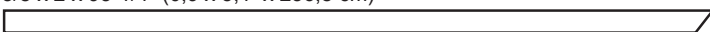
PARTS REQUIRED:

- x1 
3/8 x 2 x 93-1/4" (0,9 x 5,1 x 236,8 cm)
- x1 
3/8 x 2 x 93-1/4" (0,9 x 5,1 x 236,8 cm)

x12  2" (5,1 cm)



Install all trim with the primed side facing out.

✓ **BEGIN**

- 1** Install **93-1/4"** front side corner trims on both sides flush with front frieze trim. Secure trim to side wall with (6) 2" finishing nails (**Figures A, B, C**).

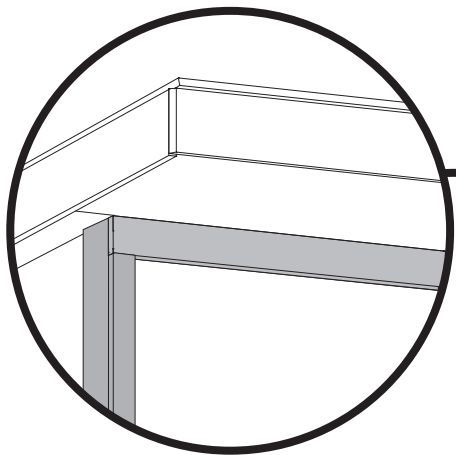
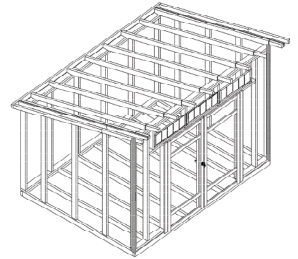

Fig. B

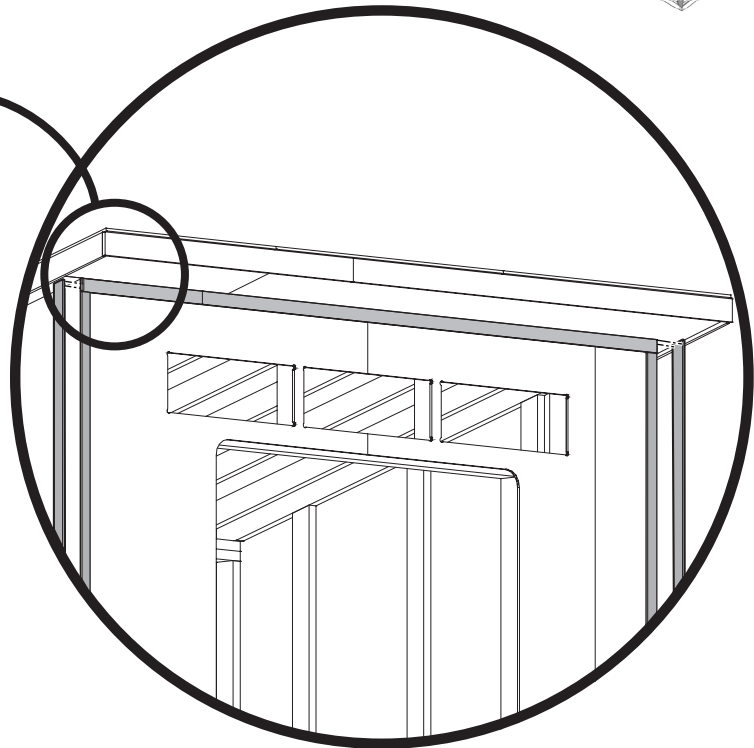
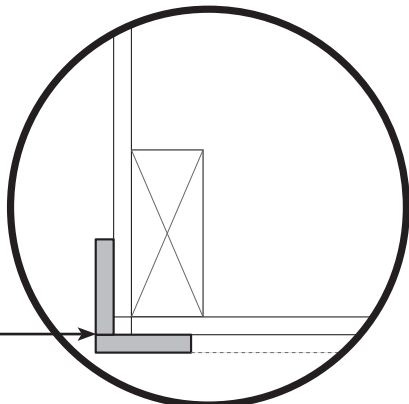

Fig. A



Flush →

Fig. C





FINISH

Your front side trim boards are now installed.

VENTS

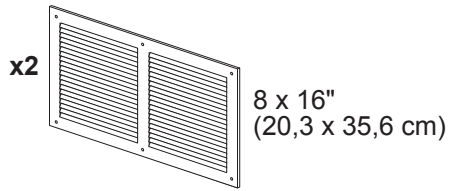
PARTS REQUIRED:



x12 
1/2" (1,3 cm)

✓ **BEGIN**

1 Locate and mark for two vents in side walls, as shown; (1) at top and (1) at bottom.

Cut out marked openings.

Caulk behind vent flanges.

2 Secure with 1/2" screws.

 **FINISH**

Your vents are now installed.

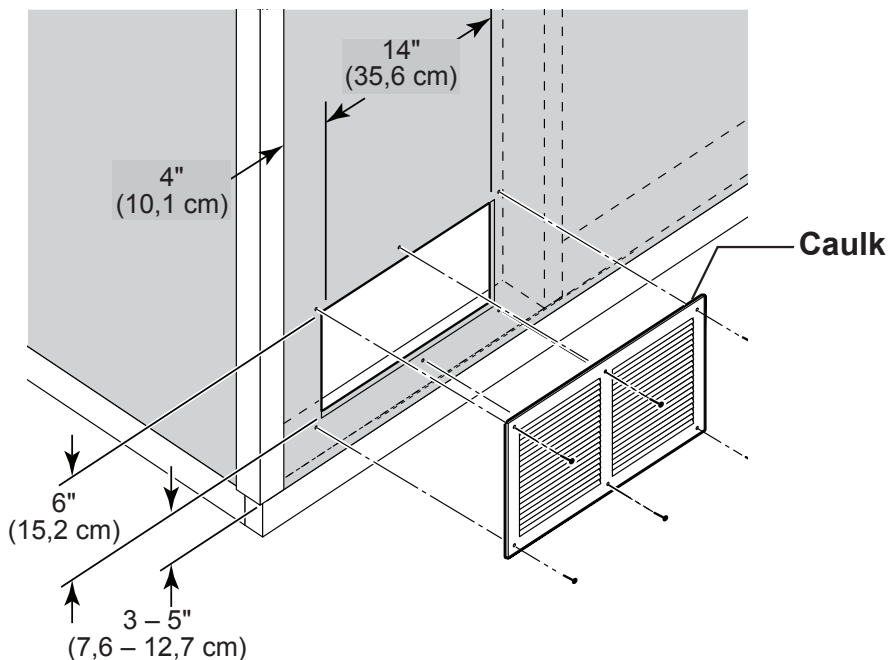
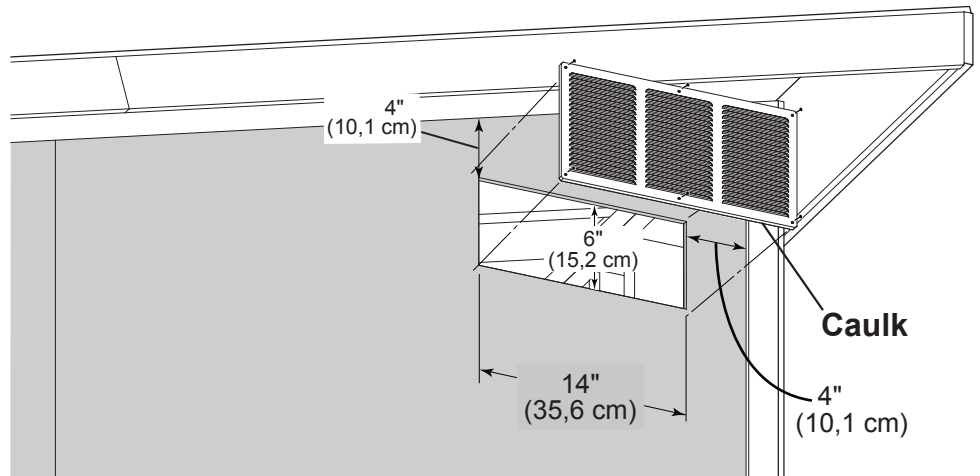
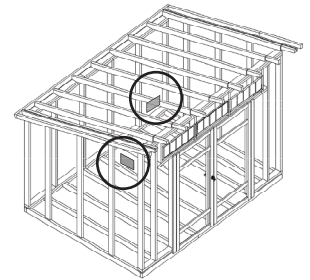

PAINT & CAULK

- NOT INCLUDED -

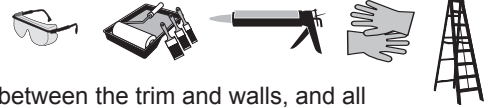

- Use acrylic latex caulk that is paintable. Caulk at all horizontal and vertical seams, between the trim and walls, and all around the door trim.
- Use a high quality exterior acrylic latex paint. When painting your building, there are a few key areas that can be easily overlooked that must be painted:
 - Bottom edge of all siding and trim
 - Inside of doors and all 4 edges

Note:

Prime all un-primed exterior wood before painting.
(Follow directions provided by manufacturer.)

ROOF FELT

- NOT INCLUDED -

- Install felt flush to all roof edges overlapping 3". Use minimal amount of roofing nails to hold in place.

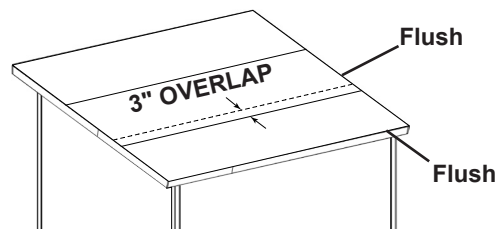

 You must install roof felt to validate warranty.

DRIP EDGE

- NOT INCLUDED -



- Install drip edge over roof felt on side of shed and under roof felt on back side (Fig. A).
- Do not use nails on side of drip edge that hangs over side of building.
- Only nail top of drip edge as shown.

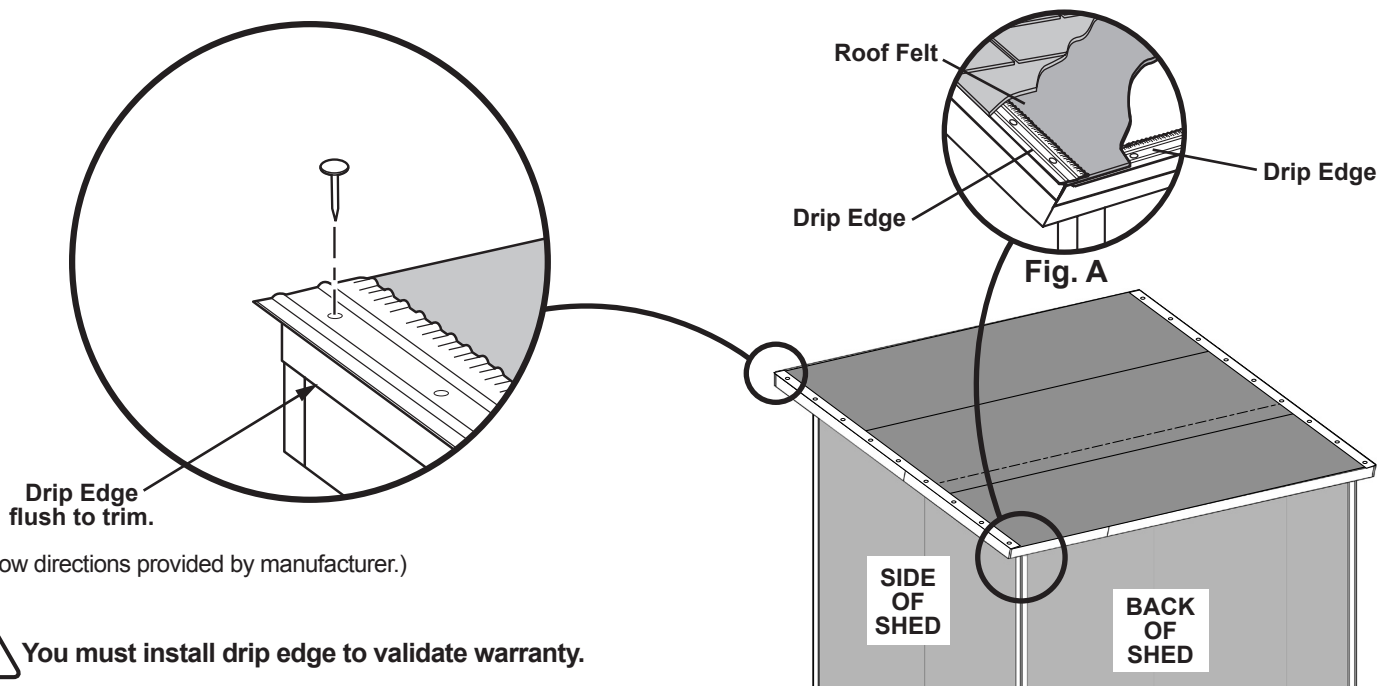

(Follow directions provided by manufacturer.)

 You must install drip edge to validate warranty.

SHINGLES

- NOT INCLUDED -



- Follow directions provided by manufacturer and these instructions.

! Familiarize yourself with a 3-Tab Shingle.

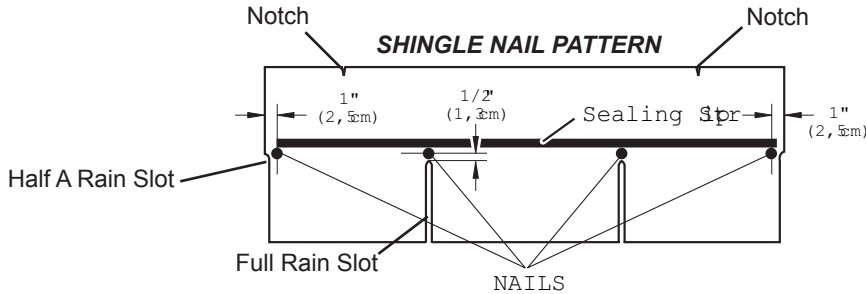

! NEVER DRIVE FASTENERS INTO OR ABOVE SEALING STRIPS.

✓ BEGIN
1

Install first starter row upside down, color up and flush to drip edge at bottom of roof panel. Use (4) nails per shingle. Starter row must be straight and level all the way across with lower edge of roof deck.

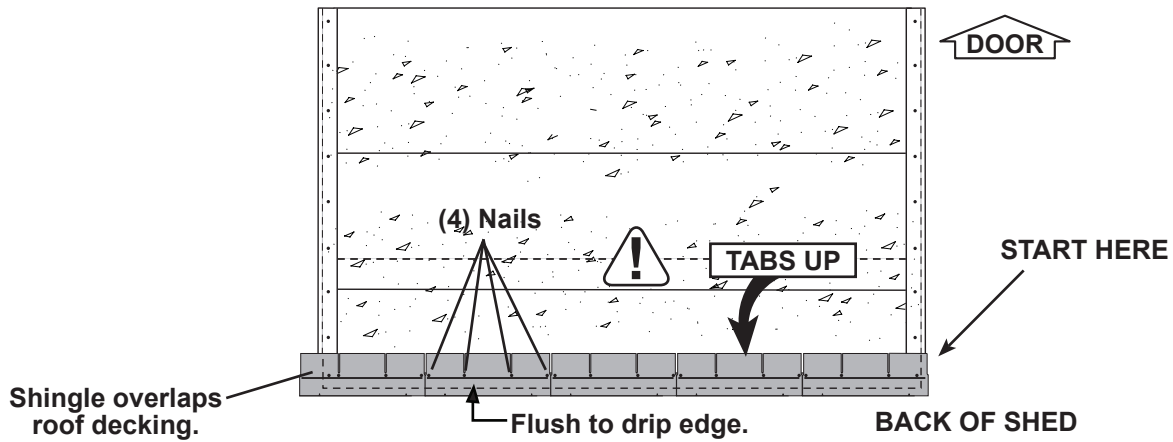

2 Begin where indicated on image below, install first row of shingles with notch flush with drip edge.

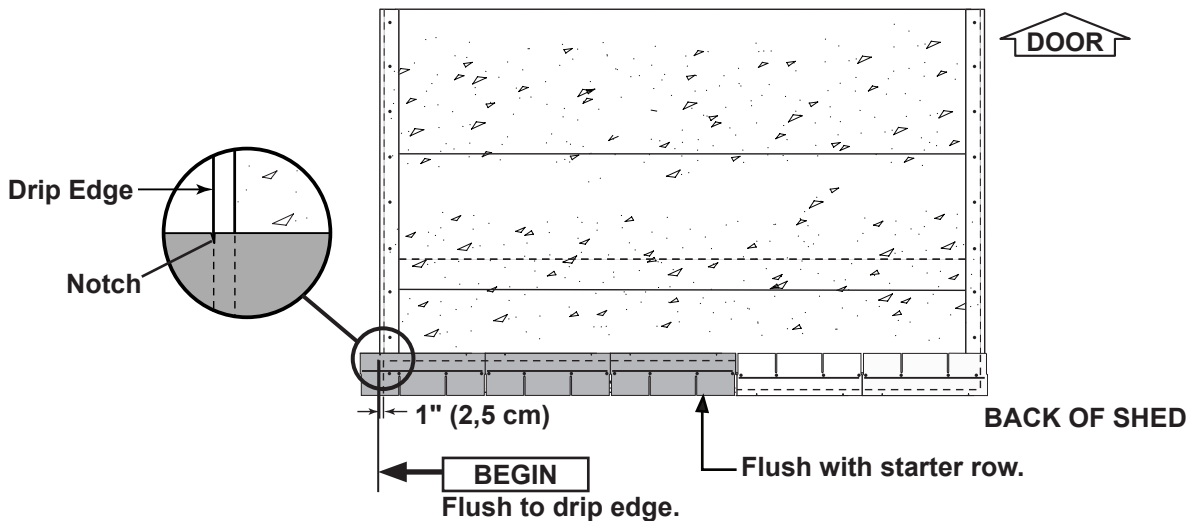

SHINGLES

continued...

- 3** Install second row of shingles flush at top of first row's rain slots. Ensure flush to drip edge at front side, stagger each row.

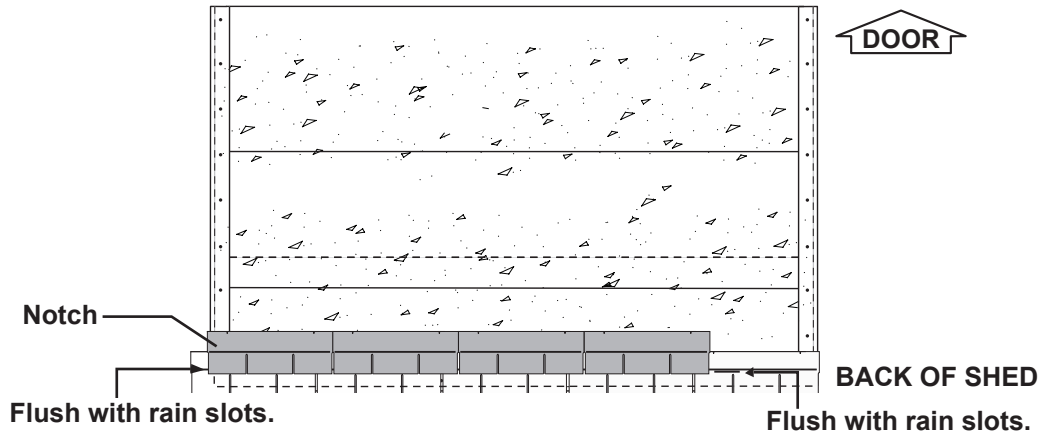

- 4** Continue installing rows of shingles by staggering at front.

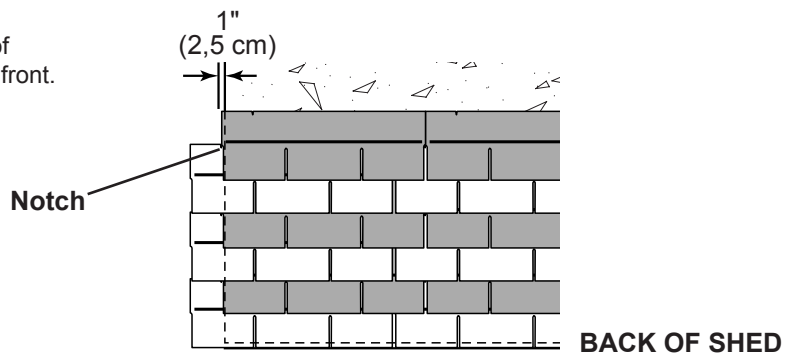

- 5** Continue installing rows of shingles to the front of the shed. At the front edge of the shed make sure there is a maximum of 5" or less to the rain slot, as shown below. If shingles overlap at front roof edge cut to roof edge with a utility knife.

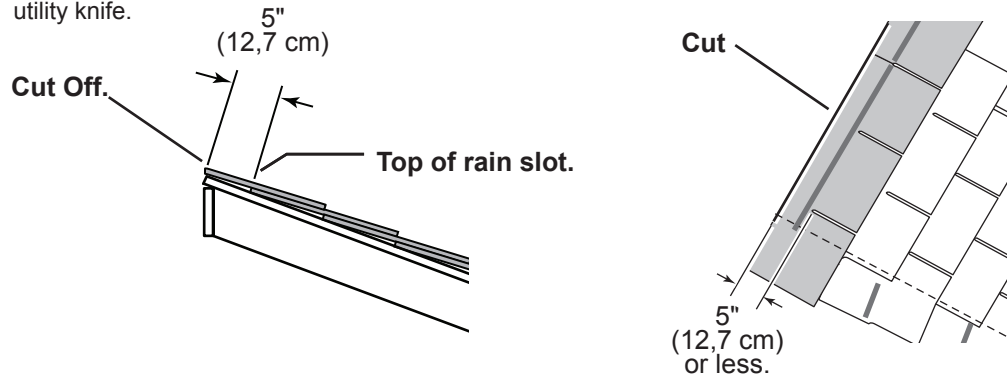

- !** • If more than 5" to rain slot you must install another row of shingles.

- 6** Using your shingle hooked blade carefully cut shingles along chalk line.

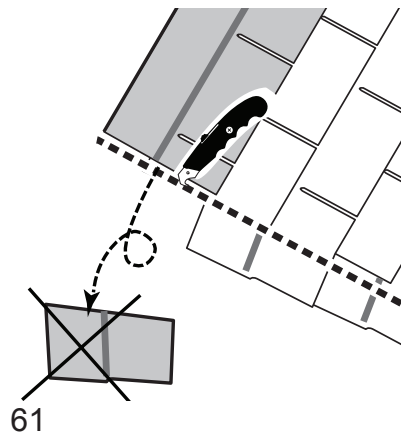

SHINGLES - DRIP EDGE

- 7 Install drip edge over top shingle row with 1" overhang over roof edge.

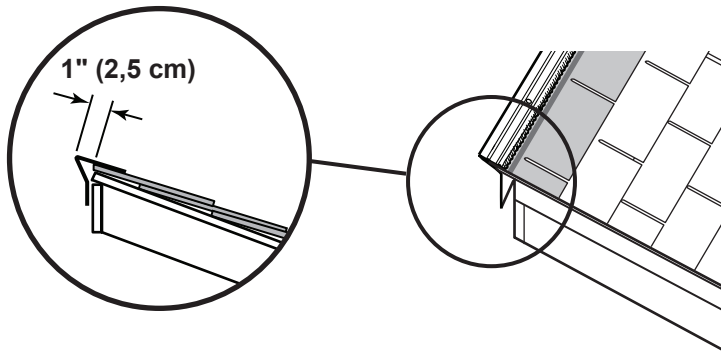

- 8 Using your shingle hooked blade carefully cut shingles on a flat surface along the rain slots, using a chalk line for reference.

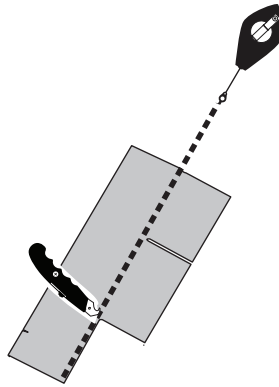

- 9 Align remaining shingles with edge of the front drip edge.

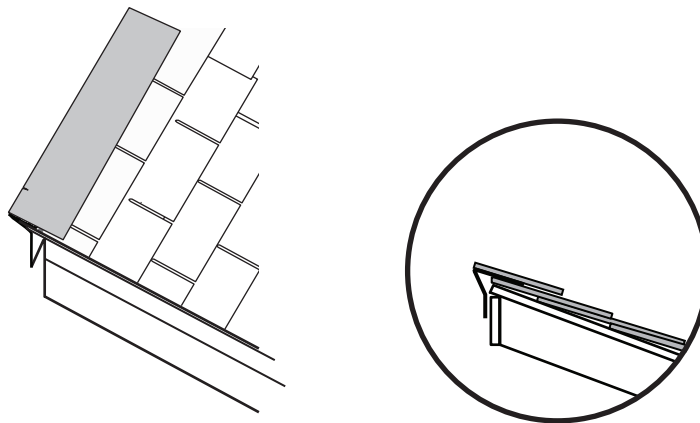

You have finished shingling your roof.

16572-B 10' x 8' Order Form

CATEGORY	PART DESCRIPTION	PART SIZE	PART ITEM #	BUILDING QTY.	PART ID	
2 X 3	Gable Fascia Backer	LUM SPF 2 X 3 X 72 #2&BTR	Q 72000000000	2	OY	
	Gable Fascia Backer	2 X 3 X 33 1/8" 15" O/E	Q 33021500000	2	BQA	
	Front Eave Extensions	2 X 3 X 10-1/2" EAVE EXTENSIO	Q 10081515000	9	BRA	
	Back Wall Filler	LUM SPF 2X3X96 #2&BTR	12115	1	PT	
	Back Wall Filler	2 X 3 X 35 1/4" CONNECTOR	Q 35040000000	1	FS	
2 X 4	Back Wall Studs	2 X 4 X 64" PRE-CUT & PART	O 64000000000	6	UX	
	Back Wall Top & Bottom Plates	*LUM SPF 2X4X72 #2&BTR	O 72000000000	3	TM	
	Back Wall Top & Bottom Plates	2X4X48" DOUBLER/ PLATE/ CRATE	O 48000000000	3	SP	
	Side Wall Studs	2 X 4 X 72-5/8" 15" O/E STUD	O 72100000150	2	BFA	
	Side Wall Studs	2 X 4 X 79 1/8" 15" O/E STUD	O 79020000150	2	BJA	
	Side Wall Studs	2 X 4 X 85 1/2" 15" O/E STUD	O 85080000150	2	BKA	
	Front Wall Framing Bottom plate	2 X 4 X 28" CONNECTOR	O 28000000000	2	RR	
	Front Wall Framing	2 X 4 X 86" CRATE LONG SIDE	O 86000000000	4	BLA	
	Front Wall Framing	2 X 4 X 68" STUD	O 68000000000	2	UM	
	Front Wall Framing Header	2 X 4 X 94 1/2" DOUBLER	O 94080000000	1	UN	
	Front Wall Framing Top Plate	2 X 4 X 45 5/8" TOP PLATE	O 45100000000	2	BMA	
	Front Wall Framing Top Plate	2 X 4 X 74-1/4" STUD	O 74040000000	2	BNA	
	Front Wall Framing Cripplers	2 X 4 X 16-1/2"	O 16080000000	4	RD	
	Rafters	2 X 4 X 93 3/16" 15" 15" RAFT	O 93031515000	9	BOA	
	2 X 4 TREATED FLOOR FRAME	Floor Bonds	LUM TRTD 2 X 4 X 72 #2&BTR	P 72000000000	2	---
		Floor Bonds	LUM TRTD 2 X 4 X 48 #2&BTR	P 48000000000	2	---
Floor Joists		LUM TRTD 2 X 4 X 87 #2&BT	P 87000000000	9	---	
1 X 3 PINE	Side Rake Framing	LUM SPF 1X3 X72" SQ EDGE PET	U 72000000000	2	HJ	
	Side Rake Framing	1 X 3 X 33-1/8" 15" O/E TRIM	U 33021500000	2	BPA	
	Gauge Block	1 X 3 X 5" PINE FILLER	U 05000000000	1	GAA	
7/16 OSB	Upper Roof Panel "A"	OSB 7/16" x 4' x 8'	11110	2	---	
	Upper Roof Panel "B"	7/16" OSB 35-7/8" X 96" ROOF P	C 96003514000	1	---	
	Small Roof Panel "C"	7/16" OSB 11 7/8" X 96"	C 96001114000	1	---	
	Small Roof Panel "D"	7/16" OSB 11 7/8" X 35-7/8"	C 35141114000	1	---	
5/8 OSB	Floor Panel "A"	OSB 5/8" X 4' X 8'	11117	1	---	
	Floor Panel "B"	5/8" OSB 42" X 96" FLOOR PANEL	E 96004200000	1	---	
	Floor Panel "C"	5/8" OSB 23 7/8" X 90" FLOOR P	E 90002314000	1	---	
NO GROOVE SIDING	Frontwall Panels	NG METROPOLITAN RGT FRONTWALL	K 96004800135	1	---	
	Frontwall Panels	NG METROPOLITAN LFT FRONTWALL	K 96004800235	1	---	
	Backwall Panels	SIDING NGSE 3/8X4'X6'	11509	2	---	
	Backwall Panels	3/8"NG 23 7/8" X72" PANEL OR	K 72002314000	1	---	
	Side Walls Long Panel- Right	NG METROPOLITAN RGT SIDEWALL	K 96004800100	1	---	
	Side Walls Long Panel- Left	NG METROPOLITAN LFT SIDEWALL	K 96004800200	1	---	
	Side Walls Short Panel-Right	NG METROPOLITAN RGT SIDEWALL	K 83024200100	1	---	
	Side Walls Short Panel-Left	NG METROPOLITAN LFT SIDEWALL	K 83024200200	1	---	
	Front Wall Panel	3/8" NG 11 7/8" X 96" FRONT	K 96001114000	2	---	
	Side Soffit Panels	3/8" NG 5 1/4" X 95 1/2" SOF	K 95080504000	2	---	
	Front Wall Soffit	3/8" NG 10 3/8" X 95 3/8" SO	K 95061006000	1	---	
	Front Wall Soffit	3/8" NG 10 3/8" X 35 3/4" SO	K 35121006000	1	---	
	Front Wall Frieze	3/8"NG2"X96"FRIEZE OR PRECUT	K 96000200000	1	---	
	Front Wall Frieze	3/8" NG 2" X 25 3/8" FRIEZE	K 25060200000	1	---	
	Corner Trim Back	3/8" NG 2" X 69 1/4" 15" O/E	K 69040200150	1	---	
	Corner Trim Back	3/8" NG 2" X 69 1/4" 15" O/E	K 69040200250	1	---	
	Corner Trim Back	3/8" NG 2" X 68 3/4" CORNER	K 68120200000	2	---	
	Corner Trim Front	3/8" NG 2" X 91 1/4" CORNER	K 91040200000	2	---	
	Corner Trim Front	3/8" NG 2" X 93 1/4" 15" O/E	K 93040200150	1	---	
	Corner Trim Front	3/8"NG 2" X 93 1/4" 15" O/E	K 93040200250	1	---	
19/32 X 3 SMART TRIM	Horizontal Door Rail	19/32 TST 2 1/2" X 26 5/8"	UT26100208000	8	AH	
	Transom Window Trim & Above Door	19/32 TST 2 1/2" X 91"	UT91000208000	2	BSA	
	Transom Window Trim	19/32 TST 2 1/2" X 9" TRIM	UT09000208000	4	EY	
19/32 X 4 SMART TRIM	Front Eave Trim	19/32 TST 3 1/2" X 80"	UT80000308000	1	BTA	
	Front Eave Trim	19/32 TST 3 1/2" X 52 3/8" EAV	UT52060308000	1	BUA	
	Gable Trim - Right	19/32 TST 3 1/2" X 59-1/4" 15"	UT59040308150	1	BXR	
	Gable Trim -Left	19/32 TST 3 1/2" X 59-1/4" 15"	UT59040308250	1	BXL	
	Gable Trim	19/32 TST 3 1/2" X 48"	UT48000308000	2	ZT	
	Back Eave Trim	19/32 TST 3 1/2" X 96"	UT96000308000	1	ZX	
	Back Eave Trim	19/32 TST 3 1/2" X 35 1/4" BA	UT35040308000	1	BYA	
Door Trim Gauge Block	19/32 TST 3 1/2" X 11 3/8"	UT11060308000	1	EHT		
PURCHASED COMPONENTS	Door Stiffener	LSL 1-1/4 X 2-1/4 X 69 PET	12715	2	OO	
	Single Point Locking Handle	HANDLE - T 5-1/2" SHAFT & "D"	15375	1	---	
	Hardware Kit	H/K METROPOLITAN 10X8	15879	1	---	
	Exterior Vent- white	VENT 16" X 8" EXTERIOR (WHITE)	15002	2	---	
	Transom window (single)	WINDOW 9 X 27 TRANSOM (SINGLE)	15235	3	---	
PACKAGING	Instructions		16572-B	1	---	
	Instructions		16572-FP	1	---	
Left Door Assembly	30145-L LEFT DOOR ASSEMBLY					
	Left Door Panel	NG 31 1/4" X 70 1/2" LEFT DOOR	K 70083104200	1	---	
	Left Hinge Assembly	HINGE LEFT (GREEN) 19/32x3 THIN TRIM	30131-TT	1	---	
	Vertical Door Stiles	19/32 TST 2 1/2" X 71 5/8"	UT71100208000	1	GY	
Horizontal Lower Door Rail	19/32 TST 2 1/2" X 26 5/8"	UT26100208000	2	AH		
Right Door Assembly	30145-R RIGHT DOOR ASSEMBLY					
	Right Door Panel	NG 31 1/4" X 70 1/2" RIGHT DOO	K 70083104100	1	---	
	Right Hinge Assembly	HINGE RIGHT (RED) 19/32x3 THIN TRIM	30121-TT	1	---	
	Vertical Door Stiles	19/32 TST 2 1/2" X 71 5/8"	UT71100208000	1	GY	
Horizontal Lower Door Rail	19/32 TST 2 1/2" X 26 5/8"	UT26100208000	2	AH		

LIMITED CONDITIONAL WARRANTY*

Backyard Storage Solutions, LLC warrants the following:

1. Every product is warranted from defects in workmanship and manufacturing for 1 year.
2. All accessories, hardware and metal components are warranted for 2 years.
3. All Oriented Strand Board (OSB) is warranted for 2 years
4. Siding and Trim is warranted for 10 years.
5. Solar Shed windows are warranted for 1 year.
6. Cedar lumber is warranted for 15 years.
7. Preserved Pine is warranted for 10 years.
8. Redwood is warranted for 10 years.

Backyard Storage Solutions, LLC will repair, replace or pay for the affected part. In no event shall Backyard Storage Solutions, LLC pay the cost of labor or installation or any other costs related thereto. All warranties are from date of purchase. If a cash refund is paid on an affected part, it will be prorated from the date of purchase.

CONDITIONS

The warranty is effective only when:

1. The unit has been erected in accordance with the assembly instructions.
2. The unit has been properly shingled and painted or stained and reasonably and regularly maintained thereafter.
3. The failure occurs when the unit is owned by the original purchaser.
4. Backyard Storage Solutions, LLC has received the warranty registration card within thirty (30) days of purchase and notification of the failure in writing within the warranty period specified above.
5. Backyard Storage Solutions, LLC has had reasonable opportunity during the sixty (60) days following receipt of notification to inspect and verify the failure prior to commencement of any repair work.

REQUIREMENTS

Storage Buildings

To validate your warranty, it is necessary to properly maintain your Backyard Storage Solutions, LLC unit; shingle the roof and paint or solid-colored stain the siding using quality, 100% acrylic latex exterior product with a minimum of two (2) coats within thirty (30) days of assembly; caulk above all doors and all horizontal and vertical trim boards; paint and seal all exposed edges, sides and faces of siding/trim and OSB siding to include all exterior walls and all sides and all edges of doors.

Gazebos & Pergolas

To validate your warranty, it is necessary to properly maintain your Backyard Storage Solutions, LLC unit. This includes treating all of the exposed cedar and pine surfaces on your gazebo or pergola structure with an exterior grade wood preservative, an exterior oil-based semi-transparent stain, an acrylic latex exterior paint or an acrylic latex solid color exterior stain within 30 days of assembly and as needed thereafter to maintain your warranty.

Keep vegetation trimmed away from building and make sure siding panels and trim do not come in contact with masonry or cement. The minimum ground clearance for siding must be one half inch (½ inch) from concrete slab or two and one half inches (2 ½") from the ground when building is erected or constructed on a treated wood floor kit. Water from sprinklers must be kept off unit. In no event will Backyard Storage Solutions, LLC be responsible for any indirect, incidental, consequential or special damages nor for failure(s) that are caused by events, acts or omissions beyond our control including, but not limited to, misuse or improper assembly, improper maintenance (which eventually leads to rot or decay) and acts of God. Backyard Storage Solutions, LLC will not be held responsible for any labor costs incurred to construct your unit.

This warranty gives you certain specific rights that vary from state to state.

CLAIM PROCEDURE

To make a claim under this warranty, you can either call 1-888-827-9056 or email: customerservice@backyardproducts.com.

Please have ready the information below when you call or include the information in your email:

1. The model and size of the product.
2. A list of the part(s) for which the claim is made.
3. Proof of purchase of the Backyard Storage Solutions, LLC item, as shown on the original invoice or receipt.
4. Run code: found on exterior product label or assembly instructions enclosed in the product package.

All other inquiries can be mailed to:

Backyard Storage Solutions, LLC
Attn: Customer Service
1000 Terres
Monroe, MI 48162

***WARRANTY TERMS MAY VARY OUTSIDE THE U.S.A.
IMPORTANT: This is your warranty certificate.**

10Y MV LDR: 3/20/2019