

16252-A



STOP

DO NOT RETURN TO THE STORE!

If you discover missing or damaged parts, or if you have questions about the building process, please reach out to us directly for the fastest service.

24/7 Support

help.backyardproducts.com



- Answers to frequently asked questions
- Technical assistance and how-to videos
- Submit a help request
- Request replacement parts

Business Hours

(734) 242-6900

Monday - Friday 8:00am - 6:00pm EST
Saturday - Sunday Closed



Did you enjoy building your shed?

JOIN OUR TEAM

AND MAKE UP TO \$1,500/WEEK*

Call a Recruiter Today! 734-365-7000



Flexible schedule



No selling,
just building



Bonus incentives
available

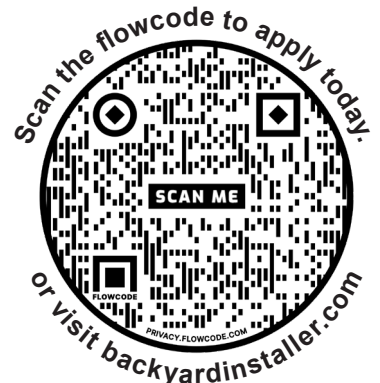

*based on number of completed installations

(This page is intentionally left blank.)

ASSEMBLY MANUAL

MODERN 12' x 7' -6" (365,8 x 228,6 cm)

ACTUAL FLOOR SIZE IS 144" x 90" (365,8 x 228,6 cm)

KEEP THIS MANUAL FOR FUTURE REFERENCE

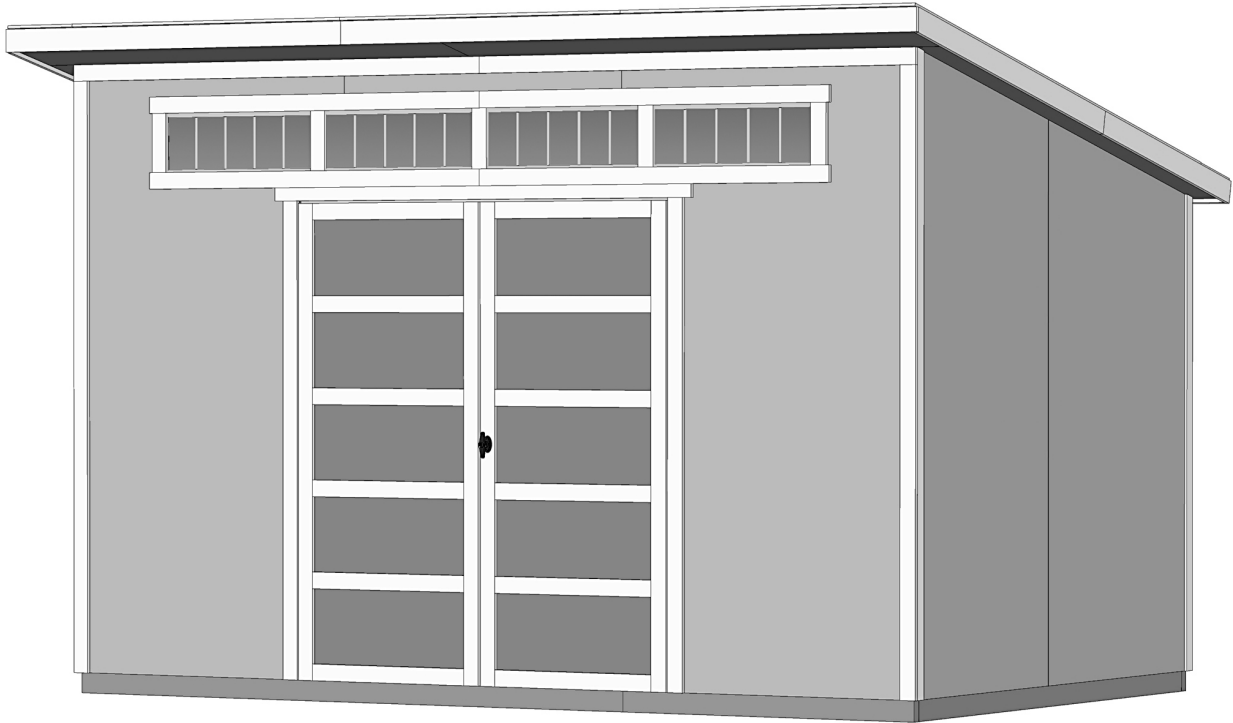

⚠ IMPORTANT! ⚠

READ INSTRUCTIONS THOROUGHLY PRIOR TO BEGINNING ASSEMBLY.

BEFORE YOU BEGIN

- **BUILDING RESTRICTIONS AND APPROVALS**

Be sure to check local building department and homeowners association for specific restrictions and/ or requirements before building.

- **ENGINEERED DRAWINGS**

Contact our Customer Service Team if engineered drawings are needed to pull local permits.

- **SURFACE PREPARATION**

To ensure proper assembly you must build your shed on a level surface. Recommended methods and materials to level your shed are listed on page 8.

- **CHECK ALL PARTS**

Inventory all parts listed on pages 4-7.

- **ADDITIONAL MATERIALS**

You will need additional materials to complete your shed. See page 3 for required and optional materials and quantities.

*****CONTACT OUR CUSTOMER SERVICE TEAM
IF ANY PARTS ARE MISSING OR DAMAGED*****

- Order form and warranty at back of manual -

Call: 1-734-242-6900 email: customerservice@backyardproducts.com



TOOLS

Required

Phillips Screwdriver 

Drill / Driver 
 1/4" Drill Bit
 3/8" Drill Bit
 1/2" Drill Bit
 #2 Phillips Drive Bit



Hammer 

Level 

Pencil 

Tape Measure 

Square  or 

Utility Knife 
 Shingle Blades 

Caulk Gun 

Paint Tools 

Safety Glasses 

Ladder 

Optional

Tool Belt/
Nail Pouch 

Tin Snips
(for drip edge) 

Pliers 

Chalk Line 

Nail Gun
• gun nails 

Gloves 

Safety! Always use approved safety glasses during assembly.

HELPFUL REMINDER SYMBOLS

Look for these symbols for helpful reminders throughout this manual.

 = Assistance Required; two or more people.

 = Ensure squareness.

 = Important required step or operation.

 = Helpful assembly hint.

 = Mark part with pencil.

 **BEGIN** = Beginning of steps for assembly or installation.

 **FINISH** = You have finishing the assembly or installation.

 = Level

ORIENT LUMBER AND TRIM FOR BEST APPEARANCE

Framing lumber is graded for structural strength and not appearance. Exterior trim is graded for one good side.

Always install the material leaving the best edge and best surface visible. Please remember that these blemishes in no way negatively affect the strength or integrity of our product. (See Fig. A, B, C.)

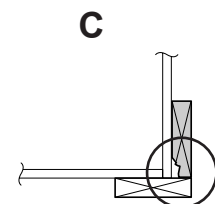
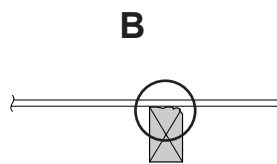
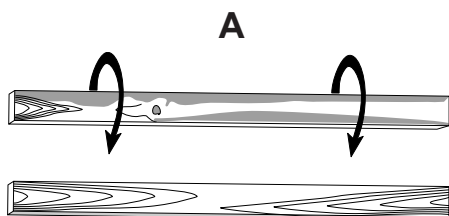

ADDITIONAL MATERIALS

FOUNDATION OR FLOOR MATERIALS

- This shed kit includes a complete wood floor system.
- This shed kit does not include ANY leveling materials.
- See the **FLOOR LEVELING** section on page 8 for recommended methods and suggested materials to properly level your floor, as this will vary depending on your specific site.

REINFORCED WOOD FLOOR FRAME (OPTIONAL)

IMPORTANT! The included floor has been designed for general use. Depending on your specific use you may want to construct a heavy duty floor frame by adding additional floor joists (shown below). Below is a list of additional materials (not included):

x3 2 x 4 x 87" (5 x 10 x 221 cm) Treated Lumber

x12 ea. 3" (7,6 cm) Hot Dipped Galvanized Nails

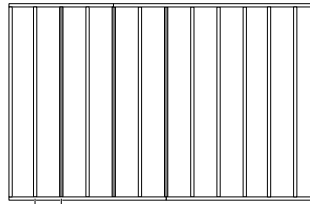

Optional 12" (30,1 cm) spacing.
• Standard spacing is 16" (40,7 cm).

COMPLETING YOUR SHED

You will need these additional materials:

3-TAB SHINGLES 5 Bundles

PAINT FOR SIDING 2 Gallons
Use 100% acrylic latex exterior paint. (2) coats recommended.

CAULK 2 Tubes
Use acrylic latex exterior caulk that is paintable. 

DRIP EDGE 50 Feet

1" GALVANIZED ROOFING NAILS.... 3 Lbs
For shingles.

PAINT FOR TRIM 1 Quart
Use 100% acrylic latex exterior paint.

1" GALVANIZED ROOFING NAILS....1/4 Lb
For roofing felt.

#15 ROOFING FELT
To cover 134 Sq. Ft. of roof area.

FRAMING NAILS

Boxed Nails -Or- Nail Gun Strip/Coil Nails

x4 lbs.

x300

x4 lbs.

x850

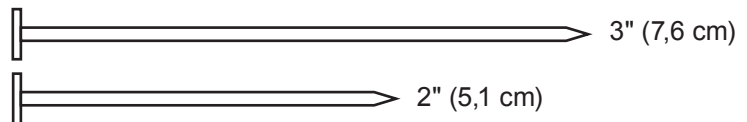

TO VALIDATE YOUR WARRANTY YOU MUST USE THE FOLLOWING:



CAULK 1 Tube
For windows
Use acrylic latex exterior caulk that is paintable. 

REFER TO THE BACK OF THIS MANUAL AND THE MANUFACTURER'S INSTRUCTIONS FOR INSTALLATION OF SHINGLES, DRIP EDGE AND FELT.

PARTS IDENTIFICATION AND SIZES

Part identification letters are stamped on some parts.



Check these locations for part stamp.

Treated lumber is stamped:

TREATED

WOOD SIZE CONVERSION CHART



Nominal Board Size	Actual Size
2 x 4	1-1/2" x 3-1/2" (3,8 x 8,9 cm)
1 x 4	3/4" x 3-1/2" (1,9 x 8,9 cm)
2 x 3	1-1/2" x 2-1/2" (3,8 x 6,3 cm)
1 x 3	3/4" x 2-1/2" (3,8 x 6,3 cm)

PARTS LIST















INVENTORY YOUR PARTS before you begin.

We suggest sorting parts by the category they are listed in.

FLOOR



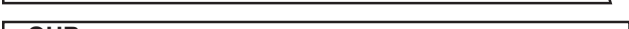
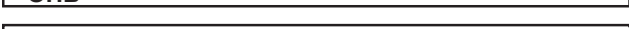

- x2  2 x 4 x 48" (5,1 x 10,2 x 121,9 cm)
- x10  2 x 4 x 87" (5,1 x 10,2 x 220,9 cm)
- x2  2 x 4 x 96" (5,1 x 10,2 x 243,8 cm)

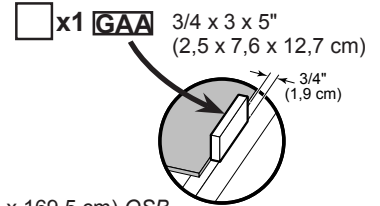
WALLS







- x5  2 x 4 x 12-1/8" (5,1 x 10,2 x 30,8 cm)
- x2  2 x 4 x 40" (5,1 x 10,2 x 101,6 cm)
- x4  2 x 4 x 48" (5,1 x 10,2 x 121,9 cm)
- x1  2 x 3 X 59-1/4" (1,1 x 7,6 x 150,5 cm)
- x2  7/16" x 3 1/4" X 66-3/4" (1,1 x 8,3 x 169,5 cm) OSB
- x2  2 x 4 x 67" (5,1 x 10,2 x 170,2 cm)
- x7  2 x 4 x 68" (5,1 x 10,2 x 172,7 cm)
- x2  2 x 4 x 68-9/16" (5,1 x 10,2 x 174,1 cm)
- x2  2 x 4 x 70-1/2" (5,1 x 10,2 x 179,1 cm)
- x2  2 x 4 x 72" (5,1 x 10,2 x 182,9 cm)
- x4  2 x 4 x 72-1/2" (5,1 x 10,2 x 184,2 cm)
- x2  2 x 4 x 78-1/16" (5,1 x 10,2 x 198,3 cm)
- x2  2 x 4 x 82-1/2" (5,1 x 10,2 x 209,6 cm)
- x2  2 x 4 x 86-1/8" (5,1 x 10,2 x 218,8 cm)
- x2  2 x 4 x 86-15/16" (5,1 x 10,2 x 220,8 cm)
- x1  2 x 3 x 96" (5,1 x 7,6 x 243,8 cm)
- x4  2 x 4 x 96" (5,1 x 10,2 x 243,8 cm)



RAFTERS



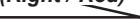









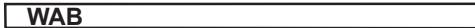



- x11  2 x 3 x 10-7/16" (5,1 x 7,6 x 26,5 cm)
- x2  1 x 3 x 31-15/16" (2,5 x 7,6 x 81,1 cm)
- x2  1 x 3 x 72" (2,5 x 7,6 x 182,8 cm)
- x11  2 x 4 x 92-3/16" (1,5 x 10,2 x 234,2 cm)

TRIM

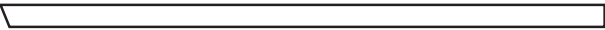

- x5  19/32" x 2-1/2" x 9" (1,5 x 6,3 x 22,9 cm)
- x1  3/8" x 1-1/2" x 9" (0,9 x 3,8 x 22,9 cm)
- x1  19/32" x 5-1/2" x 11-5/16" (1,5 x 14 x 28,7 cm)
- x1  (Right / Red) 3/8" x 2-11/16" x 12-1/4" (1,5 x 6,8 x 31,1 cm)
- x1  (Left / Green) 3/8" x 2-11/16" x 12-1/4" (1,5 x 6,8 x 31,1 cm)
- x8  19/32" x 2-1/2" x 26-5/8" (1,5 x 6,3 x 67,6 cm)
- x2  2 x 3 x 31-15/16" (5,1 x 7,6 x 81,1 cm)

PARTS LIST continued...

TRIM

- x2  19/32" x 3-1/2" x 45" (1,5 x 8,8 x 114,3 cm)
- x4  19/32" x 2-1/2" x 58-3/4" (1,5 x 6,3 x 149,2 cm)
- x1  19/32" x 3-1/2" x 59-1/4" (1,5 x 8,8 x 150,4 cm)
- x1  19/32" x 3-1/2" x 60-1/2" (1,5 x 8,8 x 153,7 cm)
- x1  19/32" x 3-1/2" x 61-1/16" (1,5 x 8,8 x 155,1 cm)
- x1  19/32" x 3-1/2" x 61-1/16" (1,5 x 8,8 x 155,1 cm)
- x2  69" (75,3 cm) Door Stiffener
- x1  19/32" x 2" x 72" (1,5 x 5,1 x 182,9 cm)
- x2  2 x 3 x 72" (5,1 x 7,6 x 182,8 cm)
- x2  19/32" x 2-1/2" x 72-3/4" (1,5 x 6,3 x 184,8 cm)
- x2  3/8" x 2" x 73-5/16" (0,9 x 5,1 x 186,2 cm)
- x1  3/8" x 2" x 73-7/16" (0,9 x 5,1 x 186,5 cm)
- x1  3/8" x 2" x 73-7/16" (0,9 x 5,1 x 186,5 cm)
- x2  19/32" x 2-1/2" x 90-5/8" (1,5 x 6,3 x 230,2 cm)
- x1  3/8" x 2" x 93-1/8" (0,9 x 5,1 x 236,5 cm)
- x1  3/8" x 2" x 93-1/8" (0,9 x 5,1 x 236,5 cm)
- x2  19/32" x 3-1/2" x 96" (1,5 x 8,8 x 243,8 cm)





SOFFIT

- x1  3/8" x 10-3/8" x 75-5/8" (1 x 26,3 x 192,1 cm)
- x1  3/8" x 10-3/8" x 79-5/8" (1 x 26,3 x 202,2 cm)
- x2  3/8" x 5-1/4" x 94-7/16" (1 x 13,3 x 242,5 cm)

PANEL PARTS LIST

Roof panels are 7/16" (1,1 cm) thick.



ROOF PANELS

- x1  7/16" x 10-11/16" x 28"
(1,1 x 27,1 x 71,1 cm)
- x1  7/16" x 10-11/16" x 31-7/8"
(1,1 x 27,1 x 81 cm)
- x1  7/16" x 10-11/16" x 96"
(1,1 x 27,1 x 243,8 cm)
- x1  7/16" x 11-7/8" x 96"
(1,1 x 30,2 x 243,8 cm)
- x3  7/16" x 48" x 96"
(1,1 x 121,9 x 243,8 cm)

NOTE: Panel parts are not stamped.

Floor panels are 5/8" (1,6 cm) thick.

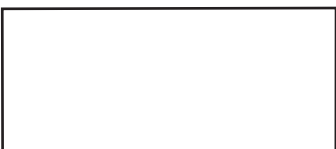
FLOOR

- x1  5/8" x 48" x 90"
(1,5 x 106,6 x 228,6 cm)
- x1  5/8" x 42" x 96"
(1,5 x 106,6 x 243,8 cm)
- x1  5/8" x 48" x 96"
(1,5 x 121,9 x 243,8 cm)

WALL PANEL & DOORS PARTS LIST



x3
3/8" x 48" x 76"
(1 x 113,3 x 193 cm)

x1
3/8" x 10-7/16" x 48"
(1 x 26,5 x 121,9 cm)

x1
3/8" x 4-1/2" x 48"
(1 x 11,4 x 121,9 cm)



x1
3/8" x 48" x 84"
(1 x 122 x 213,4 cm)



x1
3/8" x 48" x 84"
(1 x 122 x 213,4 cm)

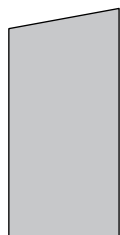

x1
3/8" x 42" x 96"
(1 x 106,7 x 243,8 cm)



x1
3/8" x 42" x 96"
(1 x 106,7 x 243,8 cm)

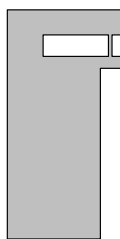

x1
3/8" x 48" x 96"
(1 x 121,9 x 243,8 cm)

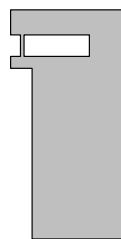

x1
3/8" x 48" x 96"
(1 x 121,9 x 243,8 cm)

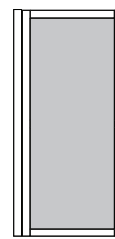

x1
Left Door

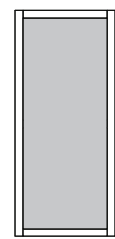

x1
Right Door

FASTENER / HARDWARE BAG

x100 3" (7,6 cm)

x100 2" (5,0 cm)

x2 1-1/4" (3,2 cm)

x90 3/4" (1,9 cm)

x265 1-1/2" (3,8 cm)

x230 2" (5,1 cm)

NOTE:

*If you are using a nail gun, nails may be used where screws are shown for quicker assembly.
Length of nail must match screw length.*

HARDWARE / WINDOWS / Misc.

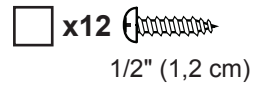
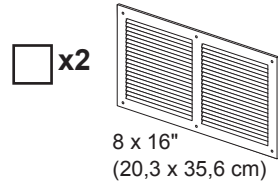
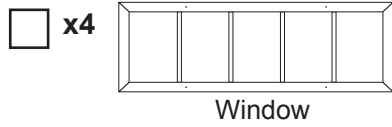
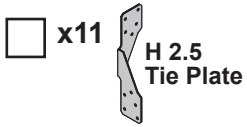

DOOR HARDWARE

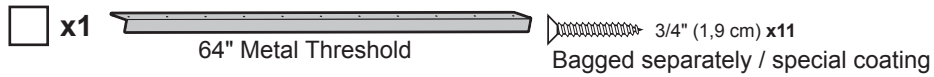
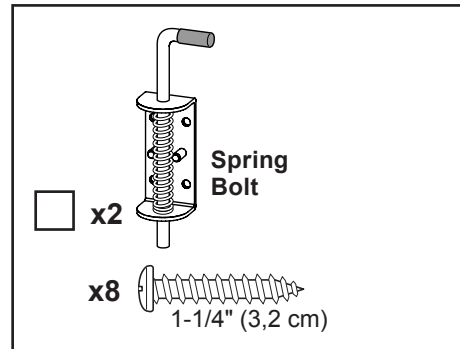
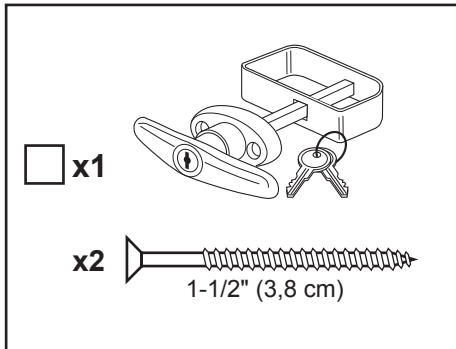

NOTES

FLOOR LEVELING OPTIONS

There are multiple ways to level your floor frame. Our recommended leveling method is shown below.
Leveling materials are not included in this kit.

PREFERRED METHOD - 4x4 TREATED RUNNERS

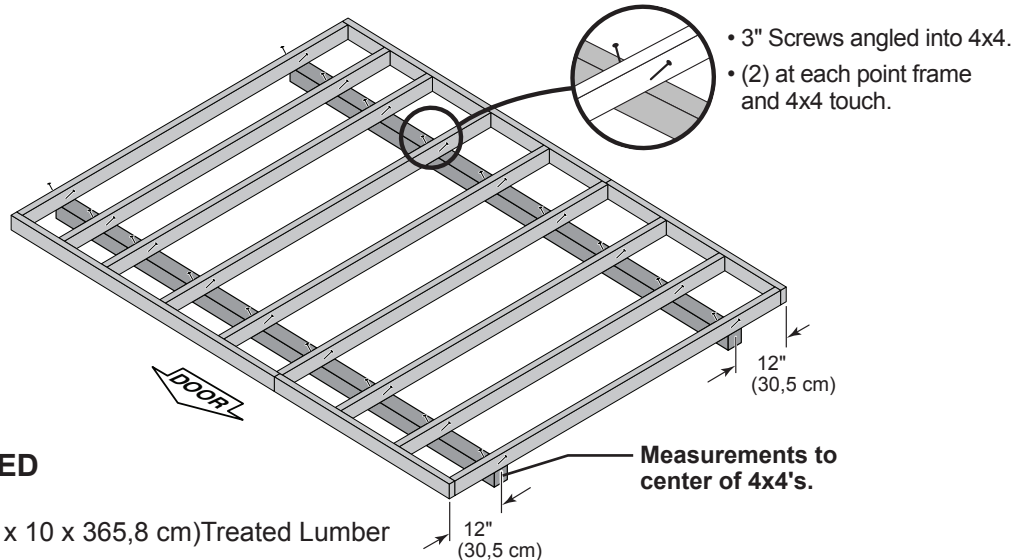

MATERIAL REQUIRED

x2 4 x 4 x 12' (10 x 10 x 365,8 cm) Treated Lumber

Fasteners for Frame to 4x4.
(3" Screws shown as one option.) Minimum (40) 3" screws / exterior grade.

Use only wood treated for ground contact and fasteners approved for use with treated wood.

Always support frame seams.

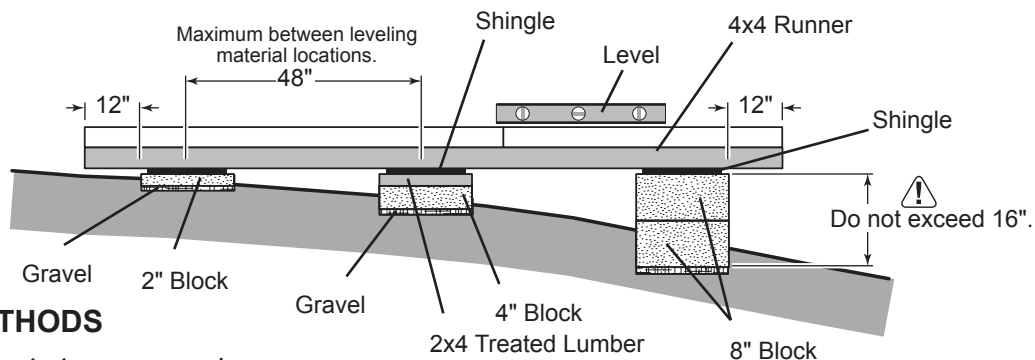

LEVELING METHODS

- Level under 4x4 runners only.
- Locate leveling material 12" from ends of runners and no more than 48" apart.
- Asphalt shingles should be used between 4x4 runners and blocks or treated lumber. Never use shingles in direct contact with ground.
- For best results and aiding in water drainage use gravel under each concrete block.

LEVELING MATERIALS

- Gravel
- Solid Masonry Blocks in 1", 2", 4" or 8" thickness
- 2x4 Treated Lumber
- Asphalt Shingles

Leveling higher than 16" not recommended.

CONCRETE

- If you are building your shed on a concrete foundation see the following page.

CONCRETE FOUNDATION

Your kit contains all materials to construct a wooden floor. If you choose to install your kit on a concrete slab refer to the diagram below.

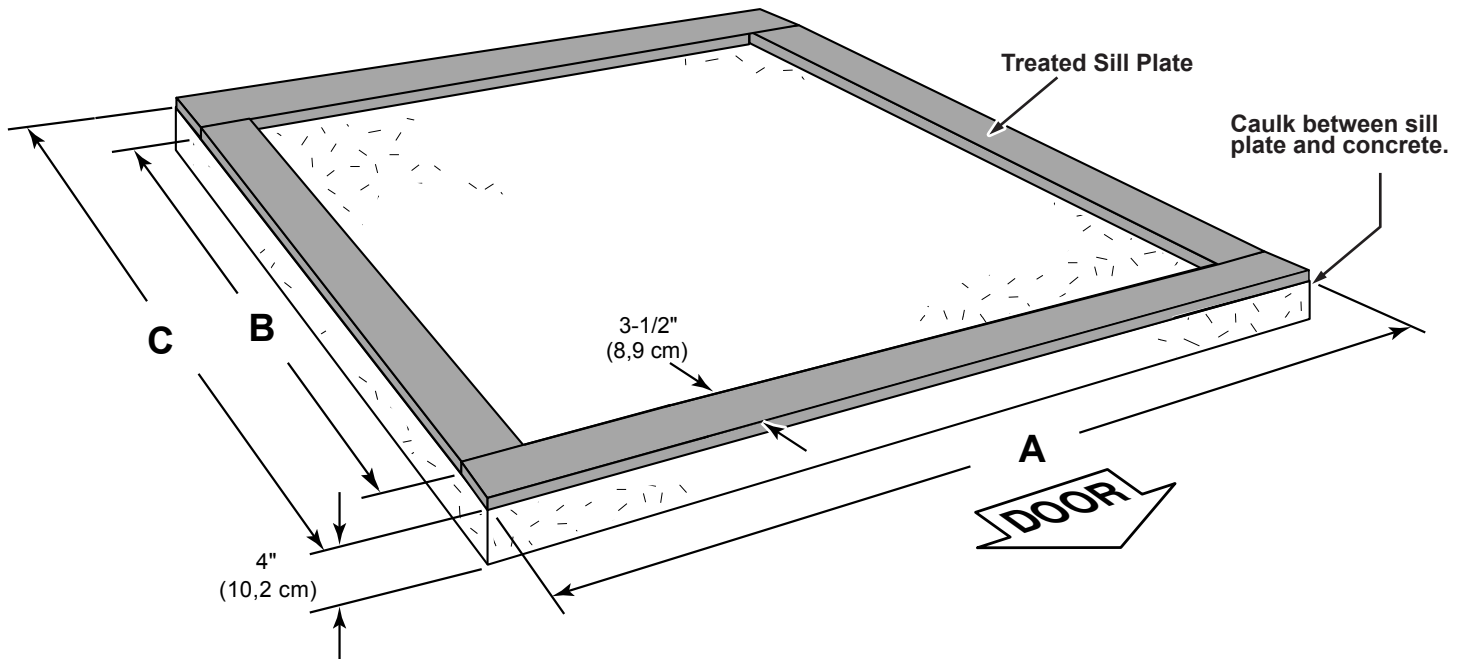

Building Size	Actual Size	A	B	C
12'x 7'-6" (365,8 x 228,6 cm)	144" x 90" (365,8 x 228,6 cm)	144" (365,8 cm)	83" (210,9 cm)	90" (228,6 cm)

Requires:

- x2** 2 x 4 x 12'-0" (5,1 x 10,2 x 365,8 cm) **MUST be treated lumber.**
- x2** 2 x 4 x 8'-0" (5,1 x 10,2 x 229,6 cm) **MUST be treated lumber.**
- x1** Caulk

Allow new concrete slabs to cure for at least seven (7) days.

• A treated 2 x 4 (5,1 x 10,2 cm) sill plate is required when installing your shed on concrete.
Hint: Use treated lumber in your kit or purchase full length treated lumber.

- Use a high quality exterior grade caulk beneath all sill plates.
- Fasten 2 x 4 (5,1 x 10,2 cm) sill plates to slab using approved concrete anchors (**fasteners not included**).
- Check local code for concrete foundation requirements.

NOTES

COMPONENT SECTION INDEX

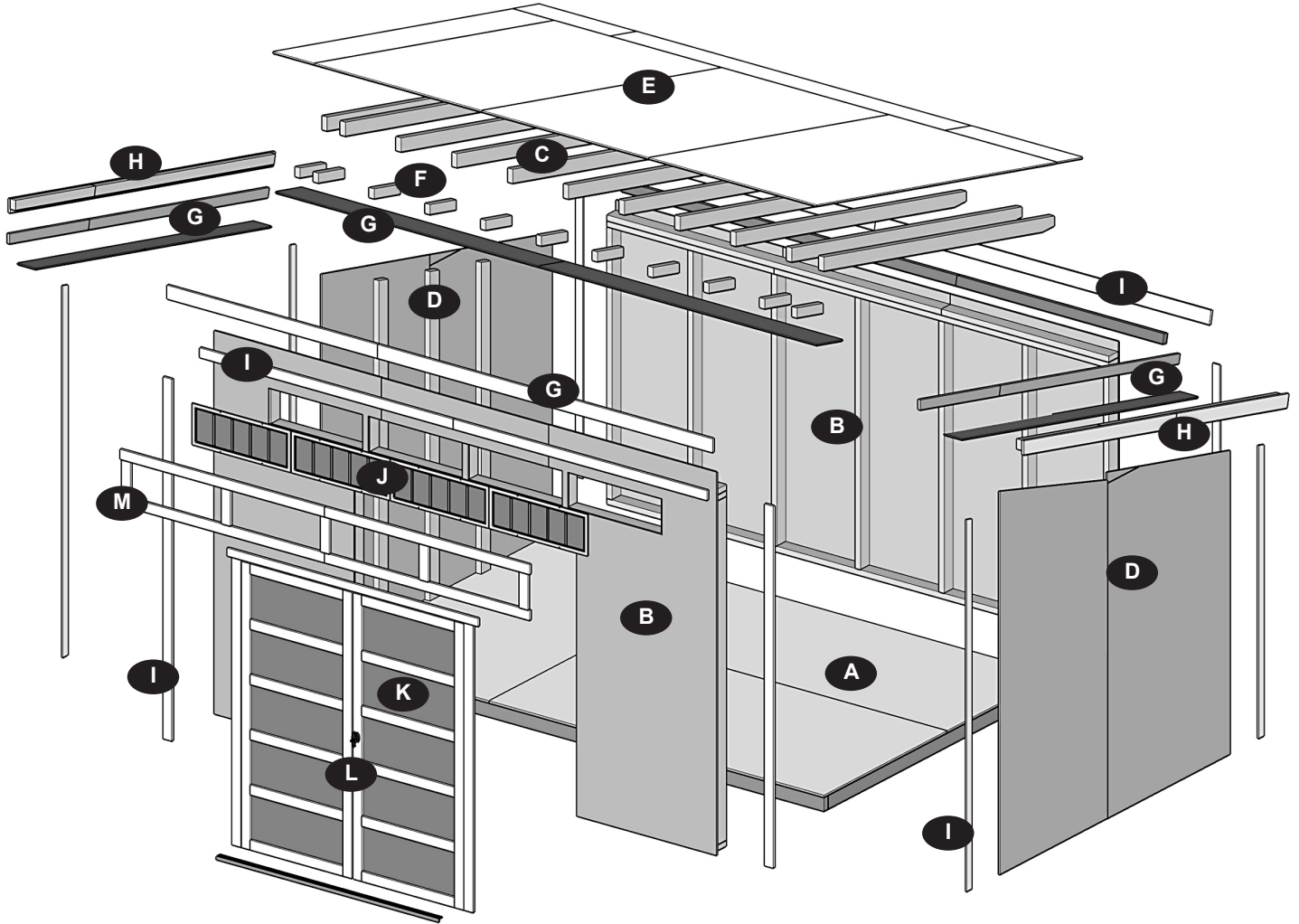



Description	Section	Page
Floor	A	11
Walls (front & back)	B	15
Rafters	C	27
Side Walls	D	31
Roof Panels	E	35
Rafter Extensions	F	39
Rake Framing	G	40
Soffit & Fascia	H	41
Wall Trim	I	50
Windows	J	53
Doors	K	54
Door HDW.	L	58
Window Trim	M	60
Shingles/Roofing		63

FLOOR FRAME

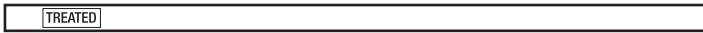
PARTS REQUIRED:

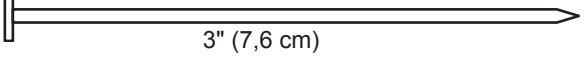
x10  2 x 4 x 87" (5,1 x 10,2 x 221 cm)

x44  3" (7,6 cm)

x2  2 x 4 x 96" (5,1 x 10,2 x 243,8 cm)

Look for
TREATED
Stamp

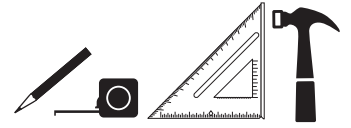

x2  2 x 4 x 48" (5,1 x 10,2 x 121,9 cm)

✓ BEGIN

- 1 Arrange parts as shown on flat surface. Measure and mark.
Secure with (2) 3" nails at each mark and (4) 3" nails at seams.



HINT:
For easier nailing
stand on frame.

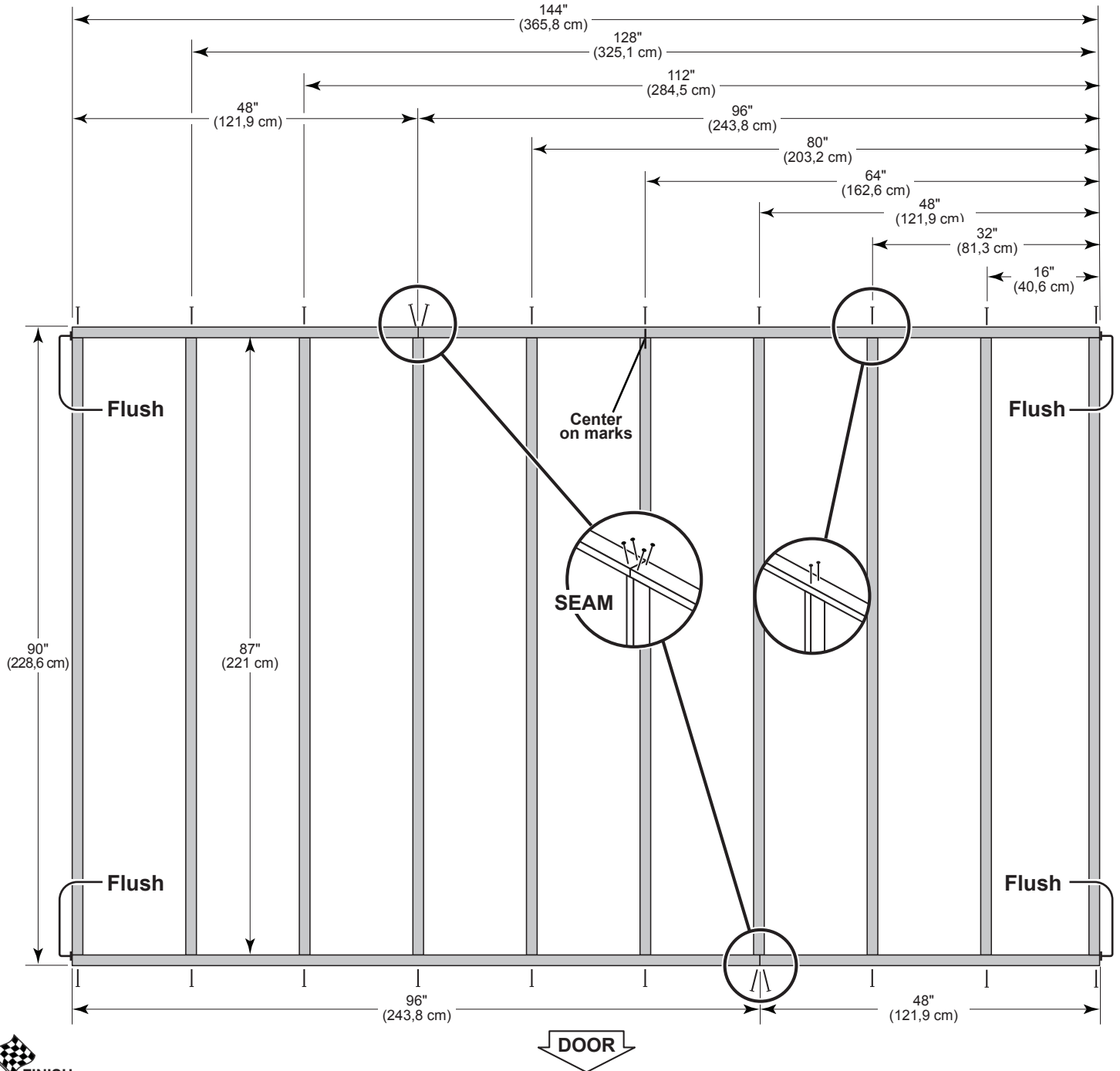
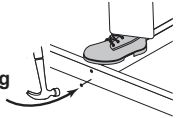

FINISH
Your floor frame is now assembled. Proceed to level and square frame.

STOP!



LEVEL AND SQUARE FLOOR FRAME



STOP!

Before installing floor decking, it is important to level and square the floor frame. A level and square floor frame is required to correctly construct your shed.

✓ **BEGIN**

- 1 See page 8 for the preferred floor leveling method.
- 2 Use level and check the frame is level before applying floor panels.
- 3 Check for frame squareness by measuring diagonally across corners. If the measurements are the same, the frame is square. The diagonal measurement will be approximately 169-13/16" (431,3 cm).
- 4 When the frame is level and square secure one side of frame to the 4x4 runners using one fastener at ends of each runner. Move to the opposite end of the frame. Secure the frame to 4x4 runners using one fastener at ends of each runner making sure the frame remains square (**Fig. A**).



FINISH

Once the floor frame is level and square, fasten the frame to the 4x4 runners at each point the frame contacts the 4x4 runners.

First, secure at ends using one fastener.

Fig. A

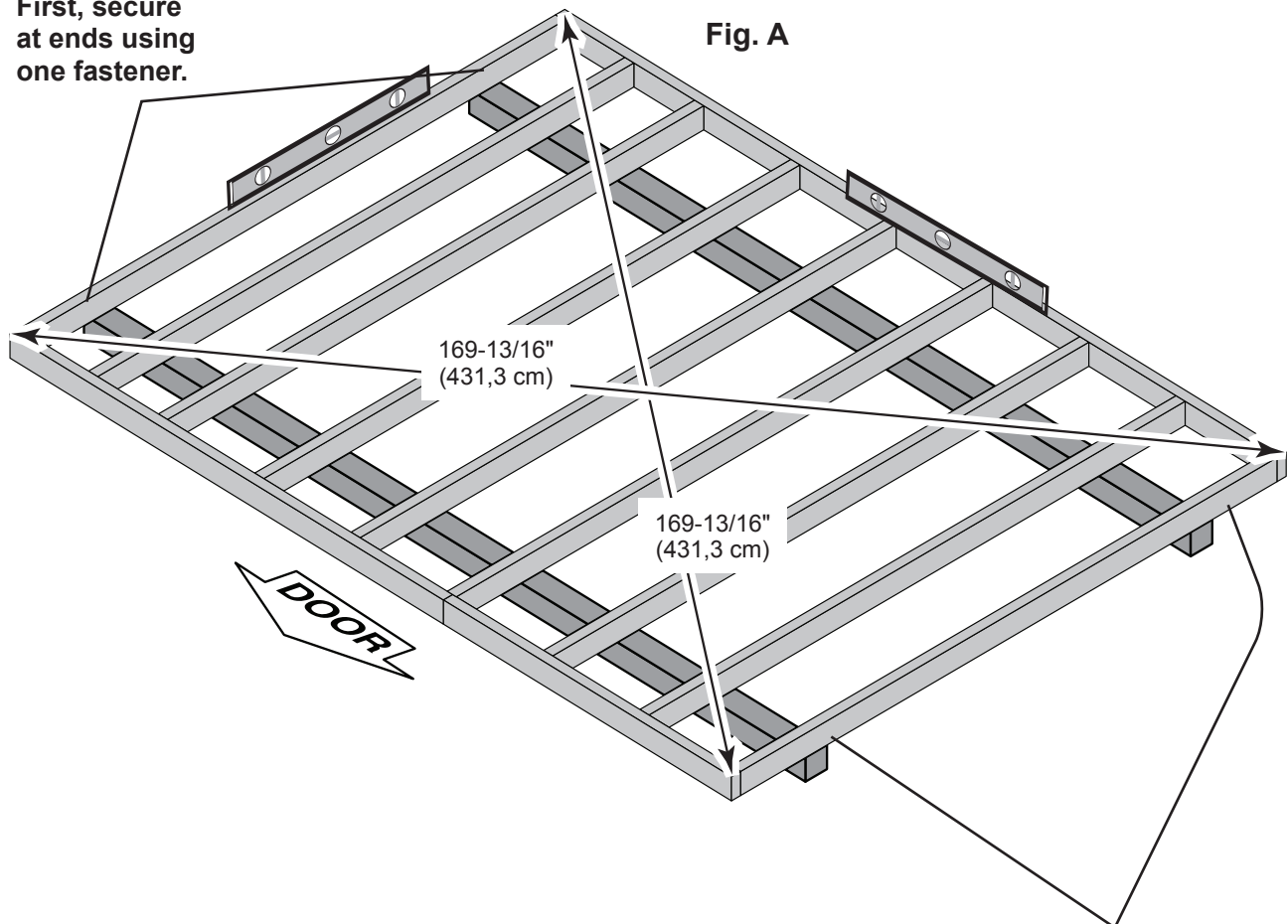

Second, secure at ends using one fastener.

FLOOR PANELS

PARTS REQUIRED:

x1  5/8" x 48" x 96"
(1,6 x 121,9 x 243,8 cm)

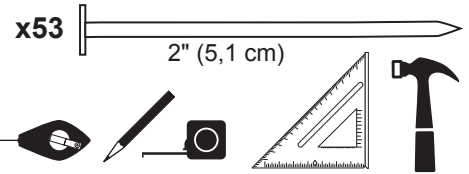

Install all panels with the rough side facing up (painted grid lines).

✓ BEGIN

- 1 Install the **48" x 96"** panel with the 48" edge and corner flush to the floor frame (**Fig A**). Secure panel with (2) 2" nails in the corners.
- 2 Move to the opposite side. Using the long edge of the panel as a lever, move the panel side-to-side until the top corner is flush to the floor frame (**Fig. B**). Secure panel with (2) 2" nails in the corners.
- 3 Continue securing the panel with 2" nails spaced 6" apart on edges and 12" apart inside panel.

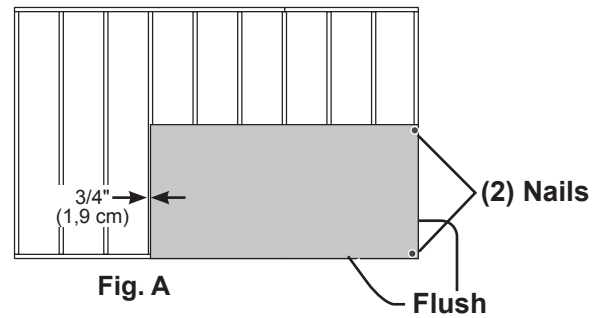

- 3 Continue securing the panel with 2" nails spaced 6" apart on edges and 12" apart inside panel.

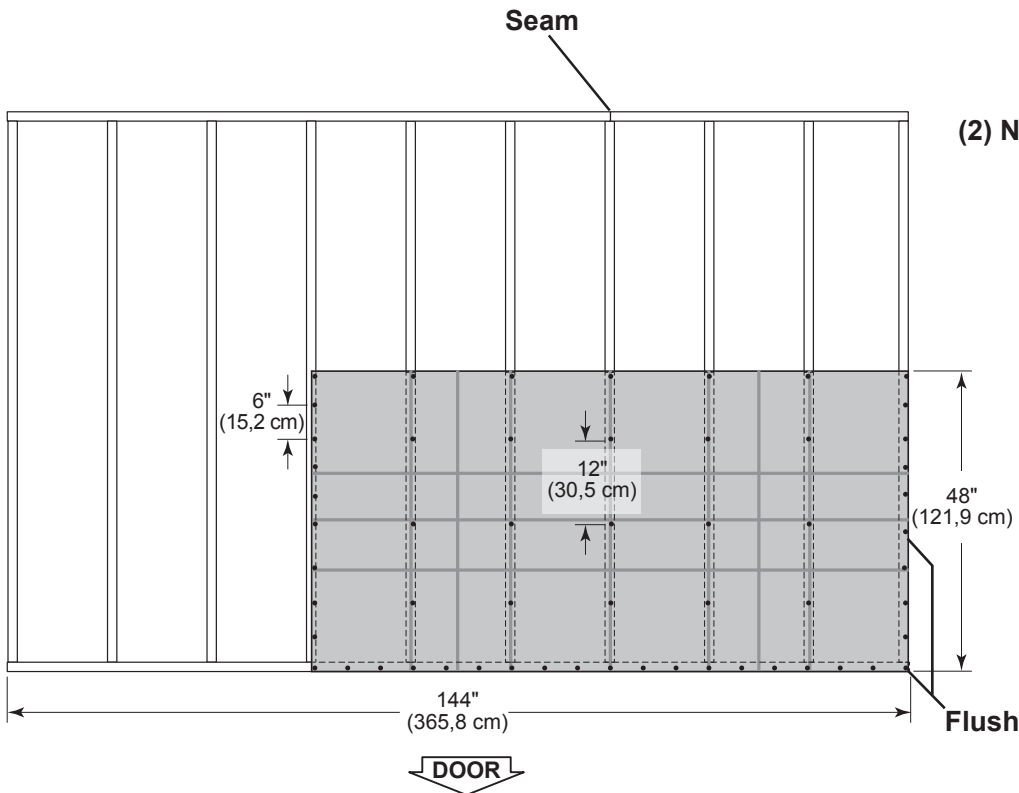
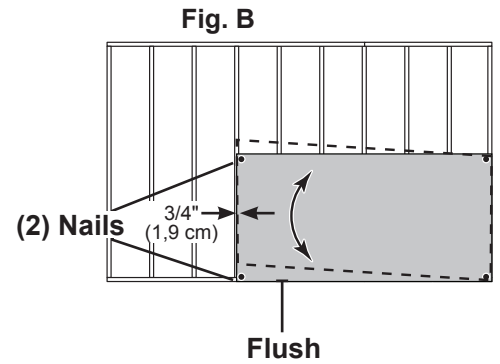

FLOOR PANELS

PARTS REQUIRED:

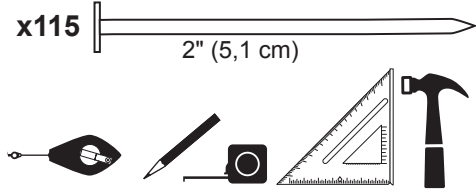
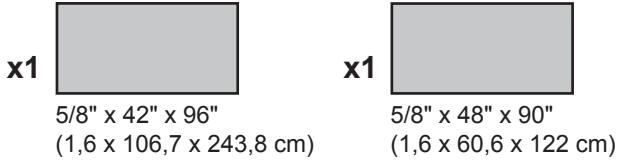

4 Continue installing panels with 2" nails spaced 6" apart on edges, and 12" apart inside panels.

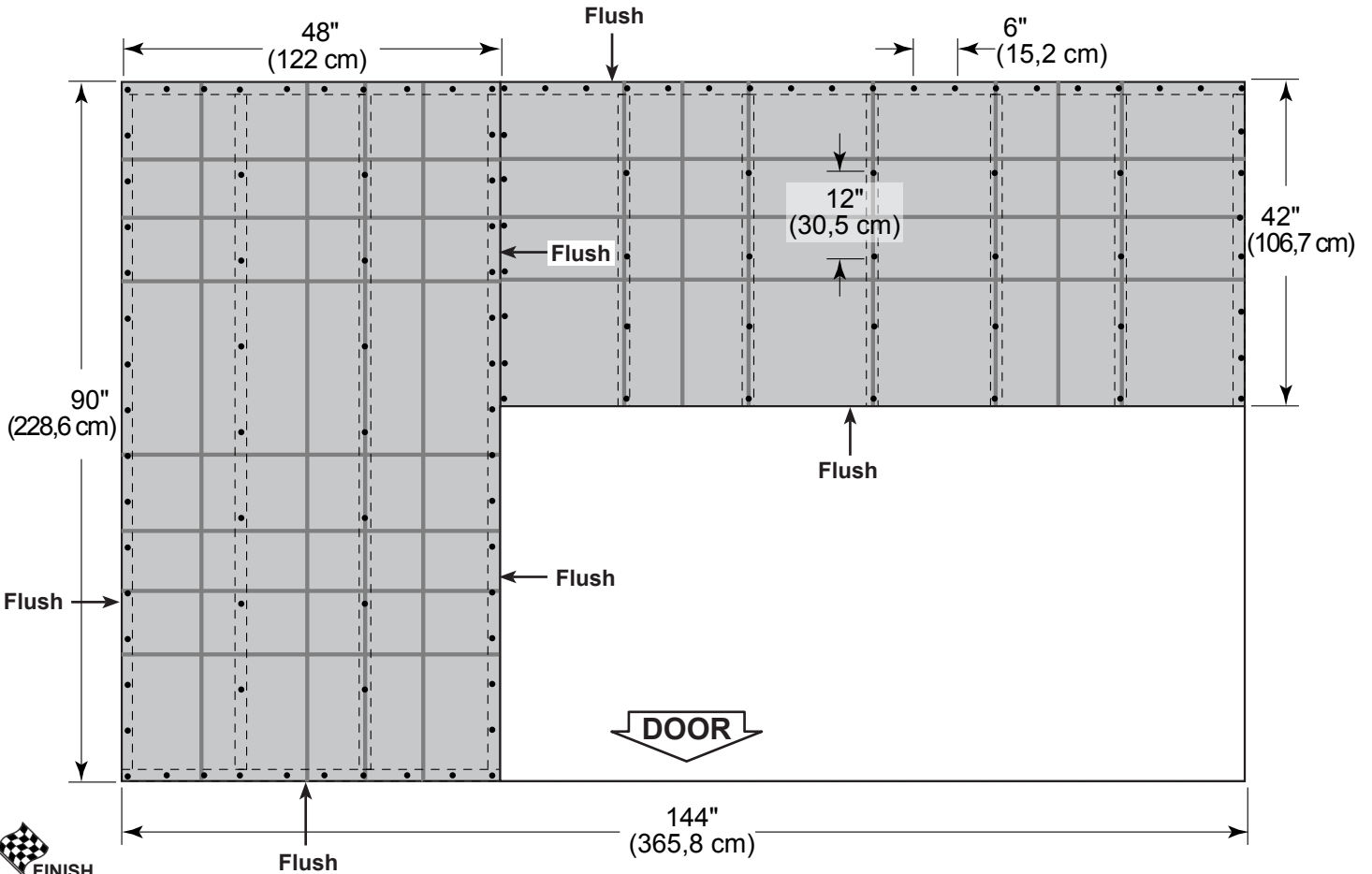

Your floor panels are now installed.

STOP! **IMPORTANT!** STOP!

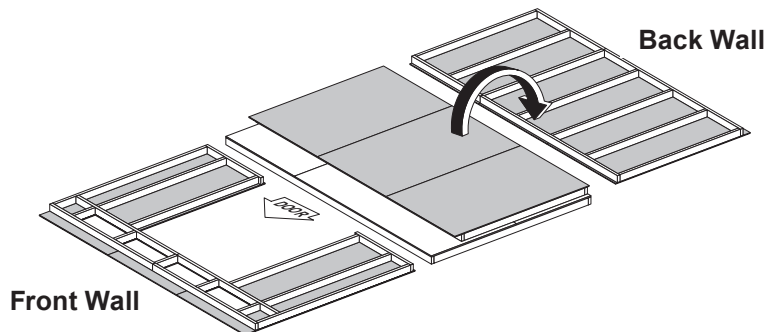
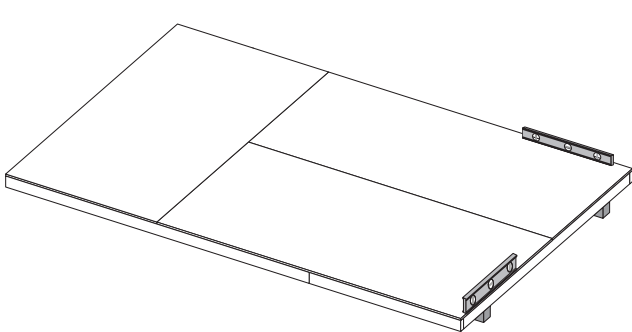

- Level the floor after installing floor panels. Re-level if needed.





HINT:

- The floor should be used as a stable work surface for wall construction.
- Organize your assembly procedure during the build process to avoid over-handling of the walls.

BACK WALL FRAME

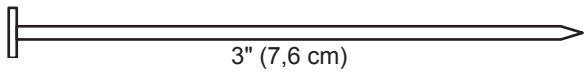
PARTS REQUIRED:

x32  3" (7,6 cm)

x2 **SP**  2 x 4 x 48" (5,1 x 10,2 x 121,9 cm)

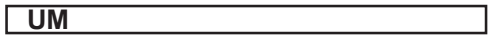
x7 **UM**  2 x 4 x 68" (5,1 x 10,2 x 172,7 cm)

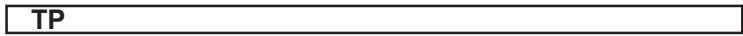
x2 **TP**  2 x 4 x 96" (5,1 x 10,2 x 243,8 cm)

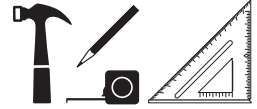

✓ BEGIN

1 Arrange parts on edge on floor. Measure and mark.

 **HINT:**
For easier nailing
stand on frame.

2 Secure with (2) 3" nails at each mark and (4) 3" nails at seams

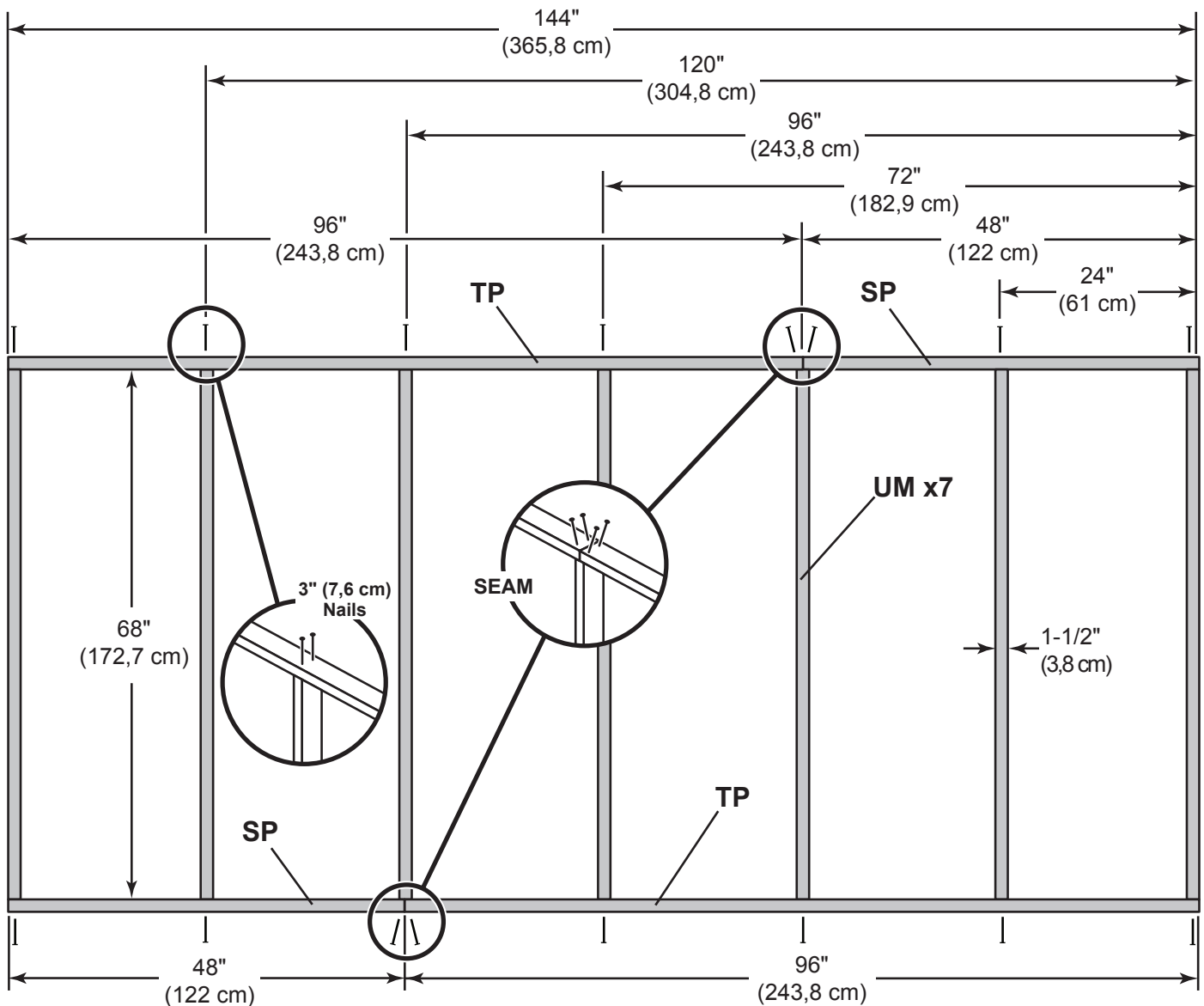
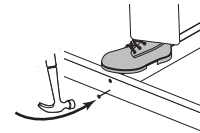

BACK WALL PANELS

PARTS REQUIRED:

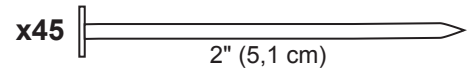

Install all panels with the primed side facing up.

• Ensure top of panel is overhanging the top of frame by 4".

3 Place **48" x 76"** panel on wall frame, as shown.

Use the gauge block to mark the 3/4" measurement on the wall stud.

Secure panel using 2" nails spaced 6" apart on edges and 12" apart inside panel.

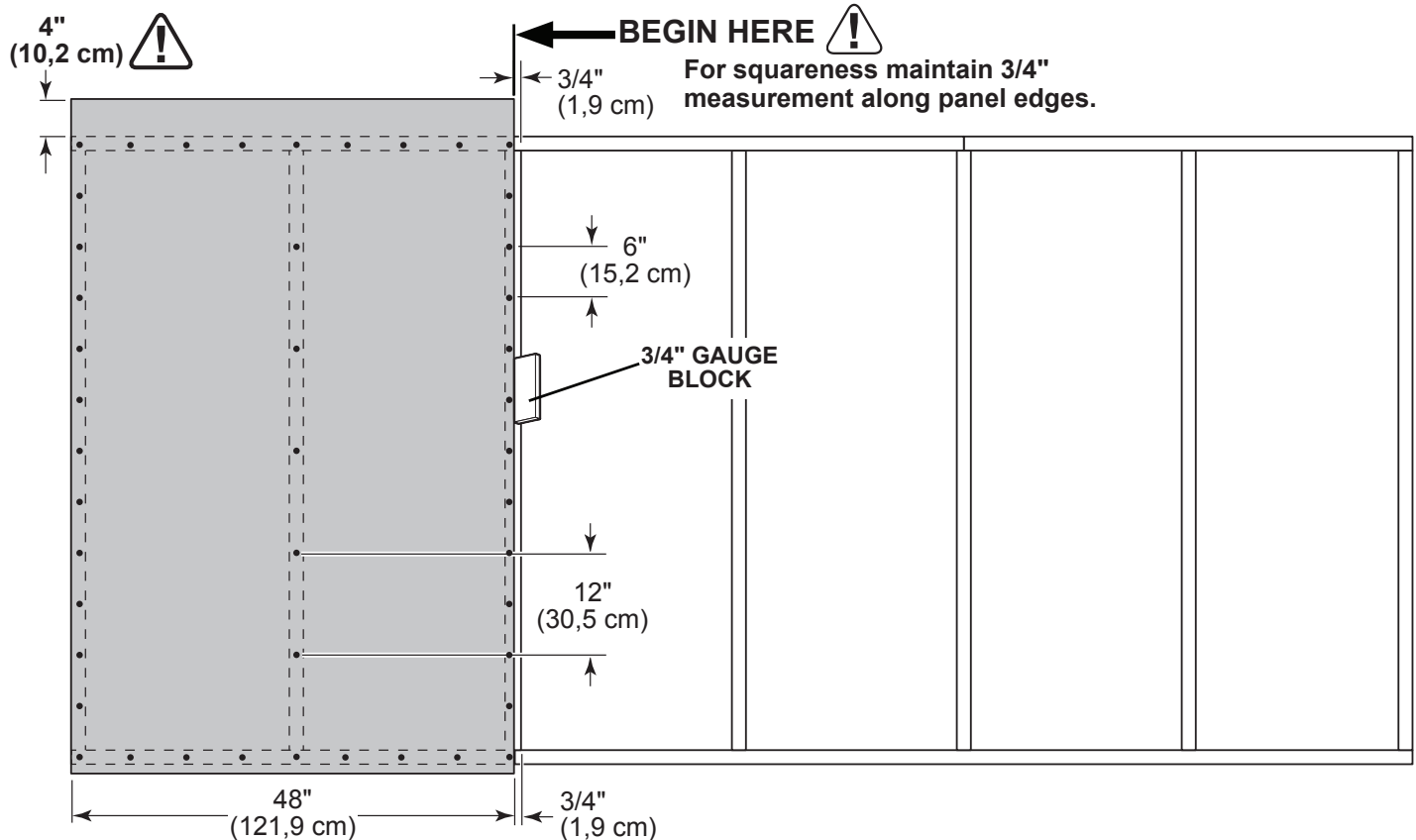

BACK WALL PANELS

PARTS REQUIRED:



x2

48" x 76"
(121,9 x 193 cm)



3/4" GAUGE
BLOCK

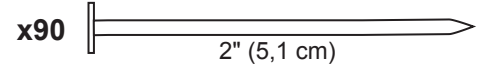

- Place center and end 48" x 76" panels on frame as shown (Fig. A, Fig. B).

Secure with 2" nails spaced 6" apart on edges and 12" apart inside panel.

! For squareness maintain 3/4" measurement along panel edges.

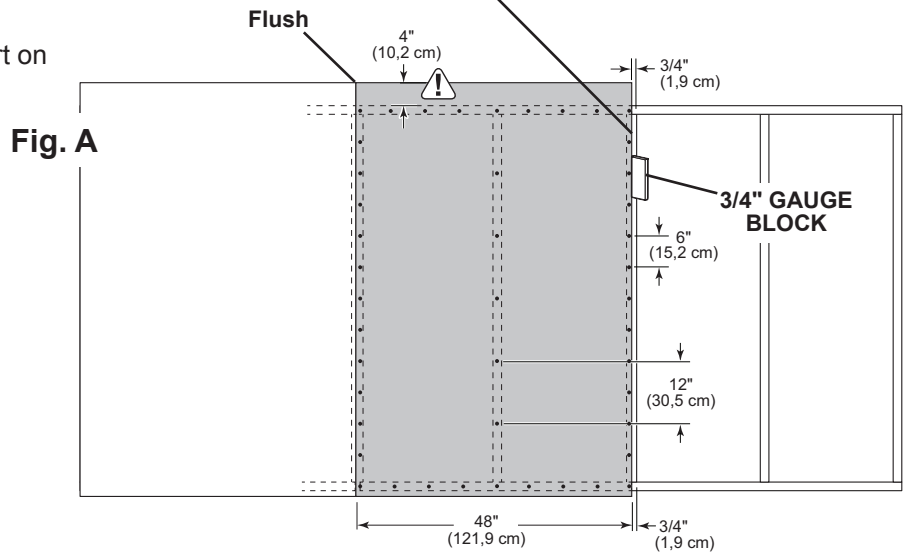

! For squareness maintain flush along panel edges.

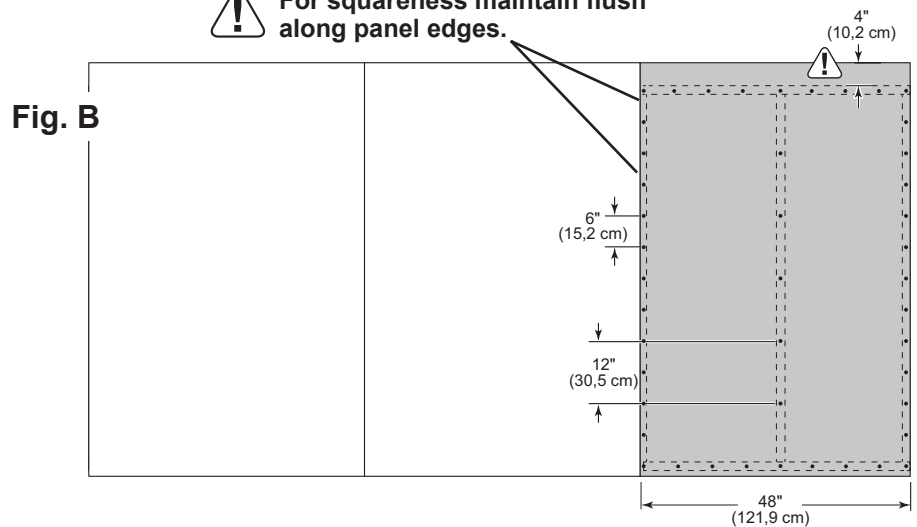

Your back wall is now assembled.

Carefully flip the back wall over.

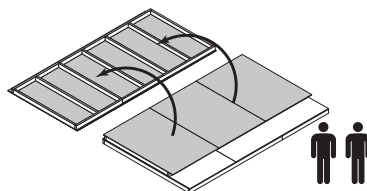

FRONT WALL - DOOR HEADER

PARTS REQUIRED:

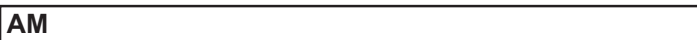
- x2 
7/16" x 3-1/4" x 66-3/4" (1,1 x 8,3 x 169,5 cm) OSB
- x2 **AM** 
2 x 4 x 67" (5,1 x 10,2 x 170,2 cm)

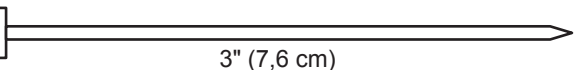
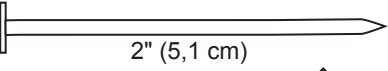
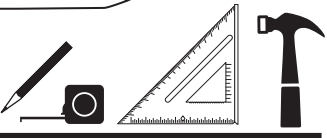
- x16 
3" (7,6 cm)
 - x6 
2" (5,1 cm)
- 

✓ BEGIN

1 Build header assembly as shown using 3" and 2" nails.

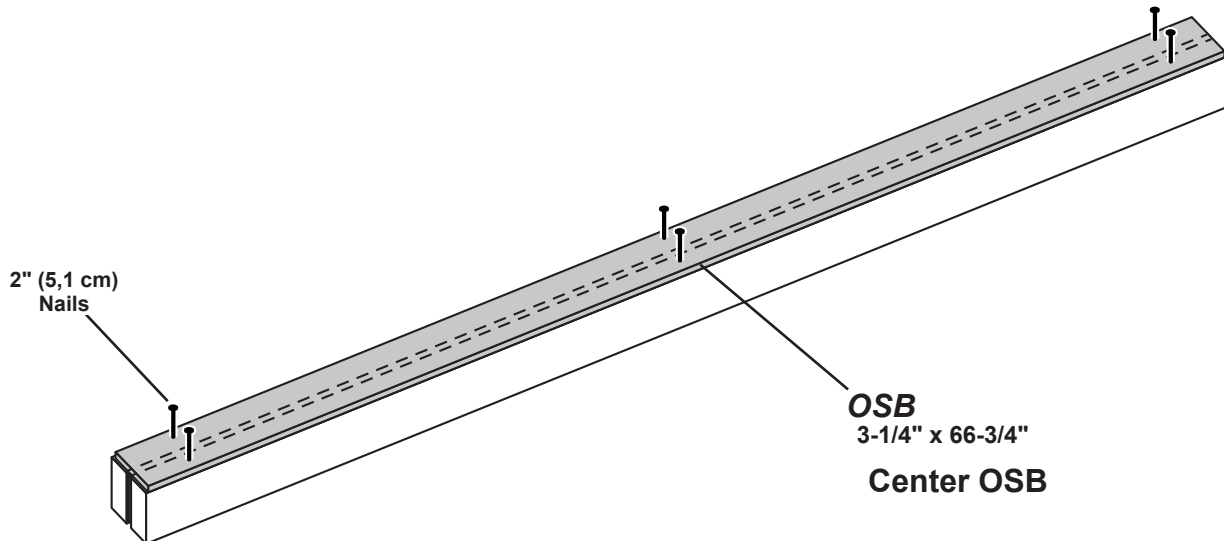
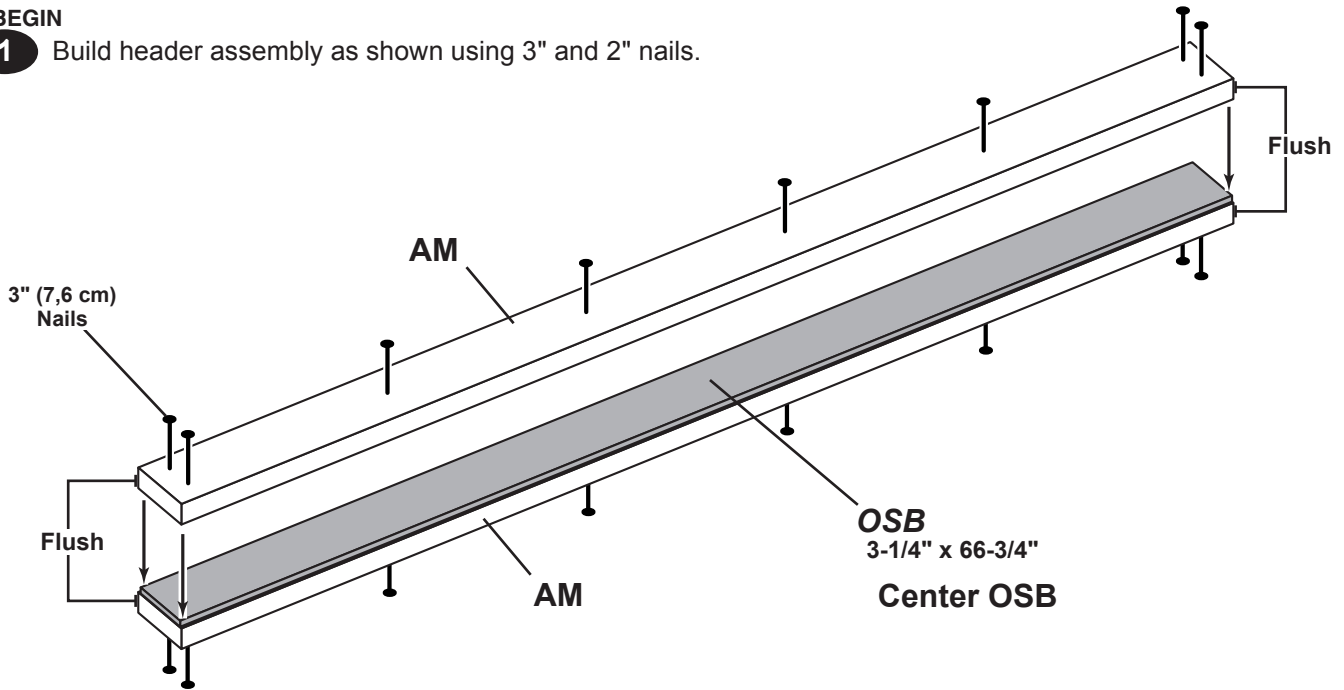

Your door header is now assembled.

FRONT WALL FRAME

PARTS REQUIRED:

x2 **SKA** 2 x 4 x 40" (5,1 x 10,2 x 101,6 cm)

x2 **AYA** 2 x 4 x 70-1/2" (5,1 x 10,2 x 179,1 cm)

x2 **TM** 2 x 4 x 72" (5,1 x 10,2 x 182,9 cm)

x4 **PTA** 2 x 4 x 72-1/2" (5,1 x 10,2 x 184,2 cm)

x2 **OHB** 2 x 4 x 86-1/8" (5,1 x 10,2 x 218,8 cm)

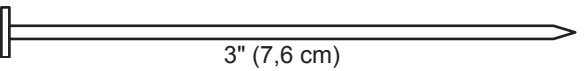
x56  3" (7,6 cm)

x5 **PPA** 2 x 4 x 12-1/8" (5,1 x 10,2 x 30,8 cm)

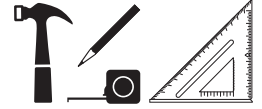

✓ BEGIN

- 1 Arrange parts on edge on floor. Measure and mark.
- 2 Secure with (2) 3" nails at each mark and (4) 3" nails at seams.

HINT:  For easier nailing stand on frame.

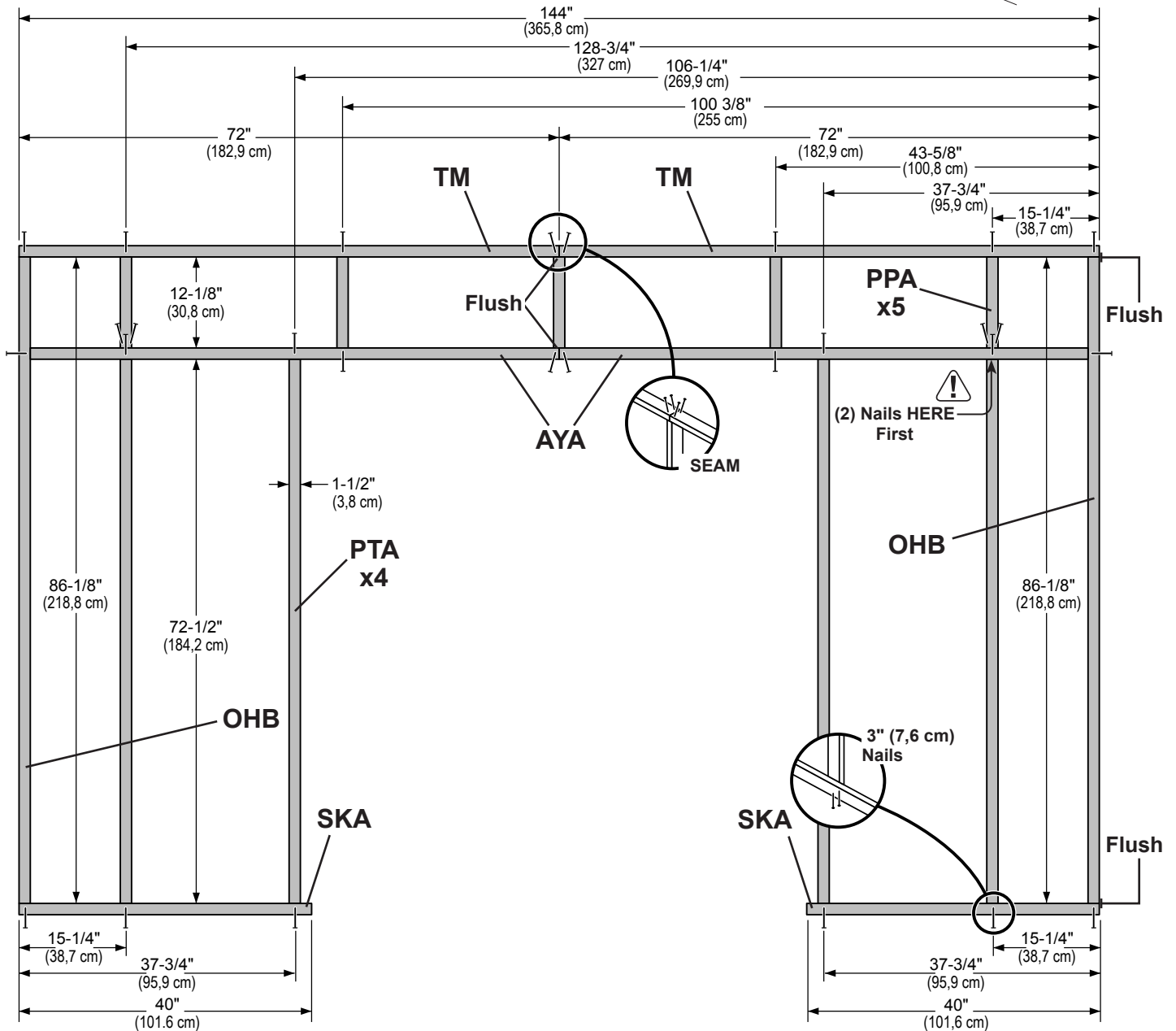
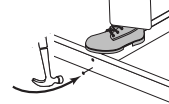

FRONT WALL FRAME

PARTS REQUIRED:

- x1 Pre-Assembled Door Header
4" x 67" (170,2 cm)
- x2 **NCE**
2 x 4 x 68-9/16" (5,1 x 10,2 x 174,1 cm)

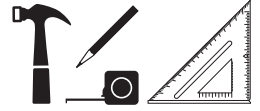
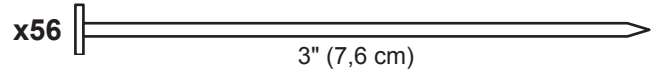

- 3 Install door header with **OSB** to the top of header.
Secure header with 3" nails at locations shown.
- 4 Arrange parts **NCE** on edge as shown.
Secure with (2) 3" nails at locations shown. Secure with (4) 3" nails into each side of header.

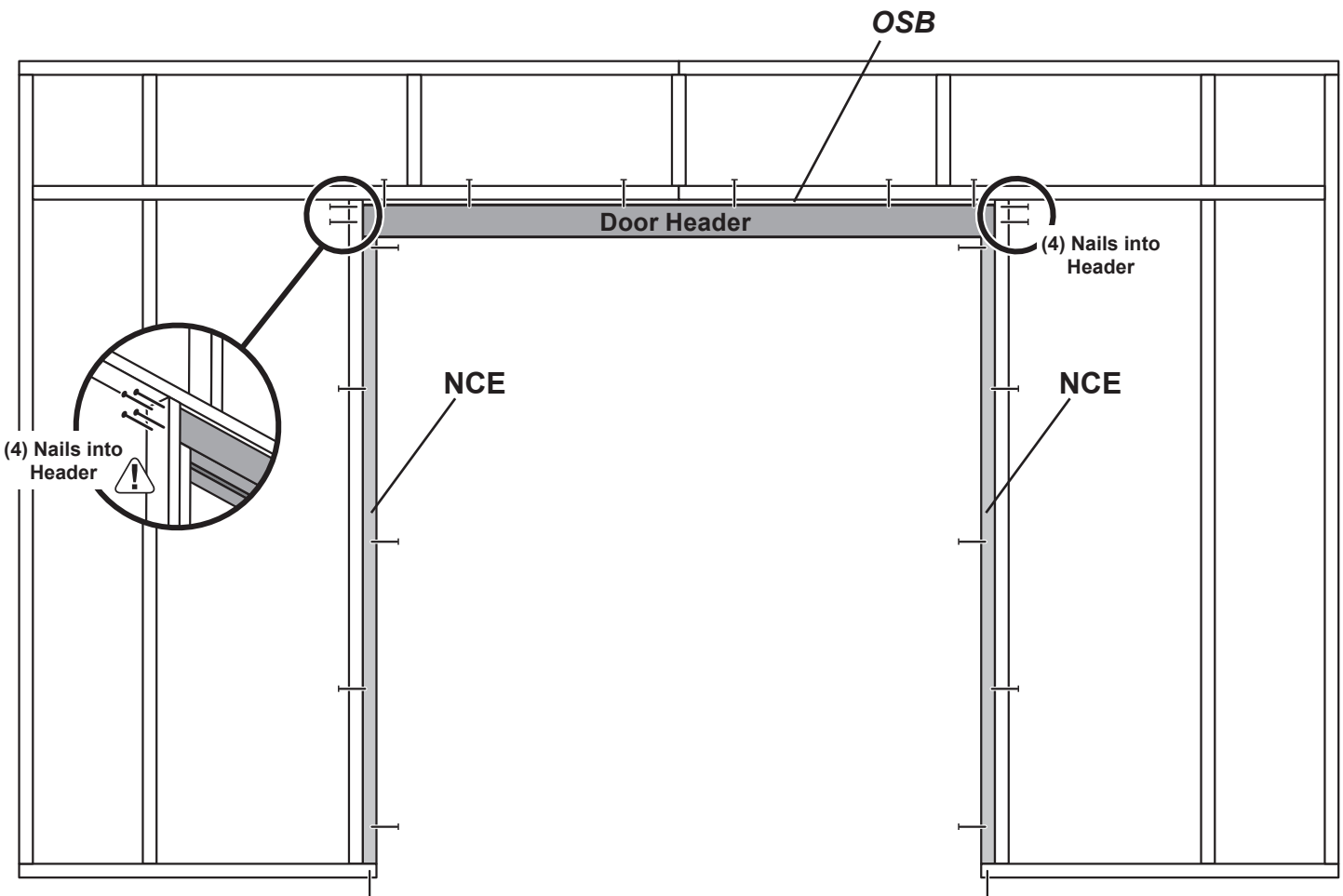

Your front wall frame is now complete.

FRONT WALL PANELS

PARTS REQUIRED:

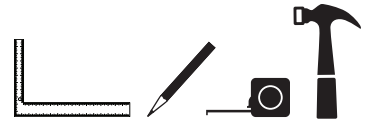
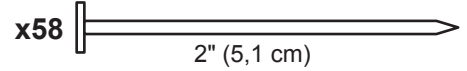
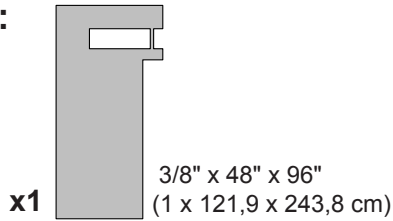

Install all panels with the primed side facing up.

Handle panels with care to avoid breakage.

✓ **BEGIN**

- 1** Install first **48" x 96"** panel 5-7/8" above top plate.
Secure panel with 2" nails spaced 6" apart along edges and 12" apart on inside of panels.
There will be a 5-7/8" reveal at the top.

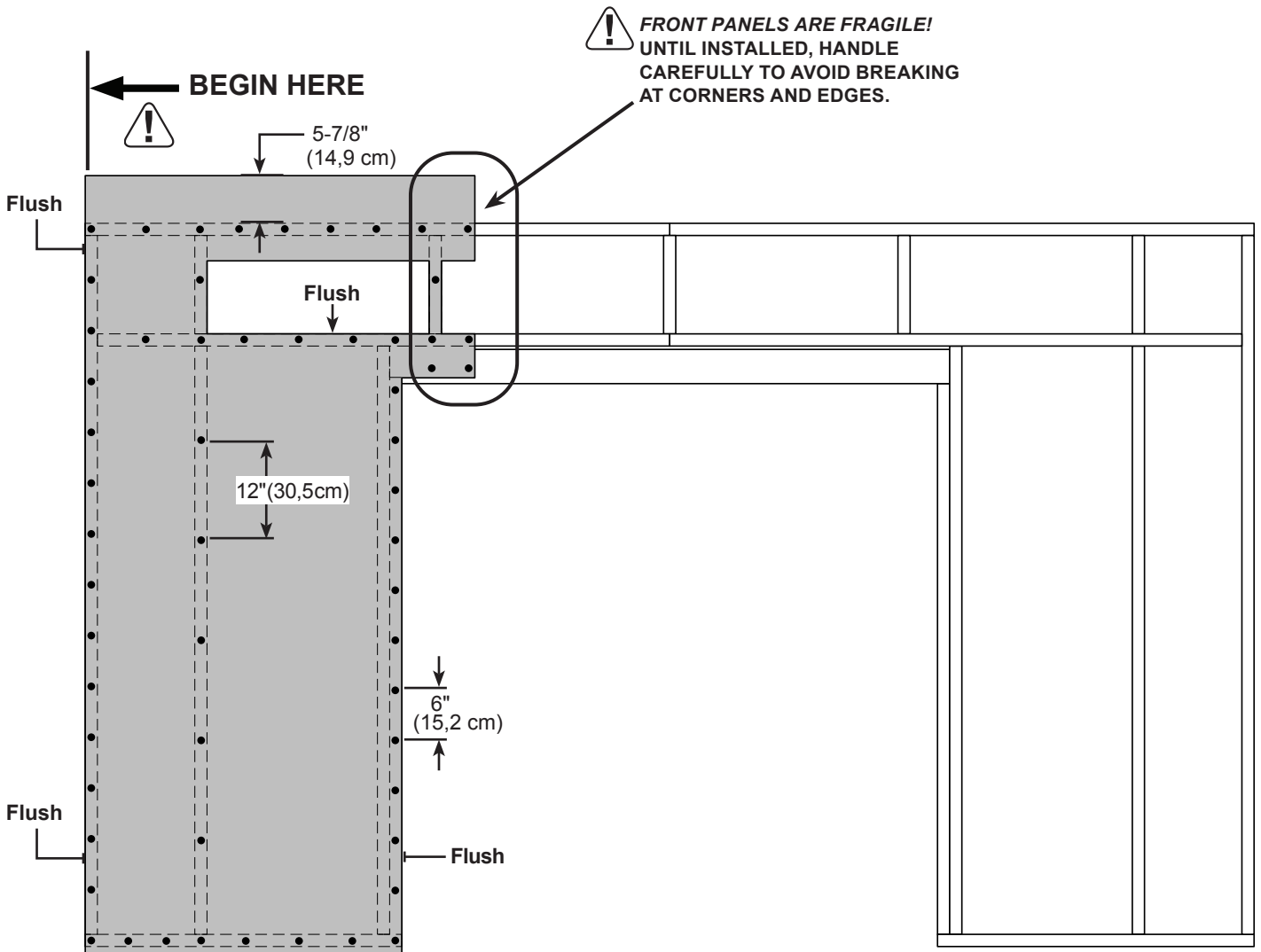

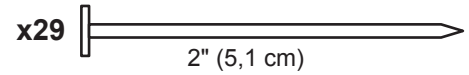

FRONT WALL PANELS

PARTS REQUIRED:



x1 
3/8" x 1-1/2" x 9"
(1 x 3,8 x 22,9 cm)

x1 
3/8" x 4-1/2" x 48"
(1 x 11,4 x 121,9 cm)

x1 
3/8" x 10-7/16" x 48"
(1 x 26,5 x 121,9 cm)

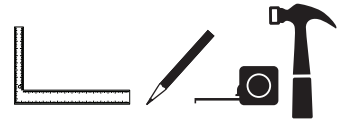

2 Install panels in the following order:

1. 10-7/16" x 48"
2. 1-1/2" x 9"
3. 4-1/2" x 48"

Secure panels with 2" nails spaced 6" apart.

There will be a 5-7/8" reveal at the top of upper panel.

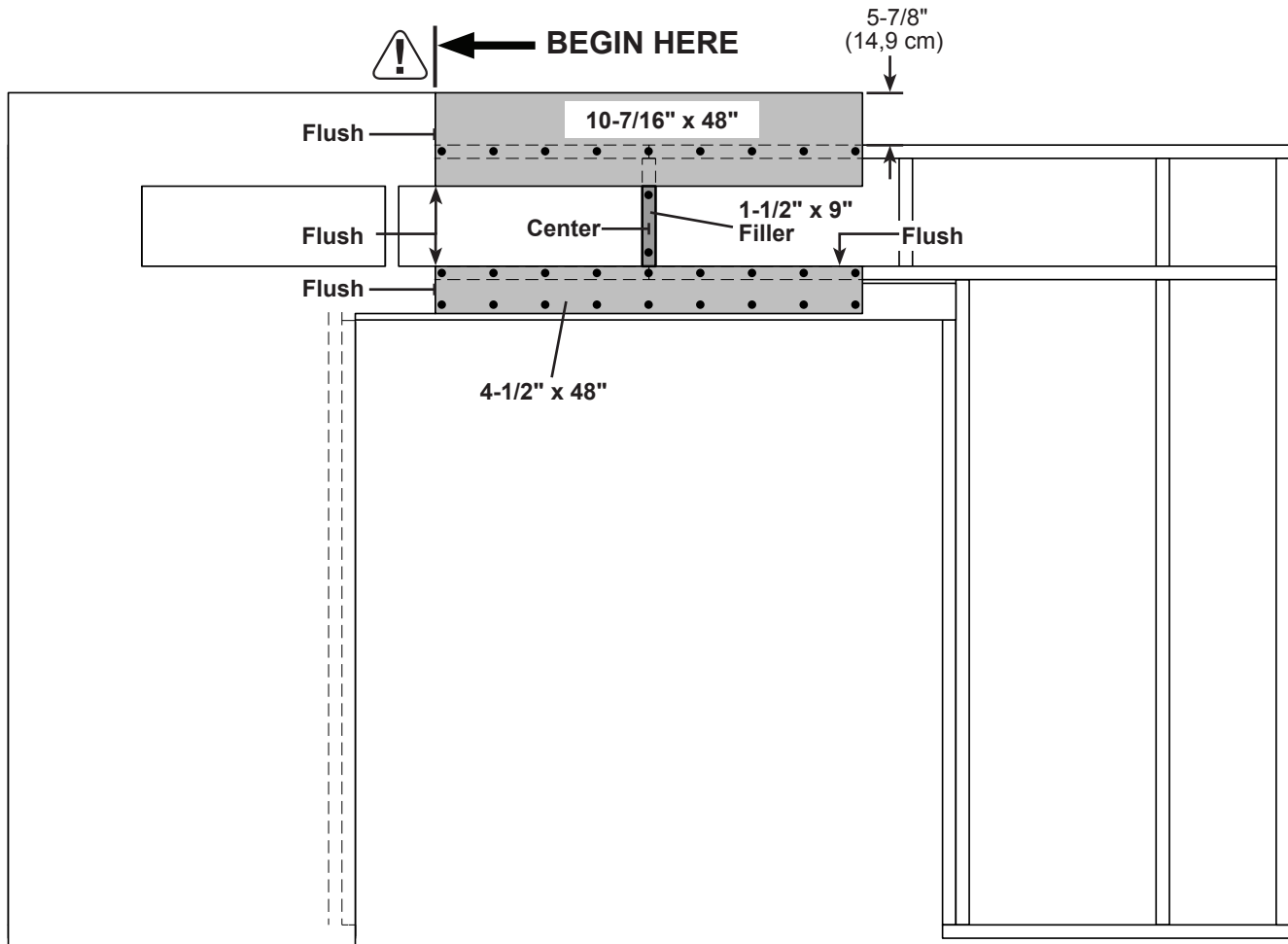

FRONT WALL PANELS

PARTS REQUIRED:

x1 **OY** Temporary Brace
2 x 3 x 72" (5,1 x 7,6 x 182,8 cm)

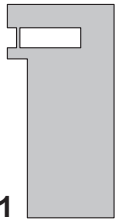
x1  3/8" x 48" x 96"
(1 x 121,9 x 243,8 cm)

x2  3" (7,6 cm)

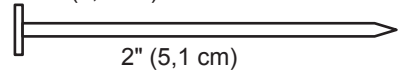
x58  2" (5,1 cm)



4 Install 2nd **48" x 96"** panel flush to frame as shown and 5-7/8" from the top.
Secure panel with 2" nails spaced 6" apart along edges and 12" apart on inside of panels.

5 Install **OY** as a temporary brace to maintain 64" (162,6 cm) between studs.
Secure with (2) 3" screws.

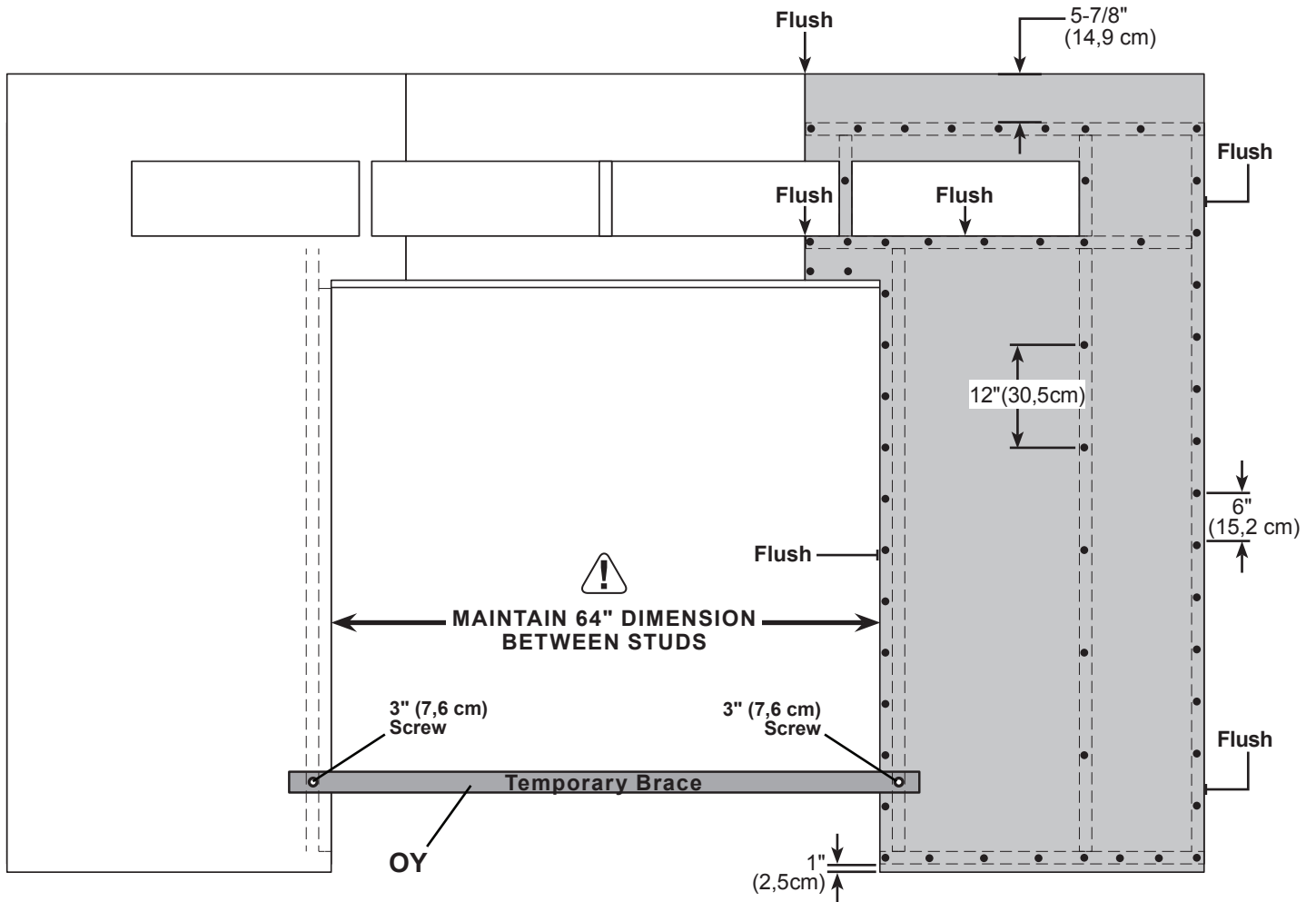

Your front wall is now assembled.
Carefully flip the front wall over.

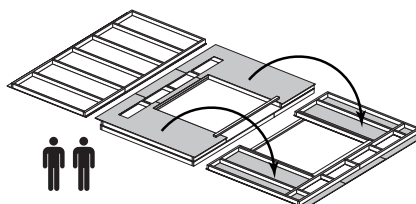

BACK WALL INSTALLATION

PARTS REQUIRED:

x1 **GKA** **TEMPORARY**
2 x 3 x 59-1/4" (5,1 x 7,6 x 150,5 cm)



x2 3" (7,6 cm)
x12 3" (7,6 cm)
x27 2" (5,1 cm)

✓ BEGIN

1 Center back wall assembly on the 144" floor dimension.

Note: The 4" wall overhang is installed to the top.

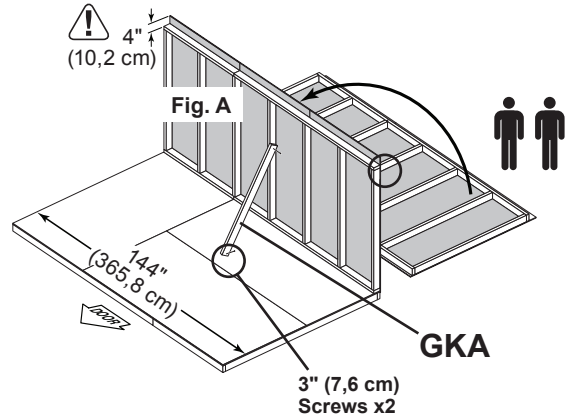

2 Use GKA as a temporary brace.

Secure GKA with (2) 3" screws (Fig. A).

3 First, nail lower edge of panel to floor frame with 2" nails spaced 6" apart.

Angle nail to hit floor frame (Fig. B).

4 Secure back wall bottom plate to floor with 3" nails (Fig. B).

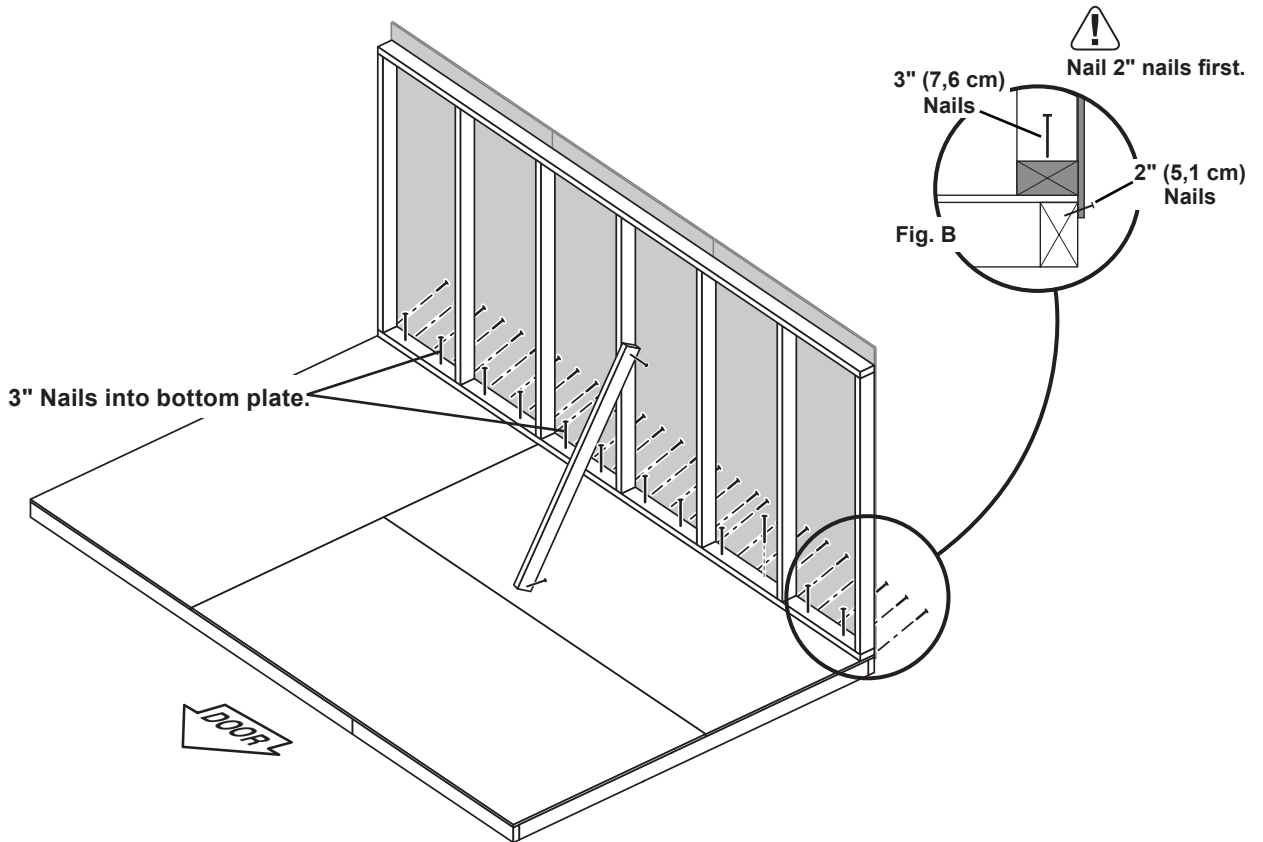

Your back wall is now standing.

FRONT WALL INSTALLATION

PARTS REQUIRED

x2 **OFB** **TEMPORARY**
 2 x 4 x 78-1/16" (5,1 x 10,2 x 198,3 cm)

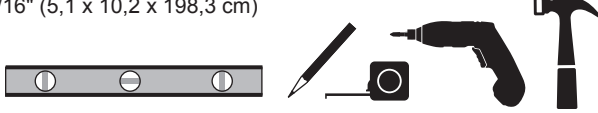

x4 3" (7,6 cm)

x8 3" (7,6 cm)

x14 2" (5,1 cm)

✓ BEGIN

1 Center front wall assembly on the 144" front floor dimension.

2 Use (2) **OFB** as temporary braces.
 Level wall and secure **OFB** with 3" screws.

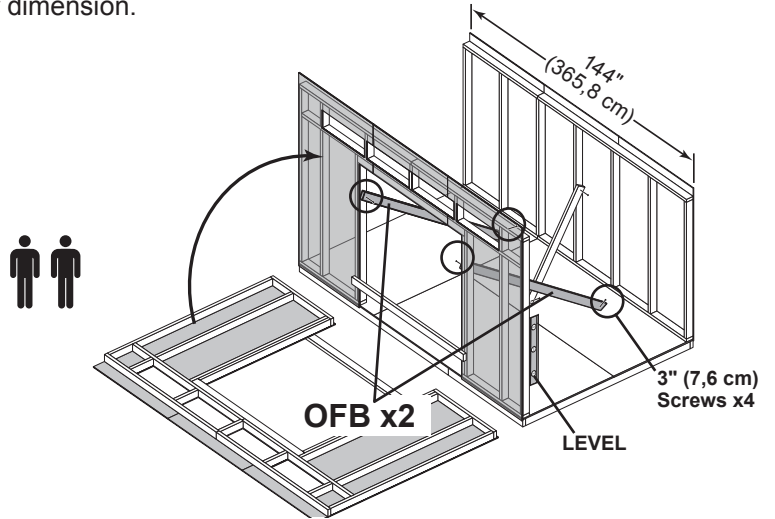

3 Secure lower edge of panel to floor frame with 2" nails spaced 6" apart.
 Angle nail to hit floor frame (**Fig. A**).
 Secure wall bottom plates to floor with 3" nails (**Fig. A**).

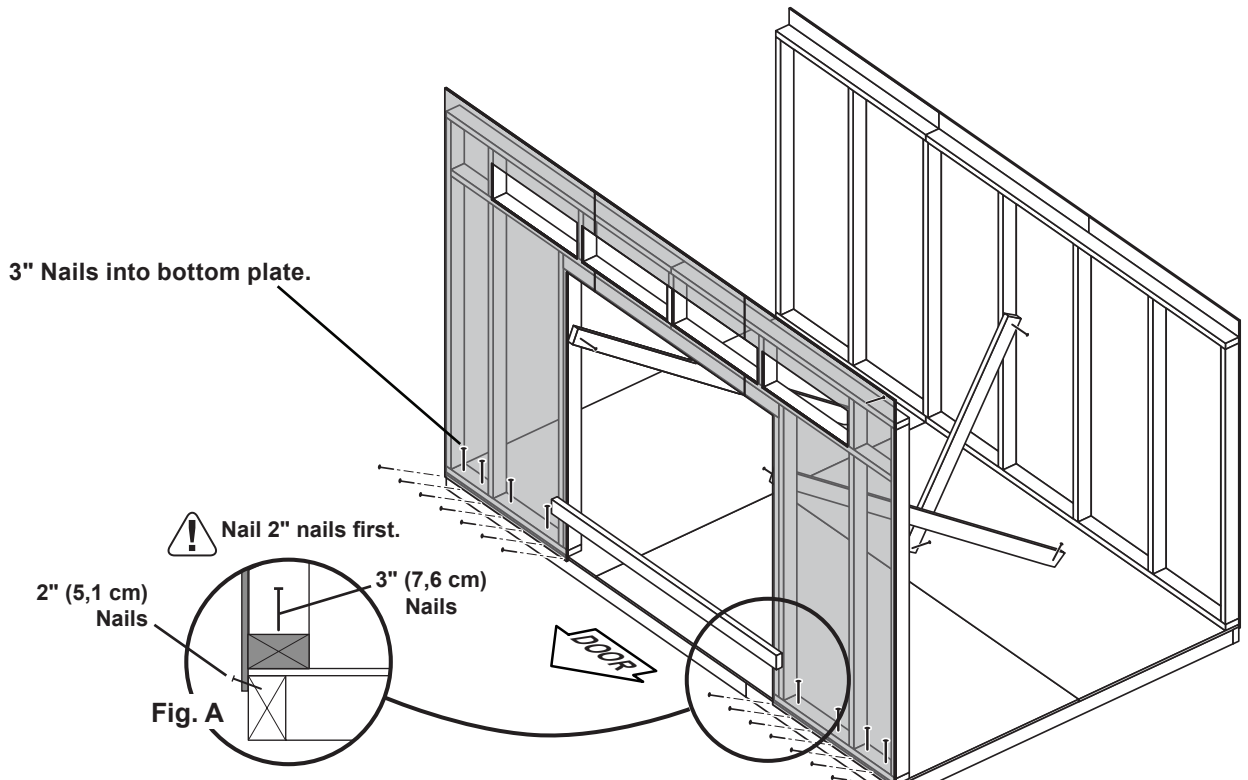

Your front wall is now standing.

DOUBLER INSTALLATION

PARTS REQUIRED:

x2 **SP**
2 x 4 x 48" (5,1 x 10,2 x 122 cm)

x2 **TP**
2 x 4 x 96" (5,1 x 10,2 x 243,8 cm)

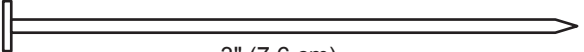
x32  3" (7,6 cm)



✓ BEGIN

- 1 Center doublers **SP** and **TP** on back wall top plate.
Secure with 3" nails evenly spaced.

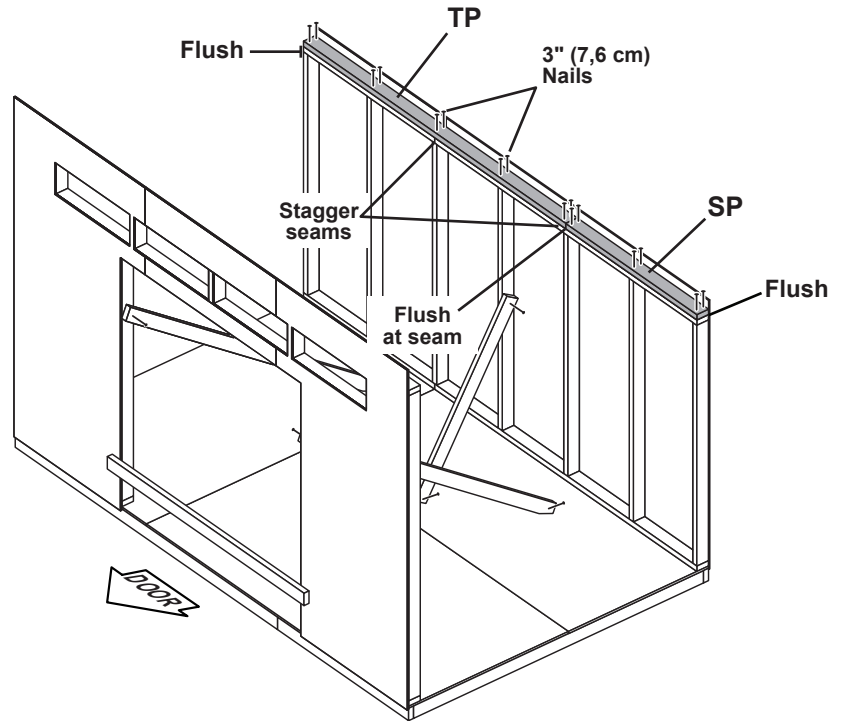

- 2 Center doublers **SP** and **TP** on front wall top plate.
Secure with 3" nails evenly spaced.

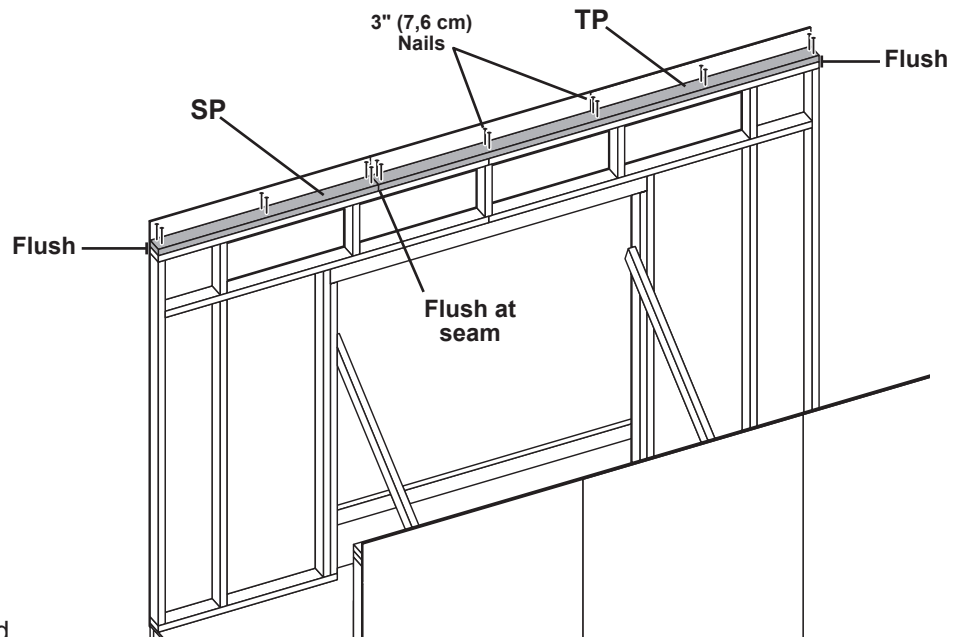

Your doublers are now installed.

OUTER RAFTER INSTALLATION

PARTS REQUIRED:

x2 **SDC**
2 x 4 x 92-3/16" (5,1 x 10,2 x 234,2 cm)

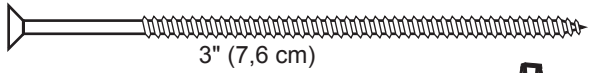
x4  3" (7,6 cm)

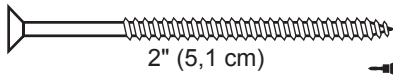
x4  2" (5,1 cm)



✓ BEGIN

- 1 Install rafters on front and back wall doublers.
Ensure rafters are flush to end of top plates (**Fig. B, Fig. D**).
Secure rafters as shown in all Figures.

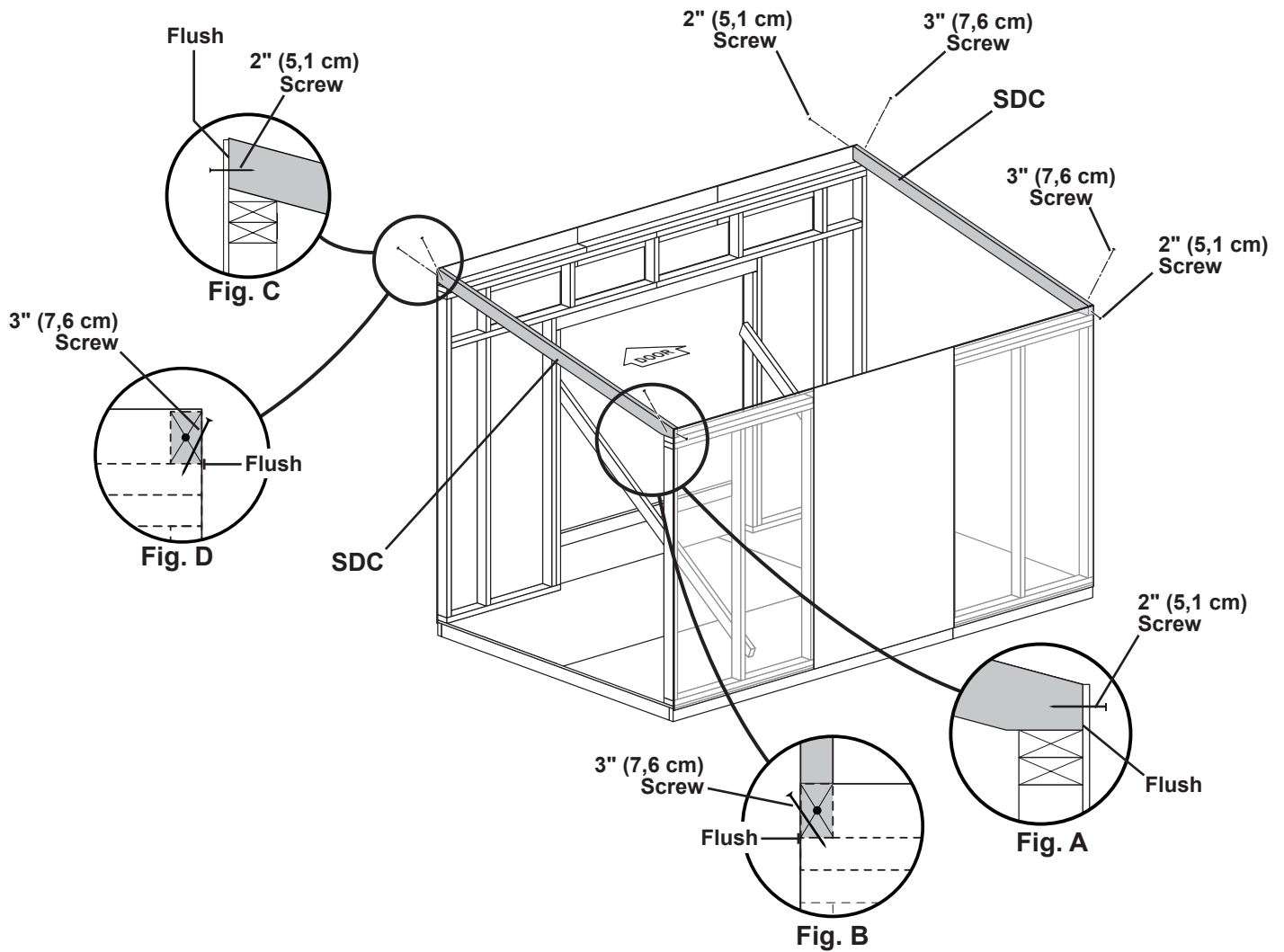

OUTER RAFTER INSTALLATION

PARTS REQUIRED:

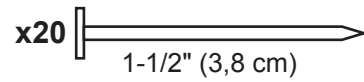
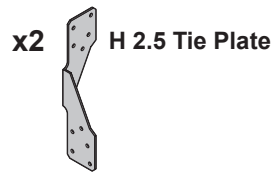

- Secure (2) tie plates with 1-1/2" nails, as shown.

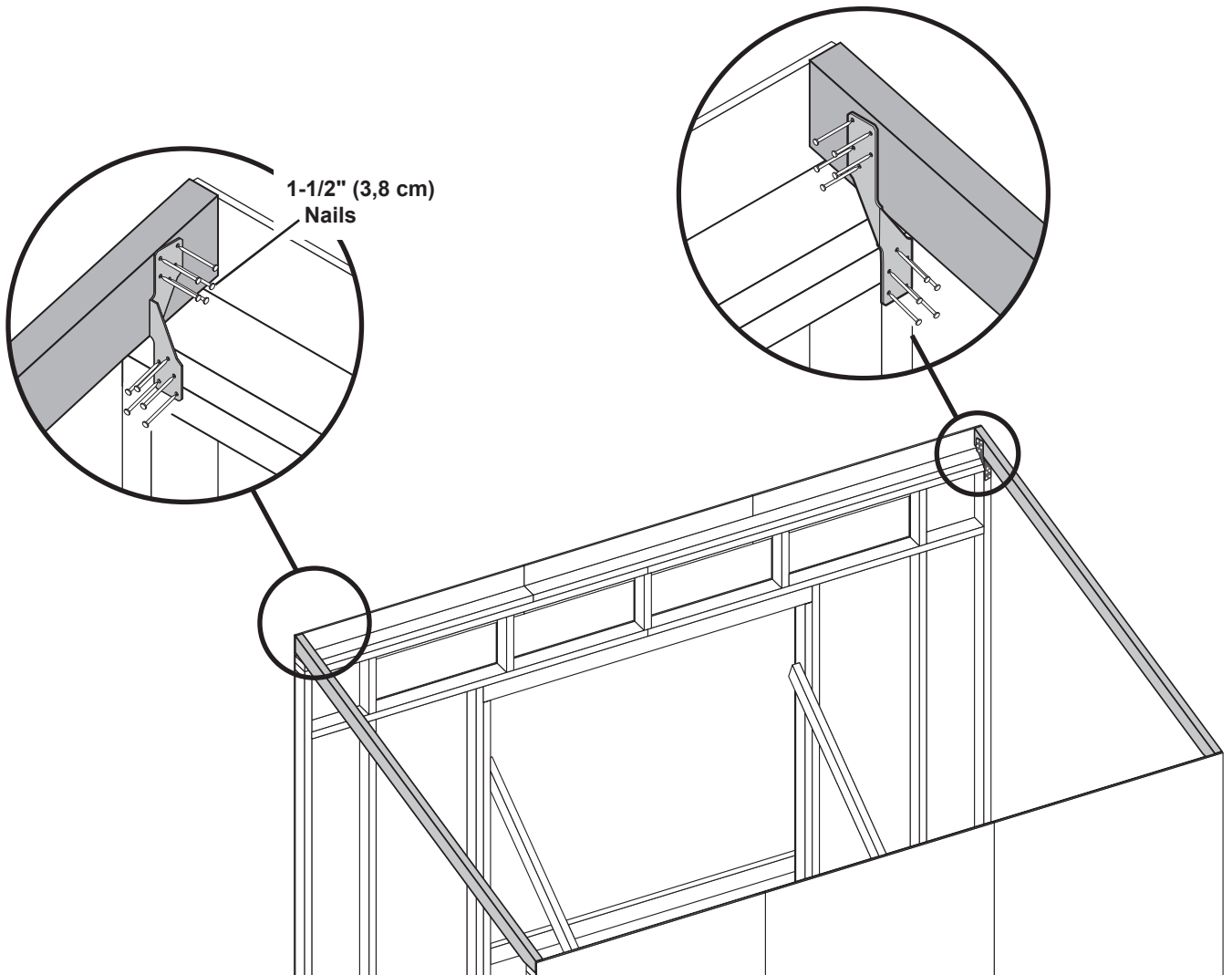

Your outer rafters are now installed.

RAFTERS

PARTS REQUIRED:

x9 **SDC**
2 x 4 x 92-3/16" (5,1 x 10,2 x 234,2 cm)

x36  3" (7,6 cm)

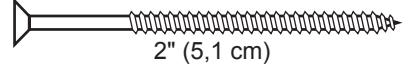

x18  2" (5,1 cm)

✓ **BEGIN**

- 1 Measure and mark location of each rafter. **Note the door location.**
- 2 Center rafters on marks. Secure rafters with 2" screws installed centered into outer rafter ends (**Fig. A**).
Continue securing rafters with 3" screws toe-screwed into doublers (**Fig. B**).

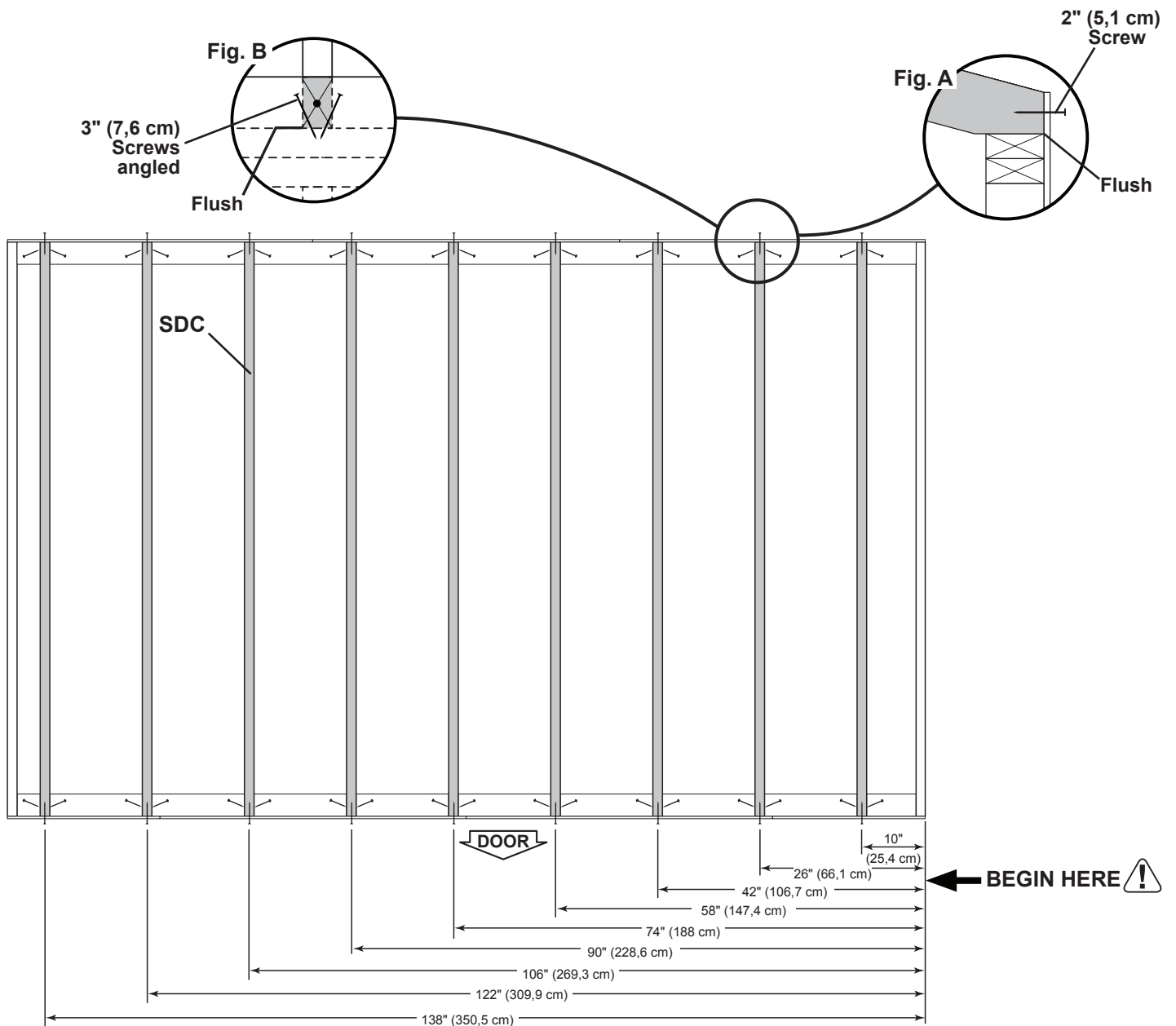

RAFTERS

PARTS REQUIRED:

x9



H 2.5 Tie Plate

x90

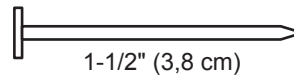

1-1/2" (3,8 cm)



- 3 Install (9) tie plates, as shown (Fig. A).
Secure with with 1-1/2" nails.

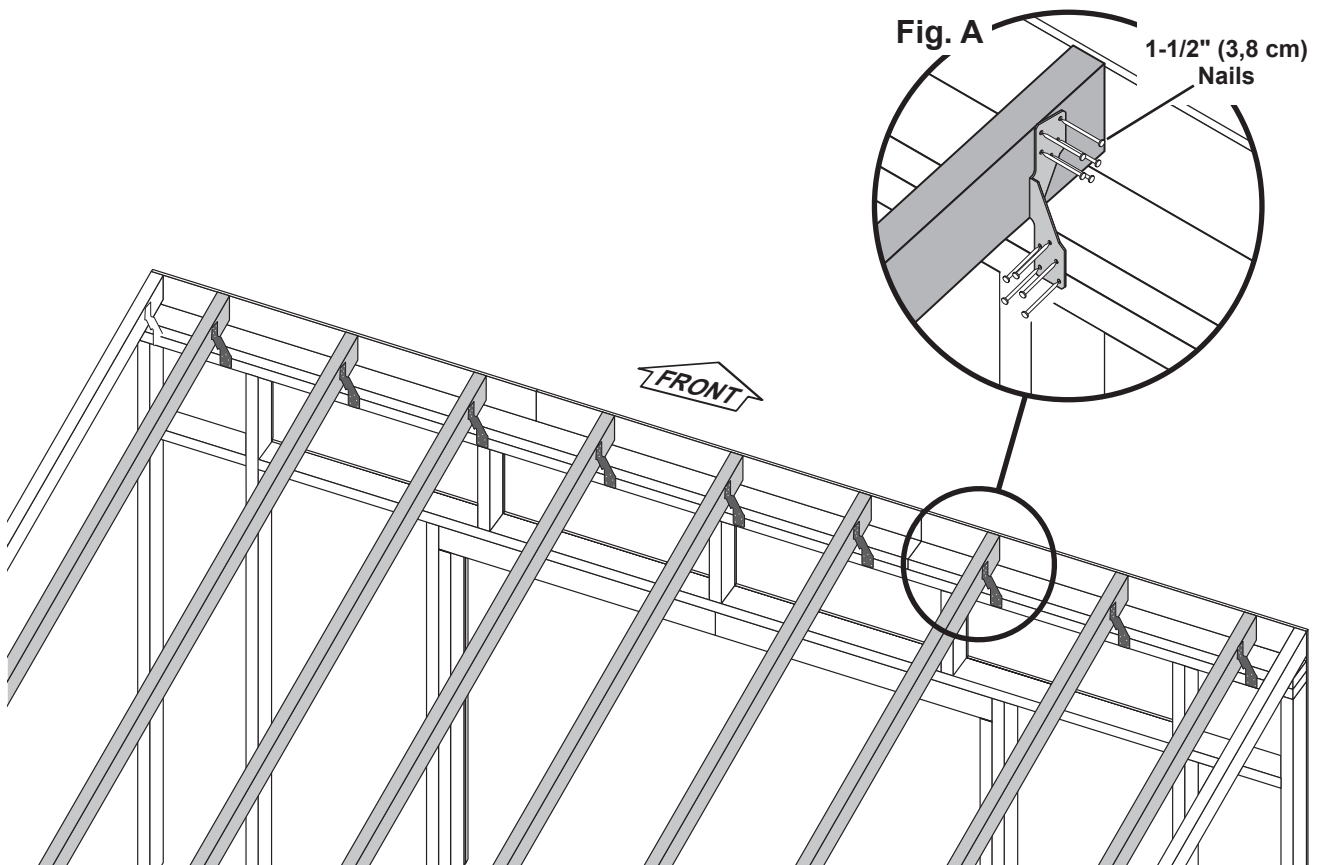

Your rafters are now installed.

SIDE WALL PANELS

PARTS REQUIRED:

x1 **OO** TEMPORARY SUPPORT
69" (75,3 cm) Door Stiffener

x2 3" (7,6 cm)

x2 2" (5,1 cm)

x1 1-1/2" (3,8 cm)

x1 3/8" x 42" x 96"
(1 x 106,7 x 243,8 cm)

x1 3/8" x 42" x 96"
(1 x 106,7 x 243,8 cm)

x1 3/8" x 48" x 84"
(1 x 121,9 x 213,4 cm)

x1 3/8" x 48" x 84"
(1 x 121,9 x 213,4 cm)

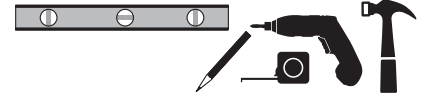

Install all panels with the primed side facing out.

✓ BEGIN

- Center and fasten **OO** as a temporary support. Measure down from floor 1" and mark. Secure to floor joist with (2) 3" screws.

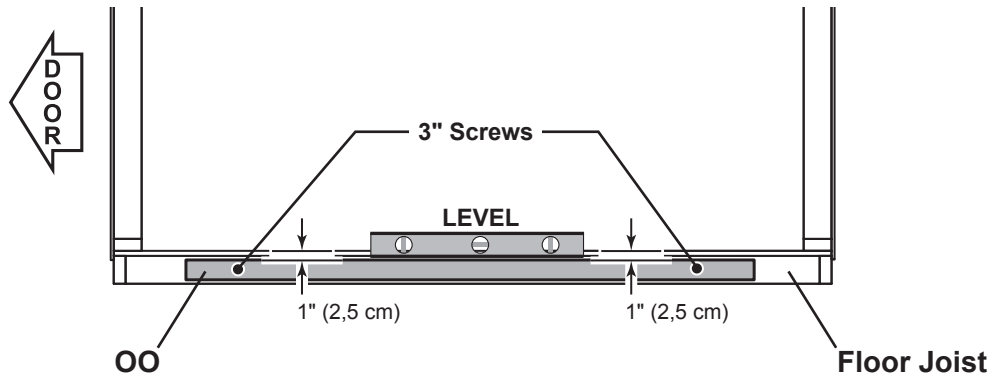

- Place 42" x 96" front panel on temporary brace **OO** and flush with front wall stud (**Fig. B**). Secure panel with (2) 2" nails in the bottom corners (**Fig. A**). Angle nails to hit floor frame (**Fig. C**).
- Push the front and/or back wall until front and side wall panels are flush along the corner (**Fig. B, Fig. D**). Secure upper corner with (1) 1-1/2" nail into rafter.

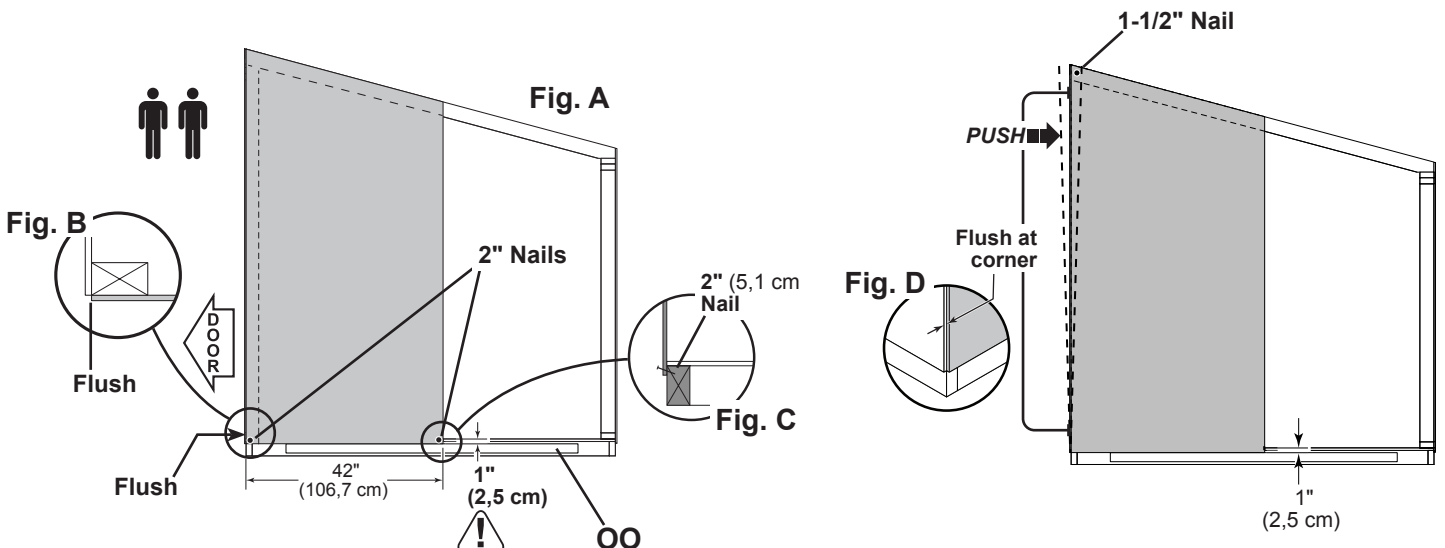

SIDE WALL PANELS

PARTS REQUIRED:

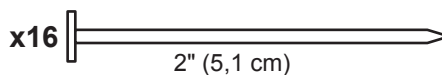
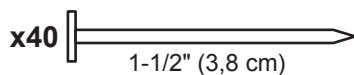

- 4** Place 48" x 84" panel on side wall flush with bottom of installed 42" x 96" panel. Secure panel with (1) 2" nail in bottom corner (**Fig. C**). Ensure the measurement between the panel edges are the same along the corner (**Fig. F**). Secure panel with (1) 1-1/2" nail in upper corner.

Remove temporary support **OO**.

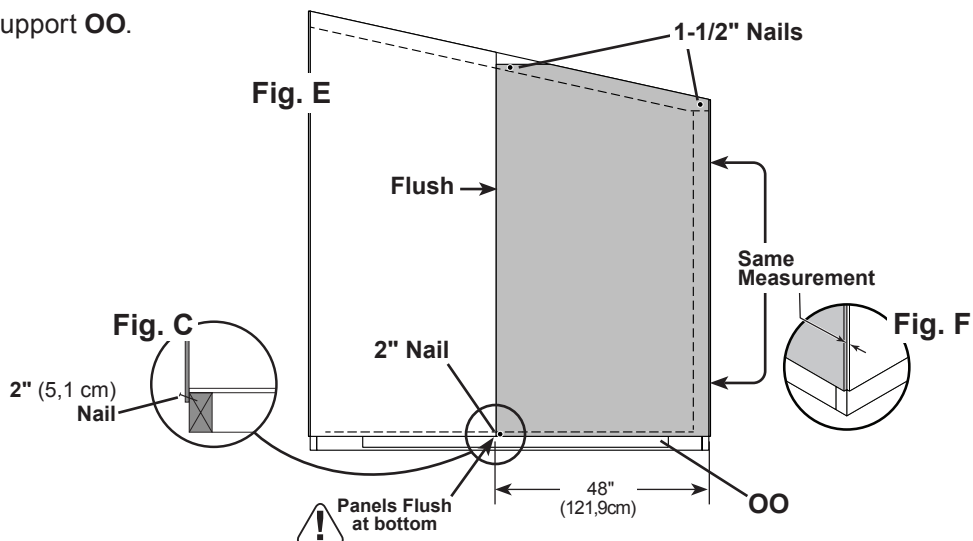

- 5** Secure lower edge of panels to floor with 2" nails spaced 6" apart. Angle nails to hit floor frame (**Fig. G**). Secure side wall panels to rafter and wall studs with 1-1/2" nails spaced 6" apart as shown.

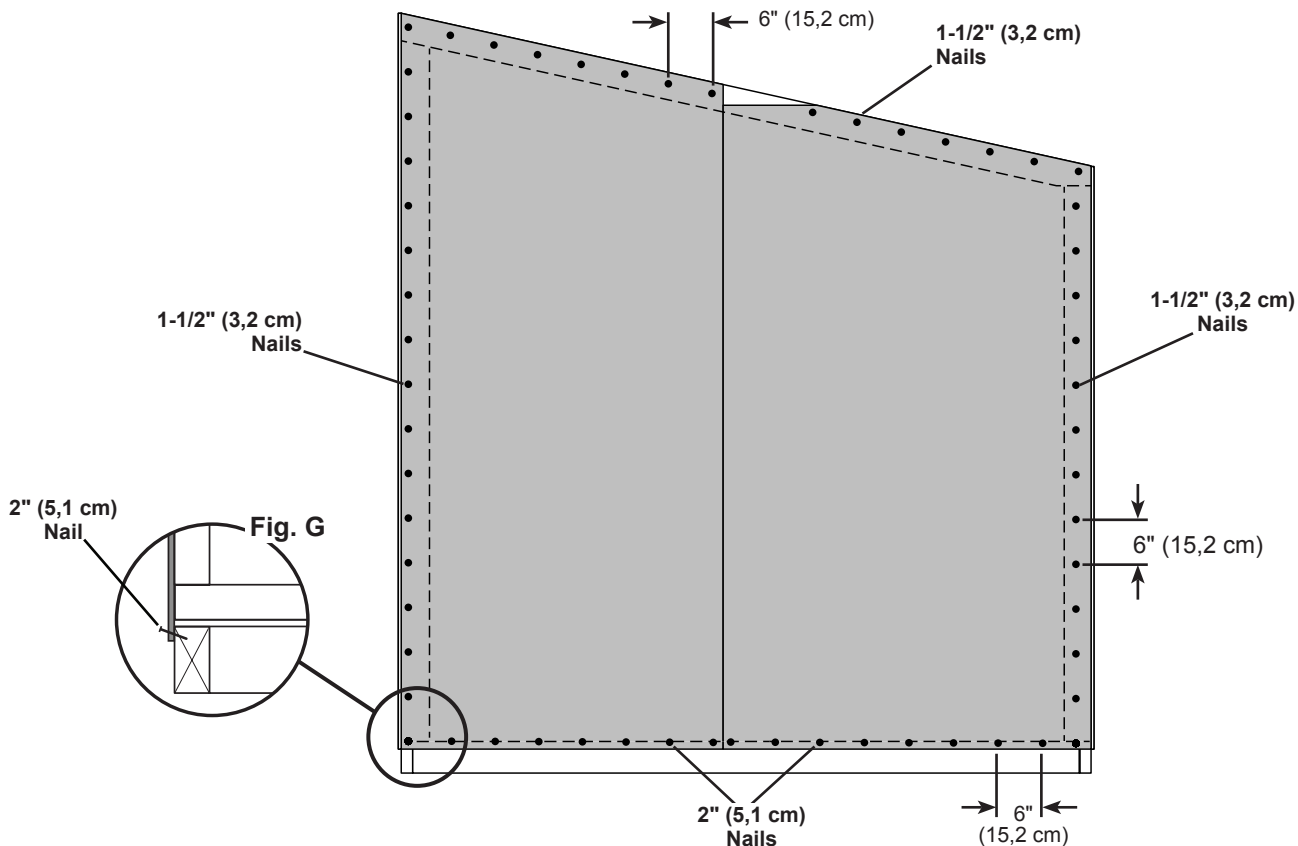

Repeat steps to install the opposite side wall panels.

SIDE WALL STUDS

PARTS REQUIRED:

x2 **OFB**
2 x 4 x 78-1/16" (5,1 x 10,2 x 198,3 cm)

x2 **NES**
2 x 4 x 82-1/2" (5,1 x 10,2 x 209,6 cm)

x2 **KTB**
2 x 4 x 86-15/16" (5,1 x 10,2 x 220,8 cm)

x18  3" (7,6 cm)

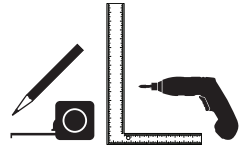

✓ **BEGIN**

- 1 Install **NES** centered at seam of side wall panels (**Fig A**).
Use a square to ensure 90 degree squareness of studs (**KTB**, **NES** and **OFB**).

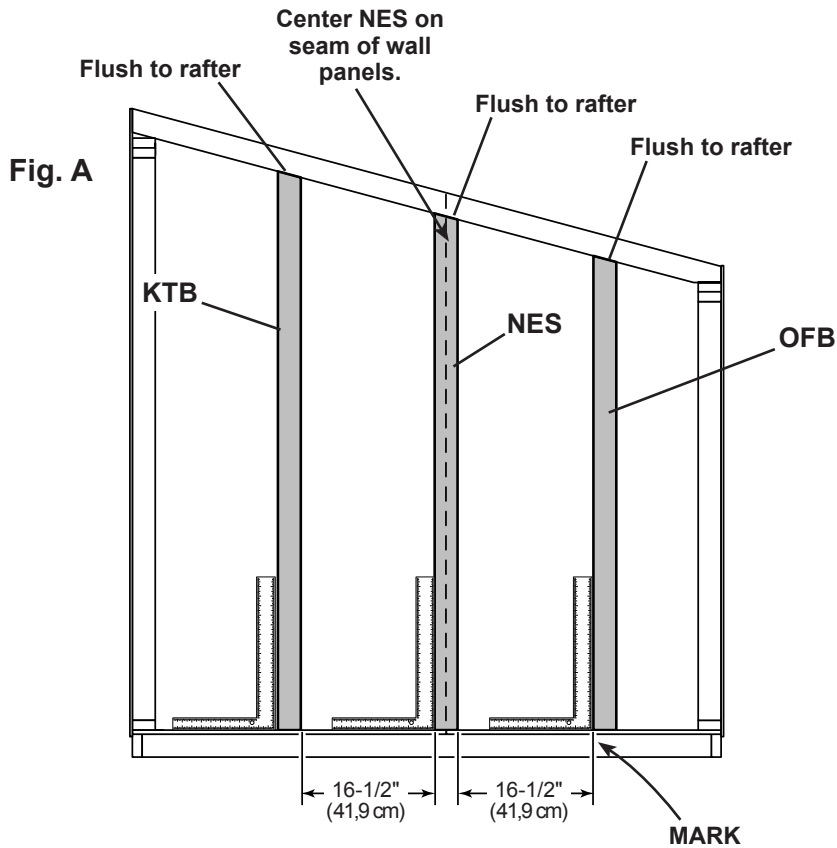

- 2 Mark locations of studs and ensure studs are at 90 degree angle to floor and flush to end rafter.
Secure studs with 3" screws into rafter and floor frame (**Fig B**).

Repeat steps to install the opposite side wall studs.

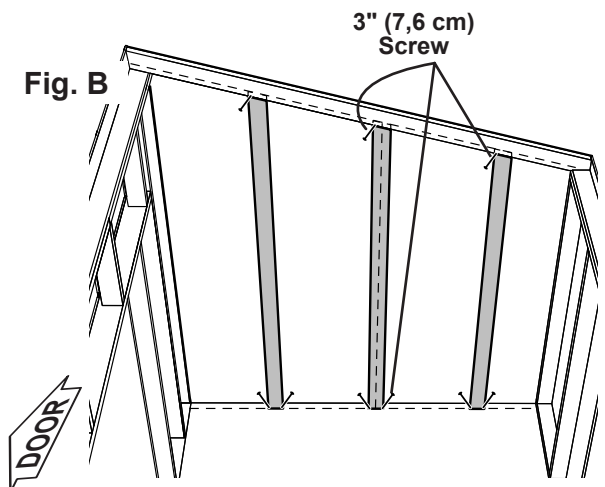

SIDE WALL PANELS

PARTS REQUIRED:

x1 *(Left / Green)*
 $\frac{3}{8}'' \times 2\text{-}11/16'' \times 12\text{-}1/4''$ (1,5 x 6,8 x 31,1 cm)

x1 *(Right / Red)*
 $\frac{3}{8}'' \times 2\text{-}11/16'' \times 12\text{-}1/4''$ (1,5 x 6,8 x 31,1 cm)

x90 $1\text{-}1/2''$ (3,8 cm)

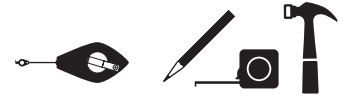

BEGIN

- 1 Install **2-11/16" x 12-1/4"** triangular filler panel using (2) 1-1/2" nails.
 Flush filler panel to installed panels (*Red for right side*) as shown.
- 2 Measure and mark location of studs 20" from center of panel seam as shown.
 Secure side wall panels to inside wall studs with 1-1/2" nails 6" apart along panel seam and 12" apart in middle of panels.

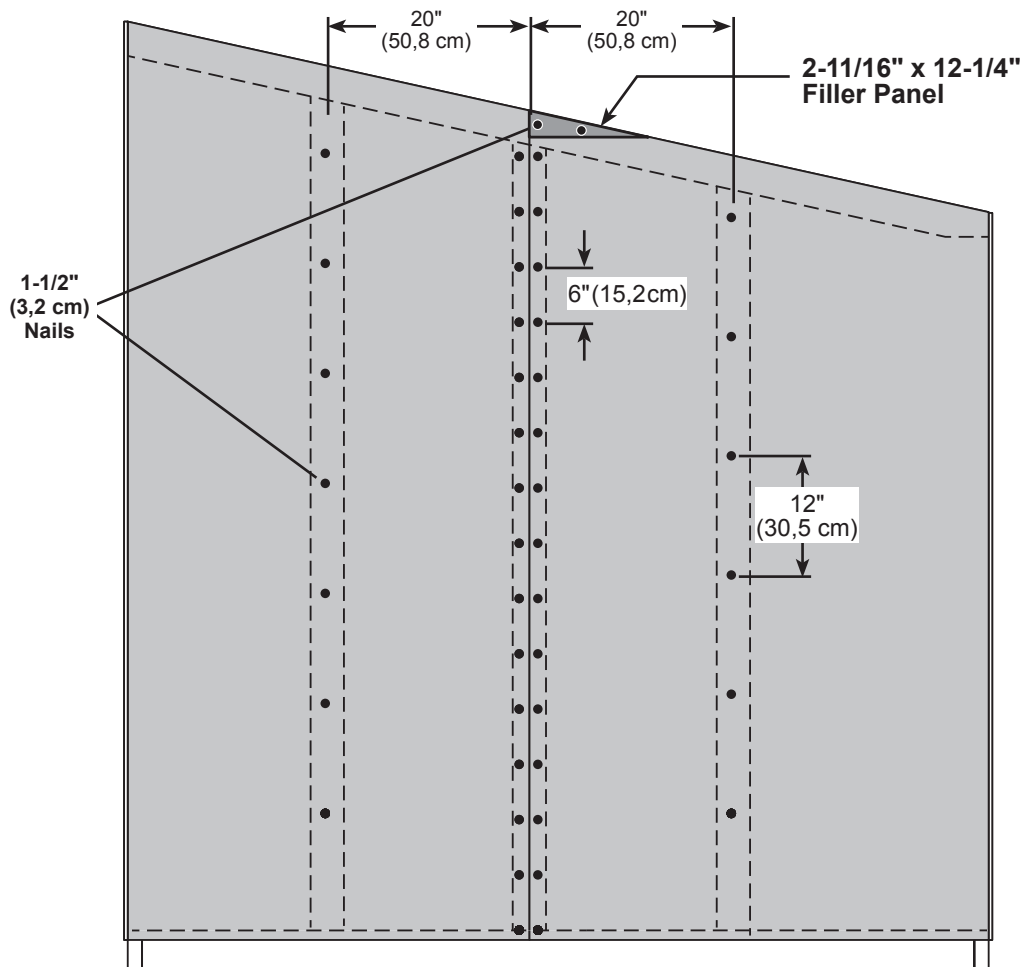

Repeat steps to secure the opposite side wall panels.





Your side walls are now completed.

ROOF PANELS

PARTS REQUIRED:

x1  7/16 x 10-11/16 x 28"
(1,1 x 27,1 x 71,1 cm)

x1  7/16 x 10-11/16 x 96"
(1,1 x 27,1 x 243,8 cm)

x1  7/16 x 10-11/16 x 31-7/8"
(1,1 x 27,1 x 81 cm)

x26
 3/4" GAUGE BLOCK

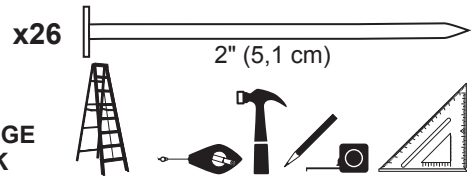

Install all roof panels with the rough side facing up.

 Roof panels may cause serious injury until securely fastened.



 BEGIN

- 1 Measure 7-5/8" up from rafter ends and snap a chalk line (Fig. A).
Install the 10-11/16" x 96" lower roof panel to the chalk line.
Ensure the panel measures 3/4" on the rafter center (Fig. B).
Secure panel with 2" nails as shown.

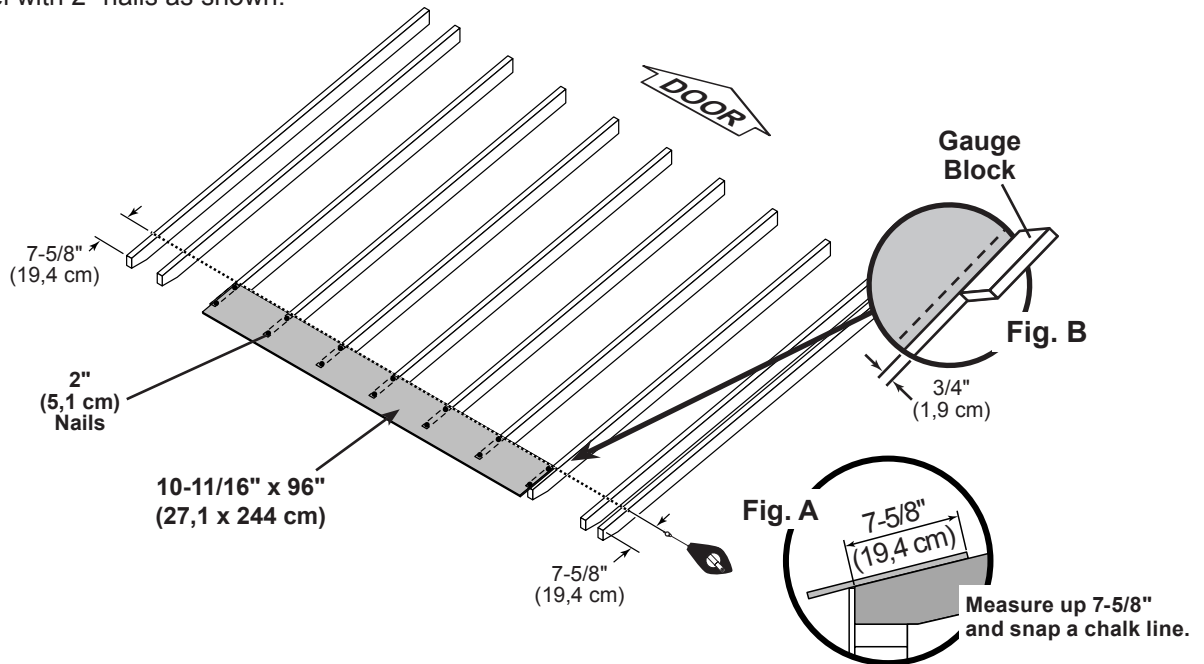

- 2 Place the 10-11/16" x 31-7/8" and 10-11/16" x 28" lower roof panels flush to the chalk line and installed panel (Fig C).
Secure panels with 2" nails as shown.

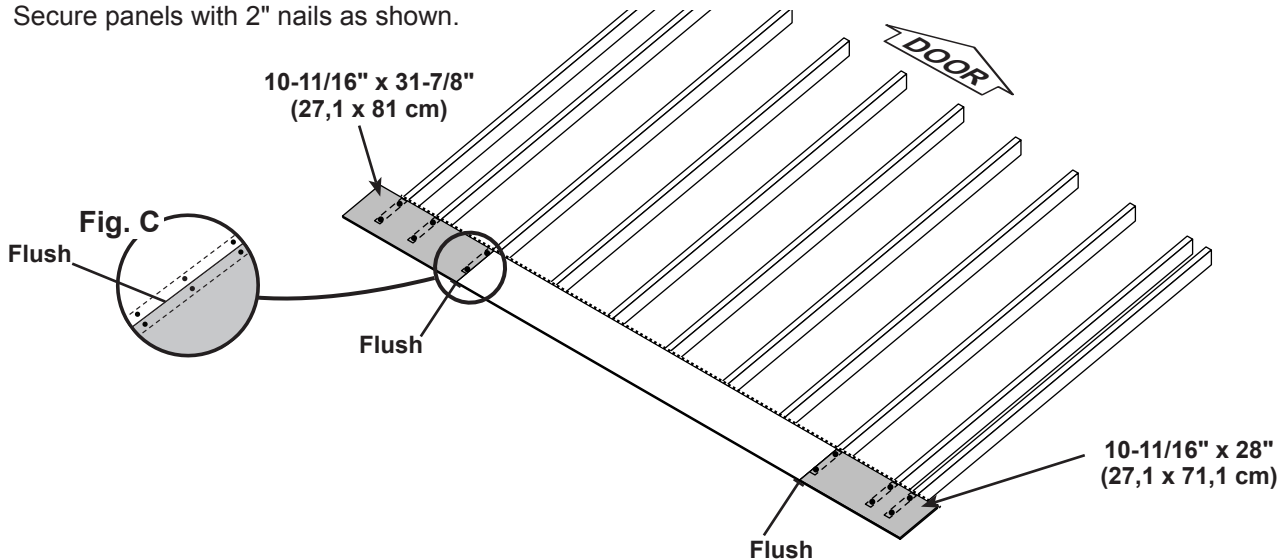

ROOF PANELS

PARTS REQUIRED:

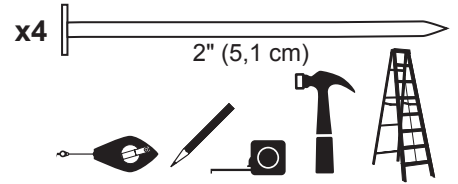
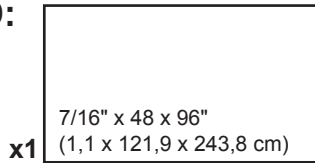

- 3** Square the roof by installing one **48" x 96"** panel at this time.
Use the panel's long edge as a lever to bring your roof into square.

Place the **48" x 96"** roof panel as shown.

Use the gauge block to maintain 3/4" at rafter center (**Fig. B**).

Panel should be flush to lower roof panels.

Secure with (1) 2" nail in each corner.

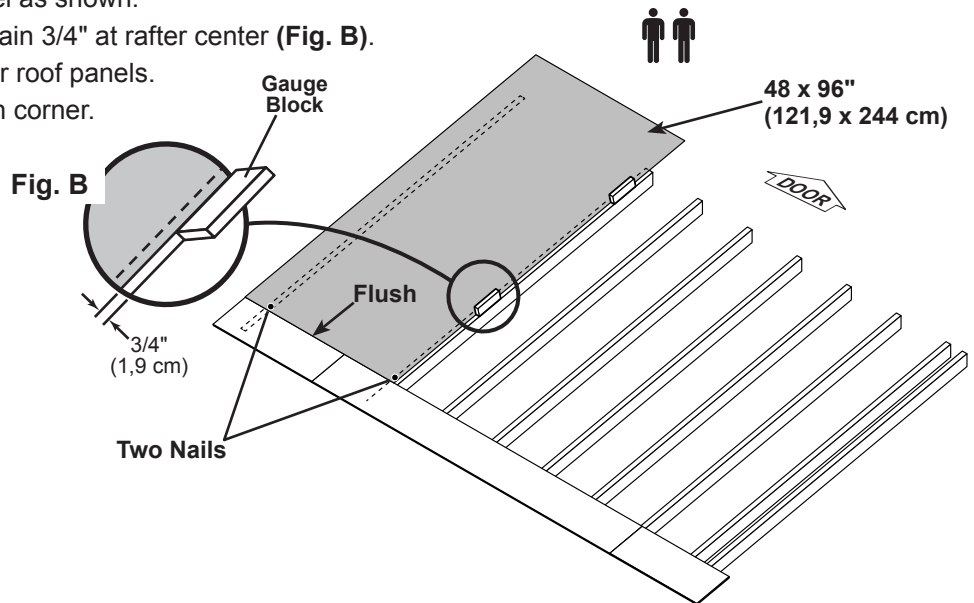

- 4** At the outside edge, use the long edge of the panel as a lever.
Move the panel side-to-side until the outside long edge is overhanging the outer rafter by 5-7/8" (**Fig E**).

Secure with (1) 2" nail in each corner.

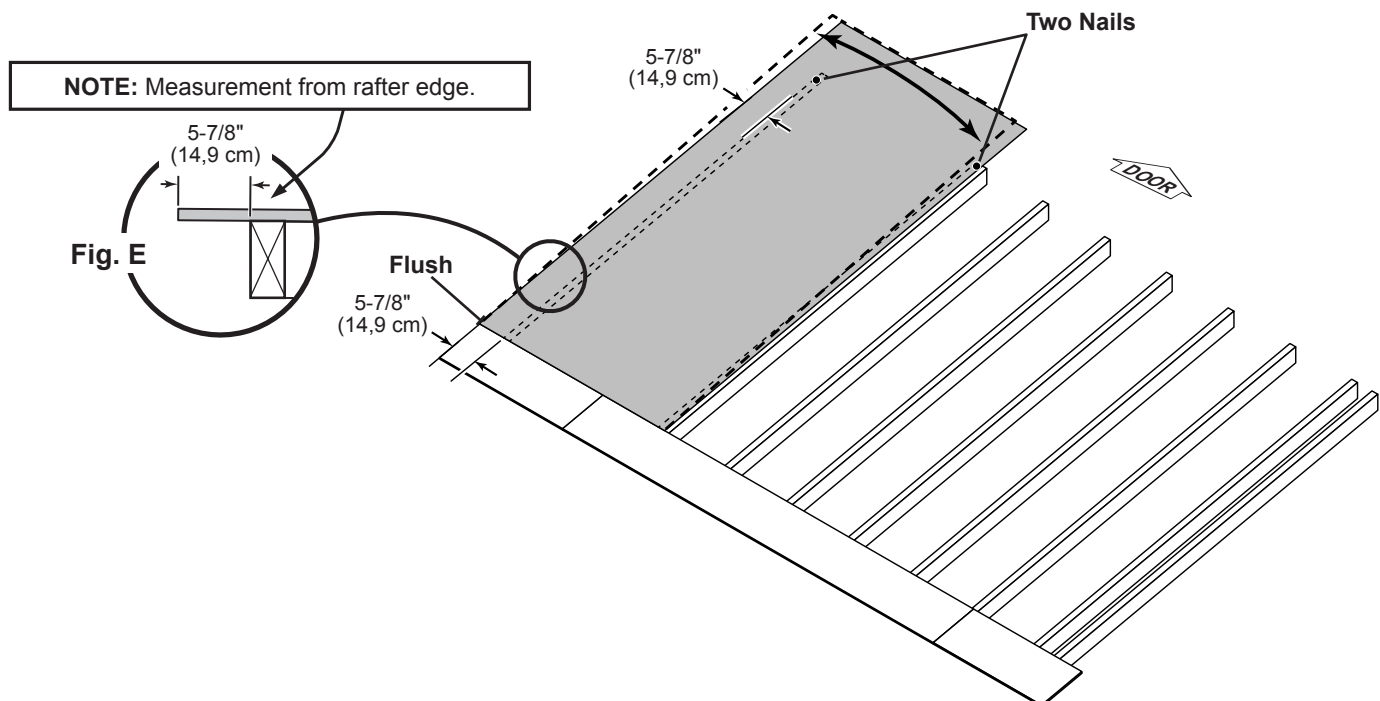

ROOF PANELS

PARTS REQUIRED:

x1



7/16" x 11-7/8" x 96"
(1,1 x 30,2 x 243,8 cm)

x2

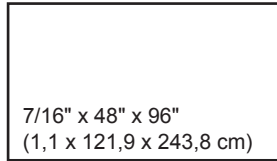

7/16" x 48" x 96"
(1,1 x 121,9 x 243,8 cm)

GAA

3/4" GAUGE
BLOCK

x12

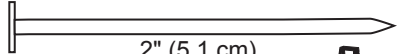

2" (5,1 cm)

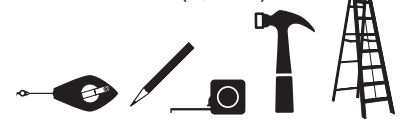

- 5** Install 2nd 48"x 96" panel flush to installed panels.

Maintain 3/4" at rafter center.

Secure panel with (1) 2" nail in each corner.

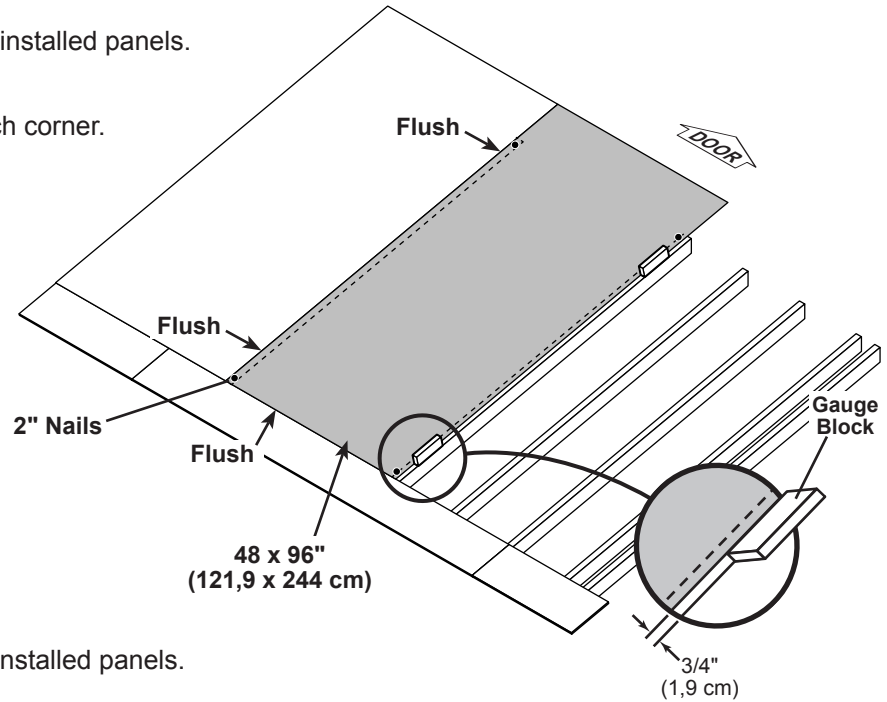

- 6** Install 3rd 48"x 96" panel flush to installed panels.

Maintain 3/4" at rafter center.

Secure panel with (1) 2" nail in each corner.

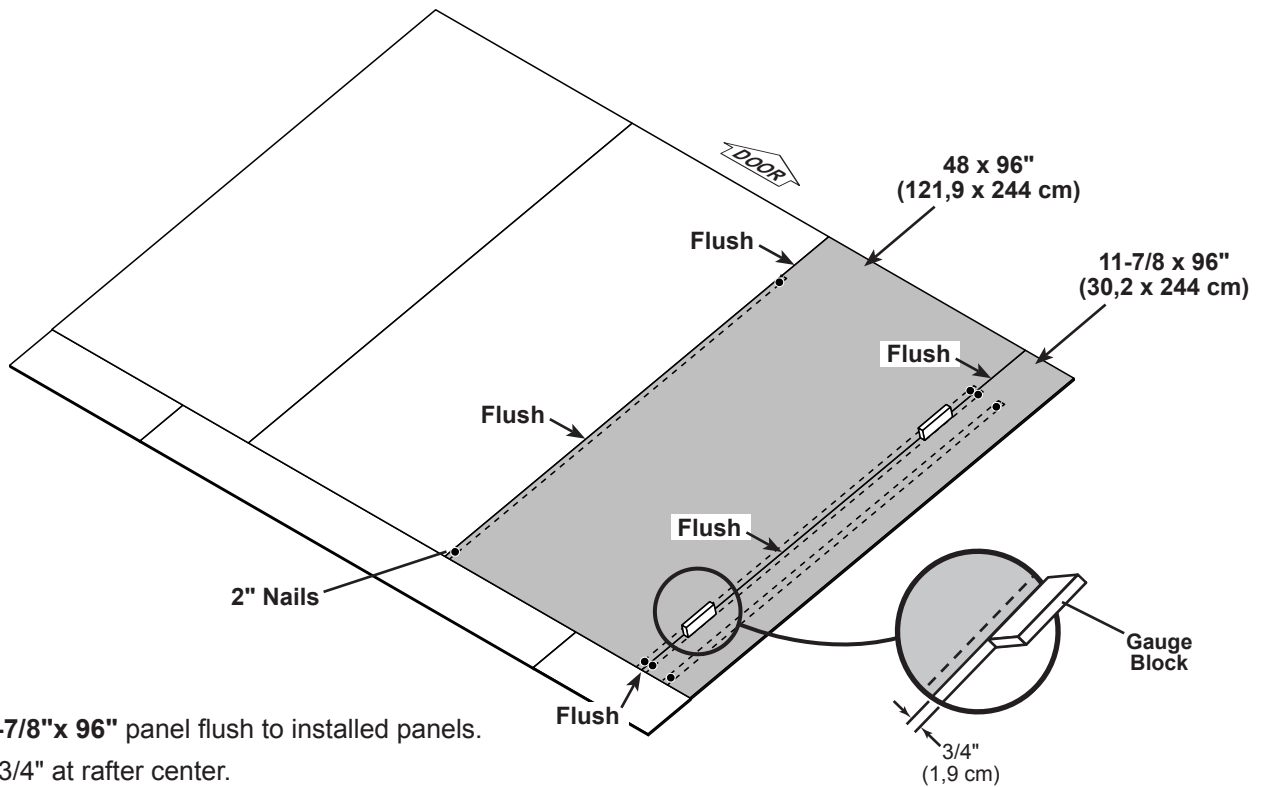

- 8** Install 11-7/8"x 96" panel flush to installed panels.

Maintain 3/4" at rafter center.

Secure panels with (1) 2" nail in each corner.

ROOF PANELS

PARTS REQUIRED:

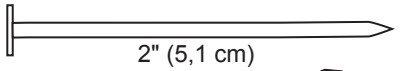
x148  2" (5,1 cm)

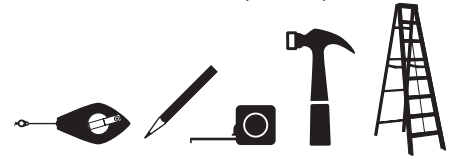

- 7 Complete the securing of all upper roof panels with 2" nails spaced 6" along edge and 12" inside panel.

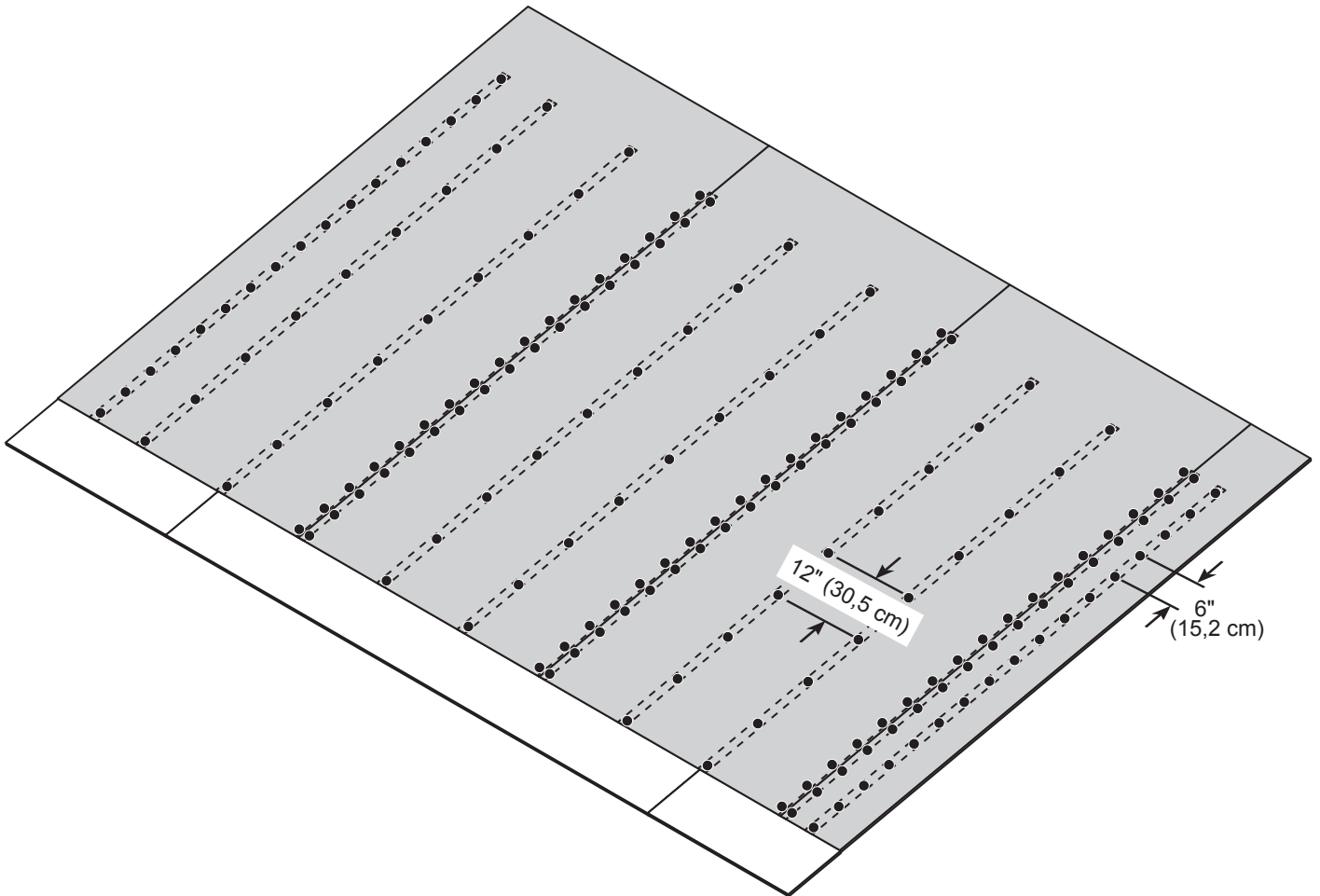

Your roof panels are now installed.

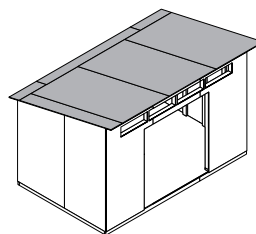

RAFTER EXTENSIONS

PARTS REQUIRED:

x11 **QVA**
2 x 3 x 10-7/16" (5,1 x 7,6 x 26,5 cm)

x28 
2" (5,1 cm)

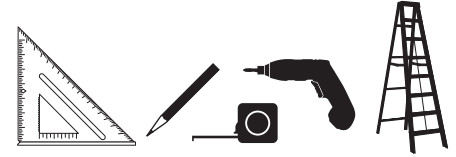

✓ BEGIN

1 Line up each rafter extension **QVA** 90° degrees square with rafters as shown.

Secure rafter extensions with 2" screws through roof panels (**Fig. A**).

Secure with (4) screws at roof panel seams.

Install **QVA** extensions flush with side wall panels (**Fig. B**).

HINT: • Use screws at rafter ends as a guide to line up **QVA** with rafter ends.

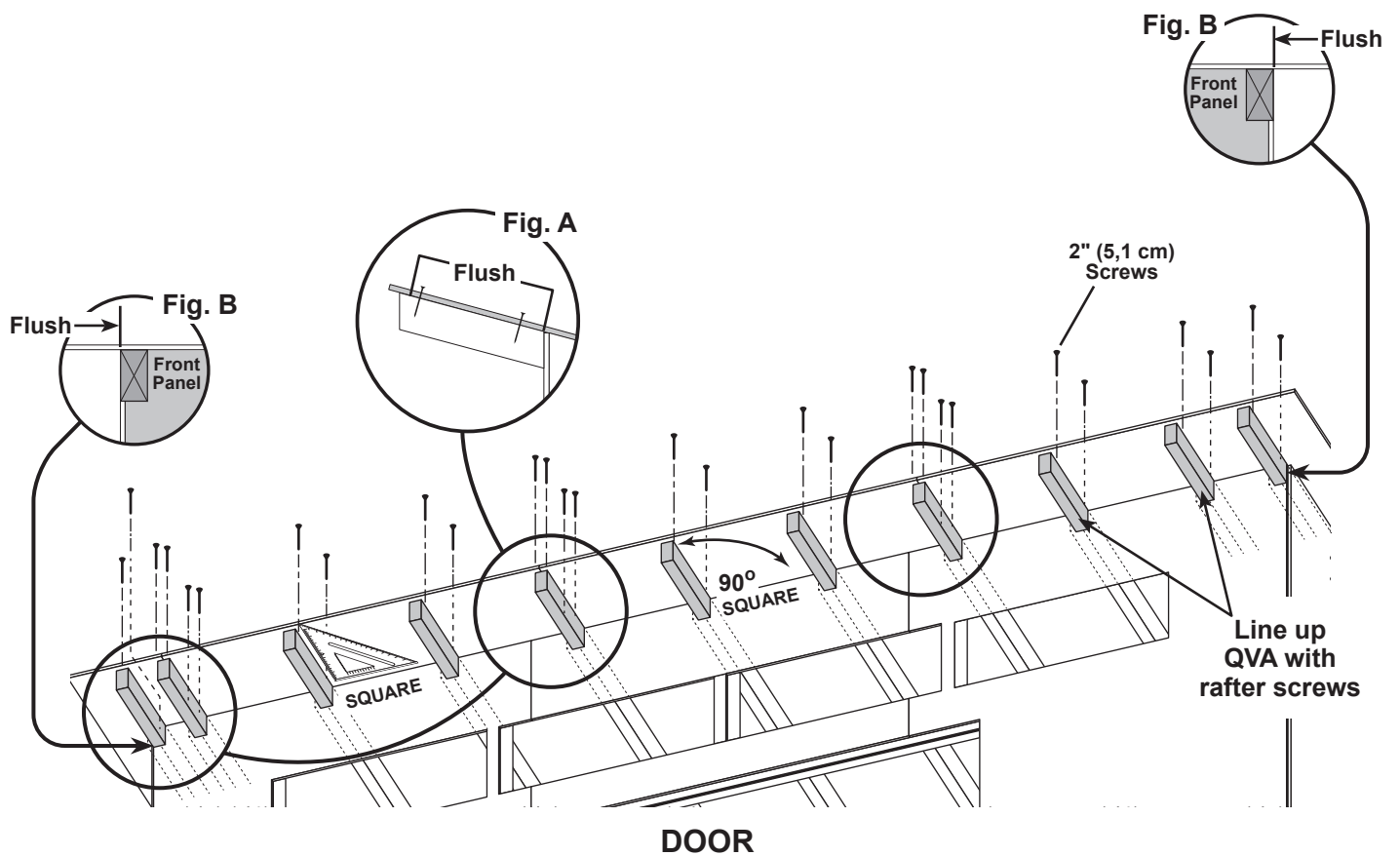

Your rafter extensions are now installed.

SIDE RAKE FRAMING

PARTS REQUIRED:

x2 **THB**
1 x 3 x 31-15/16" (2,5 x 7,6 x 81,1 cm)

x2 **HJ**
1 x 3 x 72" (2,5 x 7,6 x 182,8 cm)

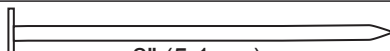
x16  2" (5,1 cm)

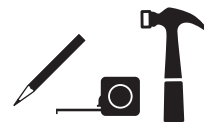

✓ **BEGIN**

1 Align **THB** edge flush with rafter extension (**Fig A**). Secure with (3) 2" nails (**Fig B**).

2 Install **HJ** flush to **THB** and secure with (5) 2" nails. (**Fig A**, **Fig. B**)

Repeat steps on opposite side.

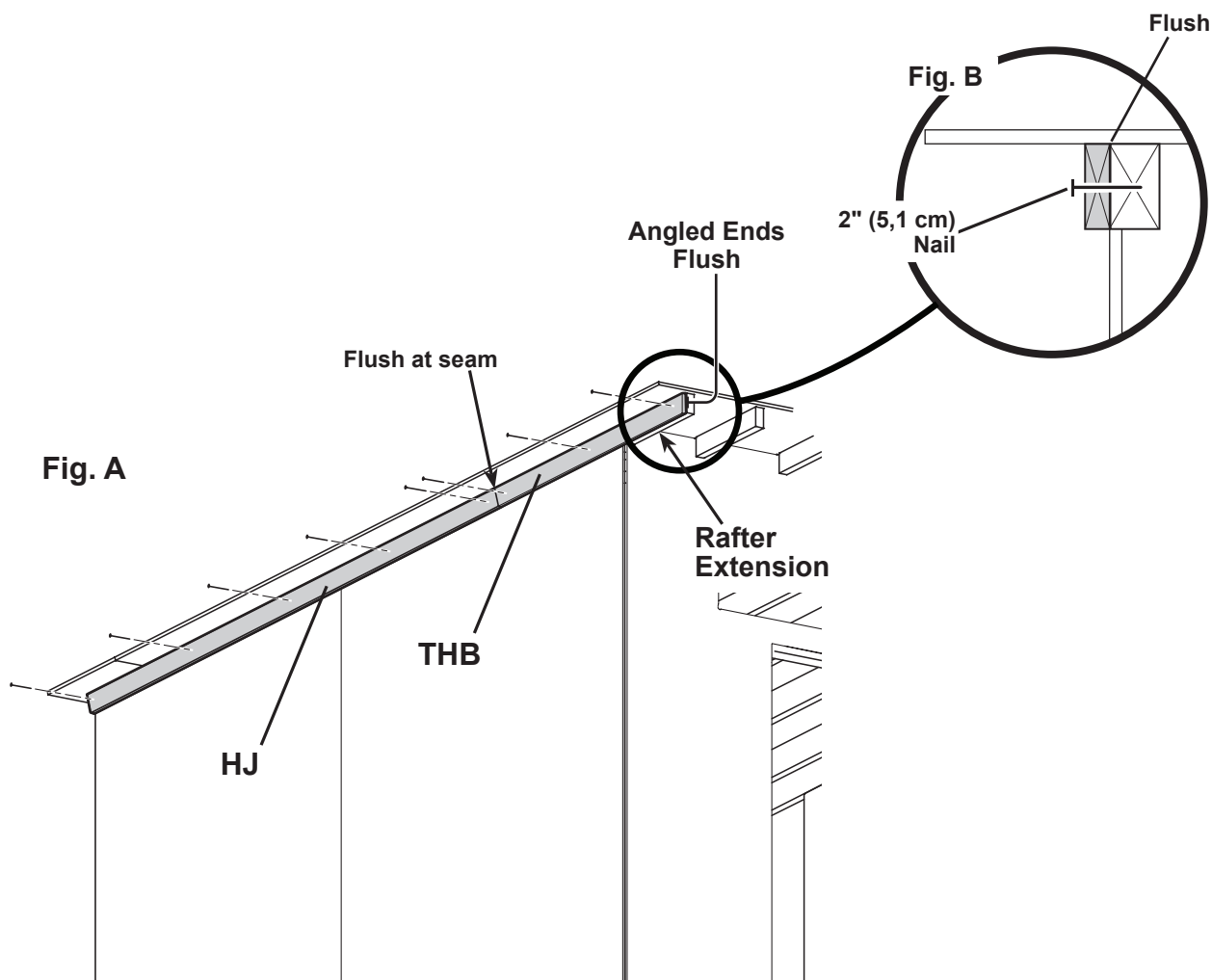

You have finished installing your gable rake framing.

SIDE SOFFIT

PARTS REQUIRED:

x2

3/8" x 5-1/4" x 94-7/16" (1 x 13,3 x 242,5 cm)

x14

2" (5,1 cm)



✓ **BEGIN**

1 Install **94-7/16"** soffit primed side down flush to front wall panel (**Fig. A**).

Secure to side rake frame **THB** with (7) 2" finishing nails (**Fig. A, B**).

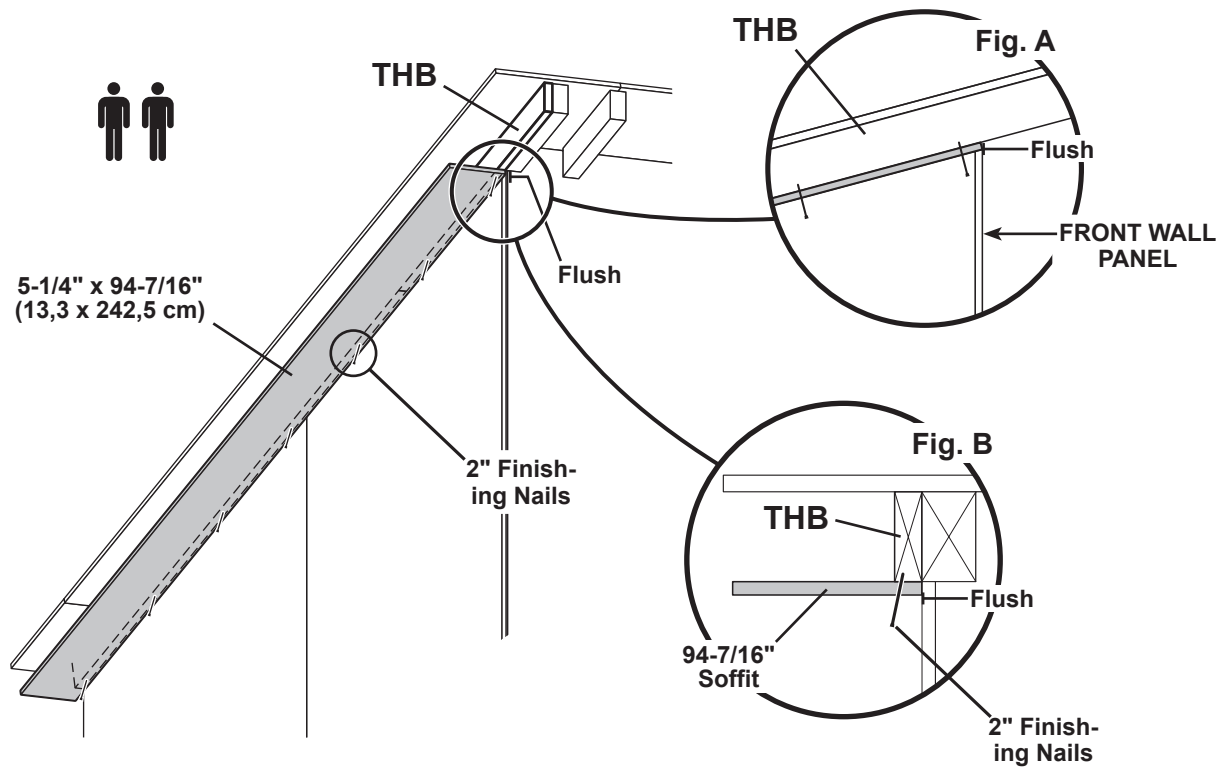

Repeat steps on opposite side.



Your side soffit panels are now installed.

FRONT SOFFIT

PARTS REQUIRED:

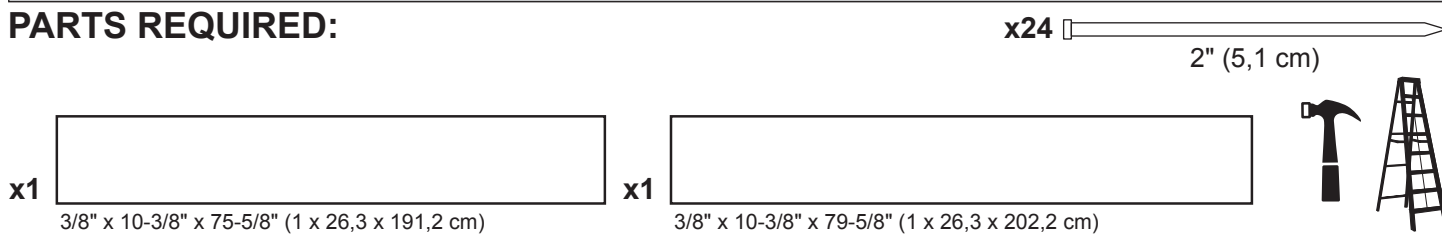

✓ BEGIN

- 1 Install 75-5/8" and 79-5/8" soffit panel primed side out under rafter extensions and flush to side wall soffit (Fig. A). Ensure each soffit is flush to front wall panel. Secure soffit panels with (2) 2" finishing nails into each rafter extension. Use (4) finishing nails at seam (Fig. B).

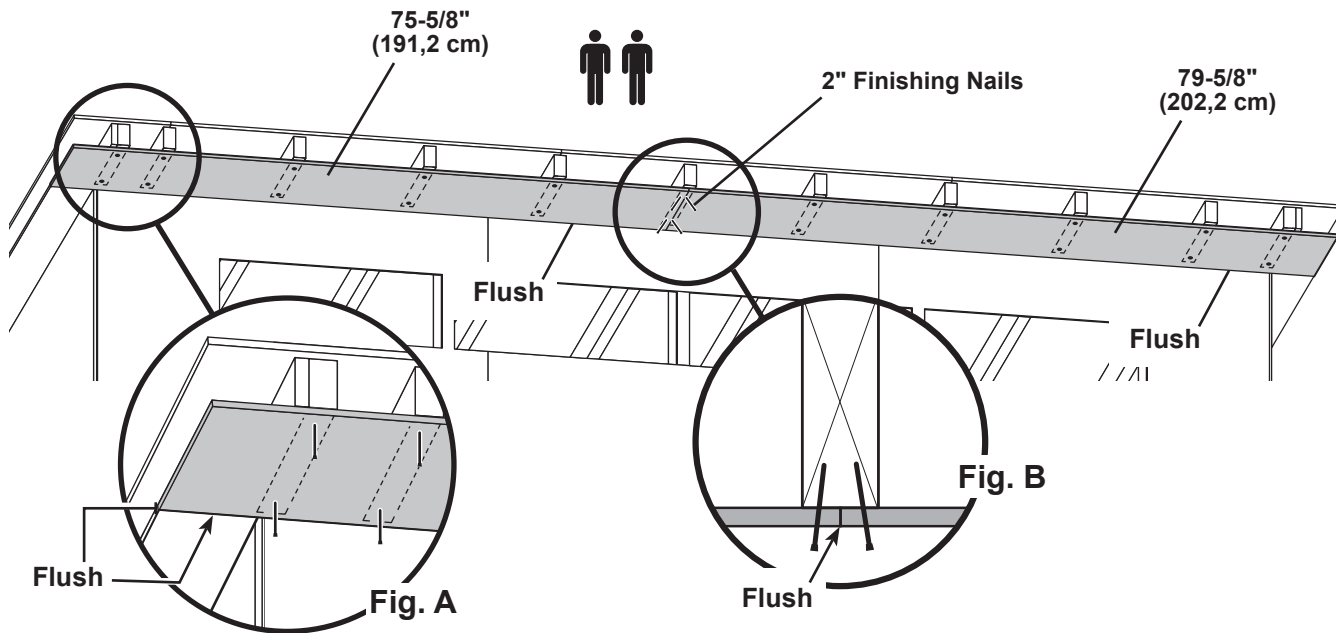

Your front soffit panels are now installed.

FRONT FASCIA TRIM

PARTS REQUIRED:

x1 **WAB**
19/32" x 3-1/2" x 60-1/2" (1,5 x 8,8 x 153,7 cm)

x10  2" (5,1 cm)

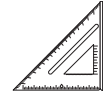

✓ BEGIN

- 1 Measure 1/4" past left roof panel and line up **WAB** primed side out and flush up under roof panels (**Fig. A**). Right side of **WAB** is approximately 3/4" from center of rafter extension (**Fig. B**). Secure **WAB** with 2" finishing nails into rafter extensions (**Fig. B**).

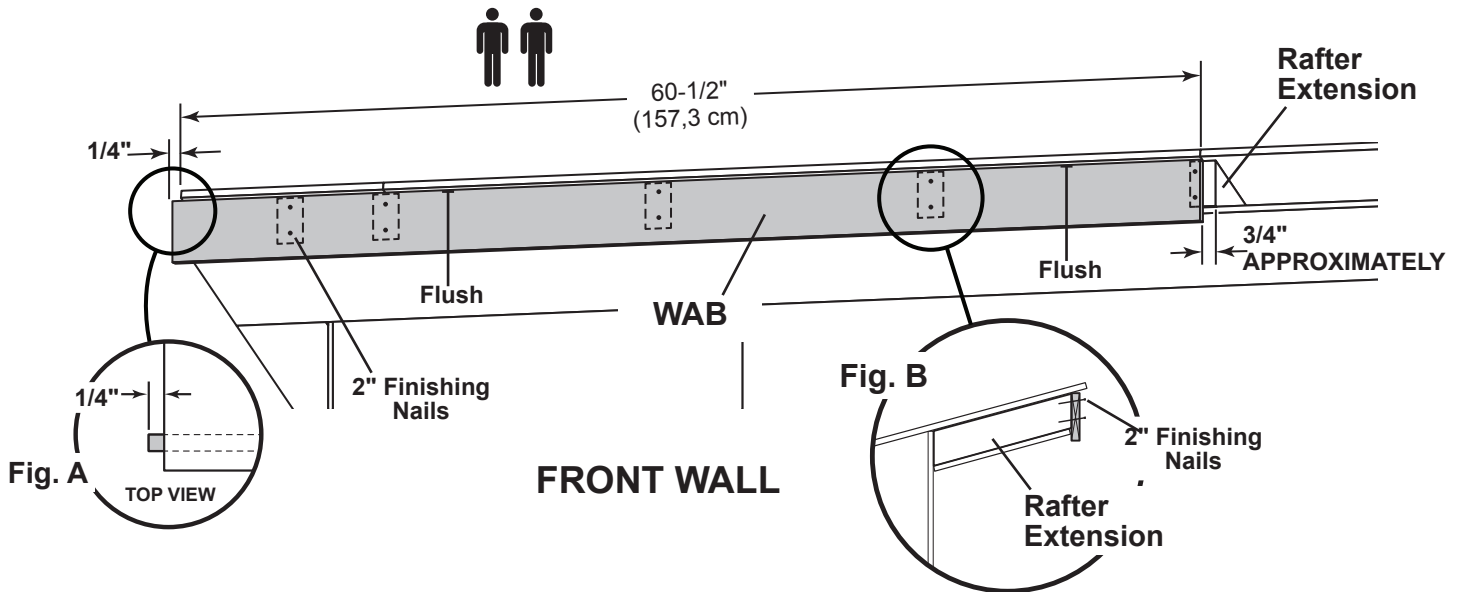

FRONT FASCIA TRIM

PARTS REQUIRED:

x1 **ZX**
19/32" x 3-1/2" x 96" (1,5 x 8,8 x 243,8 cm)

x14 
2" (5,1 cm)

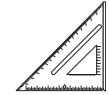

- 2 Position **ZX** primed side out, flush with **WAB** and flush up under roof panels.
Secure **ZX** using 2" finishing nails into rafter extensions (**Fig. B**).

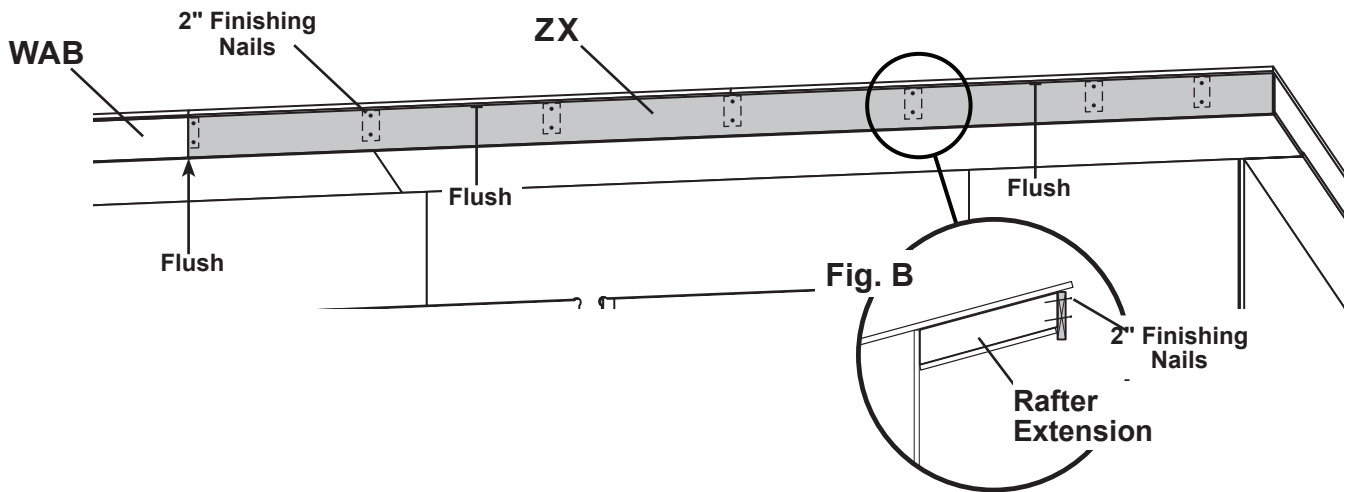

Your front fascia is now installed

SIDE FASCIA TRIM ASSEMBLY

PARTS REQUIRED:

x1 **UDR**
19/32" x 3-1/2" x 61-1/16" (1,5 x 8,9 x 155,1 cm)

x1 **UDL**
19/32" x 3-1/2" x 61-1/16" (1,5 x 8,9 x 155,1 cm)

x2 **OY**
2 x 3 x 72" (5,1 x 7,6 x 182,8 cm)

x2 **RMA**
2 x 3 x 31-15/16" (5,1 x 7,6 x 81,1 cm)

x2 **WQA**
19/32" x 3-1/2" x 45" (1,5 x 8,9 x 114,3 cm)

x28  2" (5,1 cm)

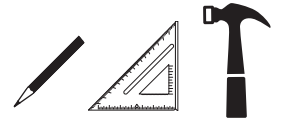

✓ BEGIN

- 1 To build right side fascia assembly, place **RMA** and **OY** end to end on a flat surface (**Fig. A**).

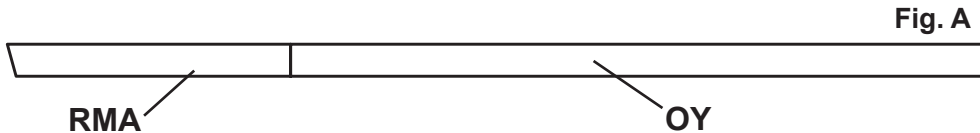

- 2 Place **UDR** and **WQA primed side up** and flush with **RMA** and **OY**. Secure with 2" finishing nails, as shown (**Fig. B, C**).

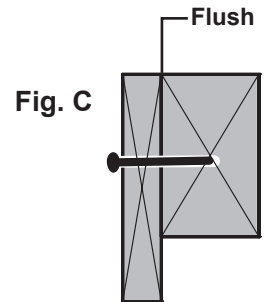
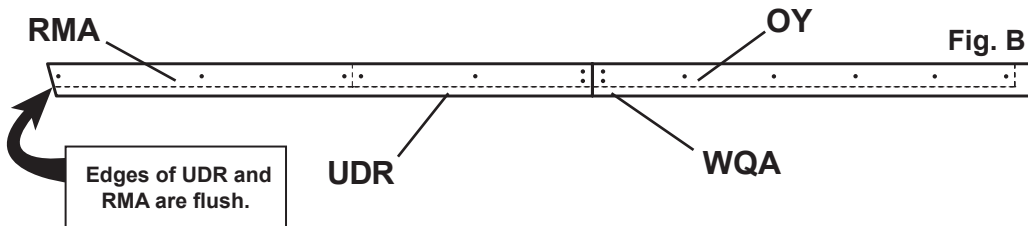

- 3 To build left side fascia assembly, place **RMA** and **OY** end to end on a flat surface (**Fig. C**).

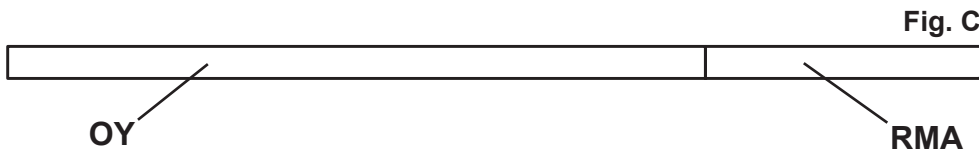

- 4 Place **UDL** and **WQA primed side up** and flush with **RMA** and **OY**. Secure with 2" finishing nails as shown (**Fig. D, E**).

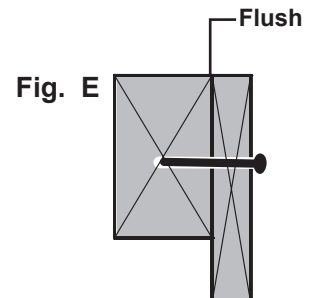
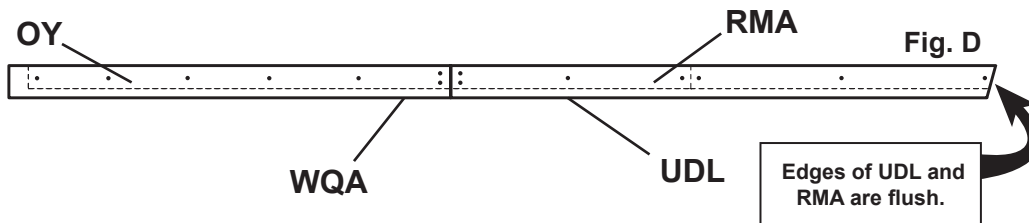

You have finished assembling the side fascia trim.

SIDE FASCIA TRIM

PARTS REQUIRED:

x1 **LEFT FASCIA ASSEMBLY**

x12 **2" (5,1 cm)**

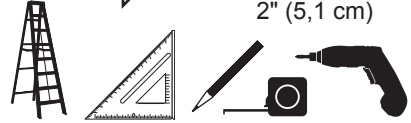

✓ **BEGIN**

- 1 Place left side fascia assembly between roof sheathing and side soffit (**Fig. A, Fig. B**).
- 2 Install fascia assembly under roof panels flush with front fascia board. Secure with (6) 2" screws through roof sheathing (**Fig. A**).

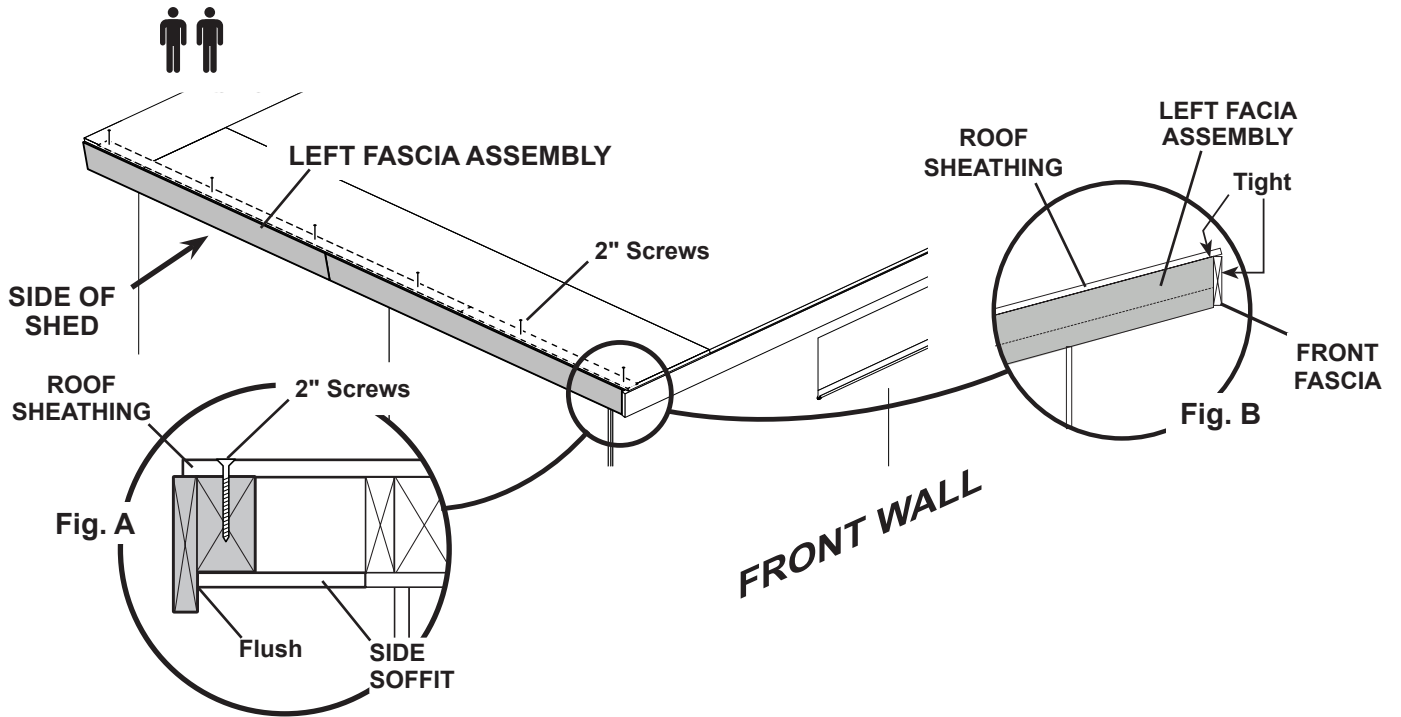

SIDE FASCIA TRIM

PARTS REQUIRED:

x1 **RIGHT FASCIA ASSEMBLY**



x18  2" (5,1 cm)

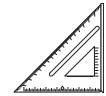

3 Nail up through side soffit into fascia assembly. Secure with (7) 2" finishing nails (**Fig. C**).

4 Secure front fascia to side fascia with (2) 2" finishing nails (**Fig. D**).

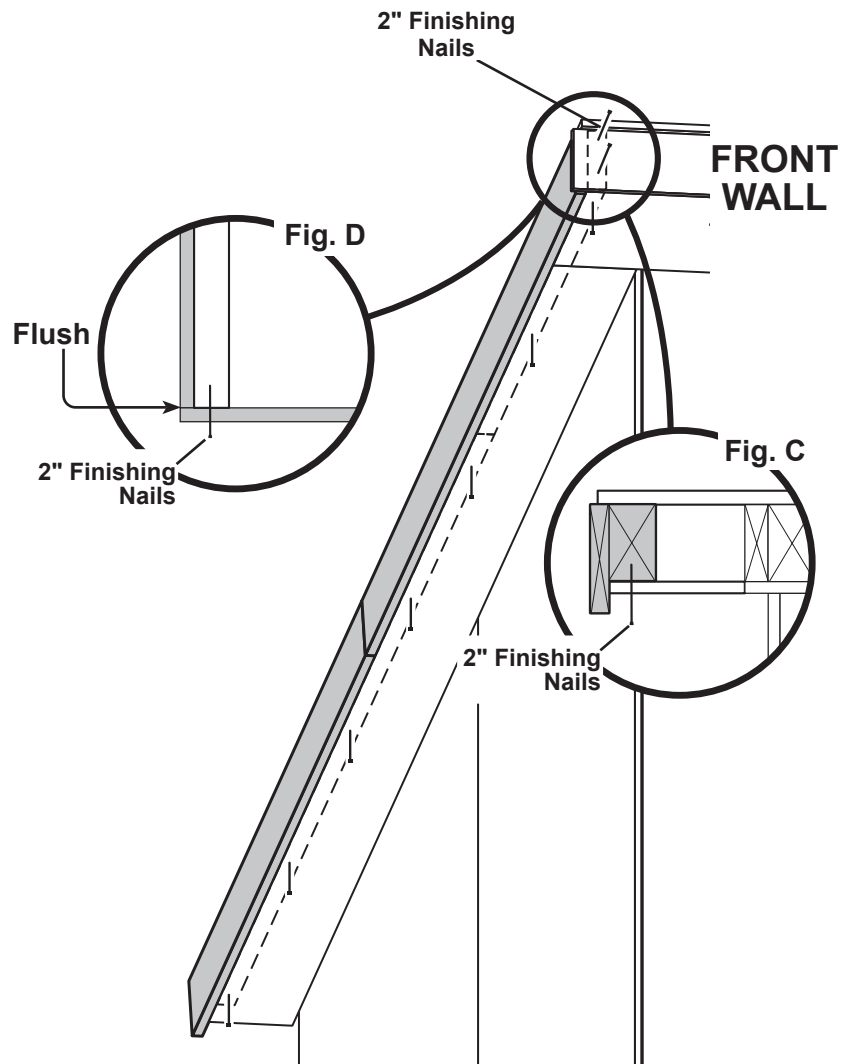

Repeat steps to install right side fascia.



Your side fascia trim is now installed.

REAR FASCIA TRIM

PARTS REQUIRED:

x1 **GKA**
2 x 3 x 59-1/4" (5,1 x 7,6 x 150,5 cm)

x1 **PT**
2 x 3 x 96" (5,1 x 7,6 x 243,8 cm)

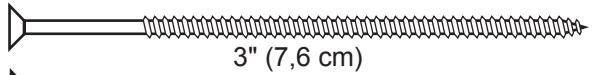
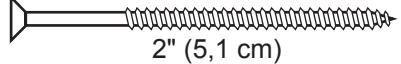
x2  3" (7,6 cm)
x10  2" (5,1 cm)



BEGIN

1 Install **PT** and **GKA** using 2" wood screws through roof sheathing (**Fig. A**).

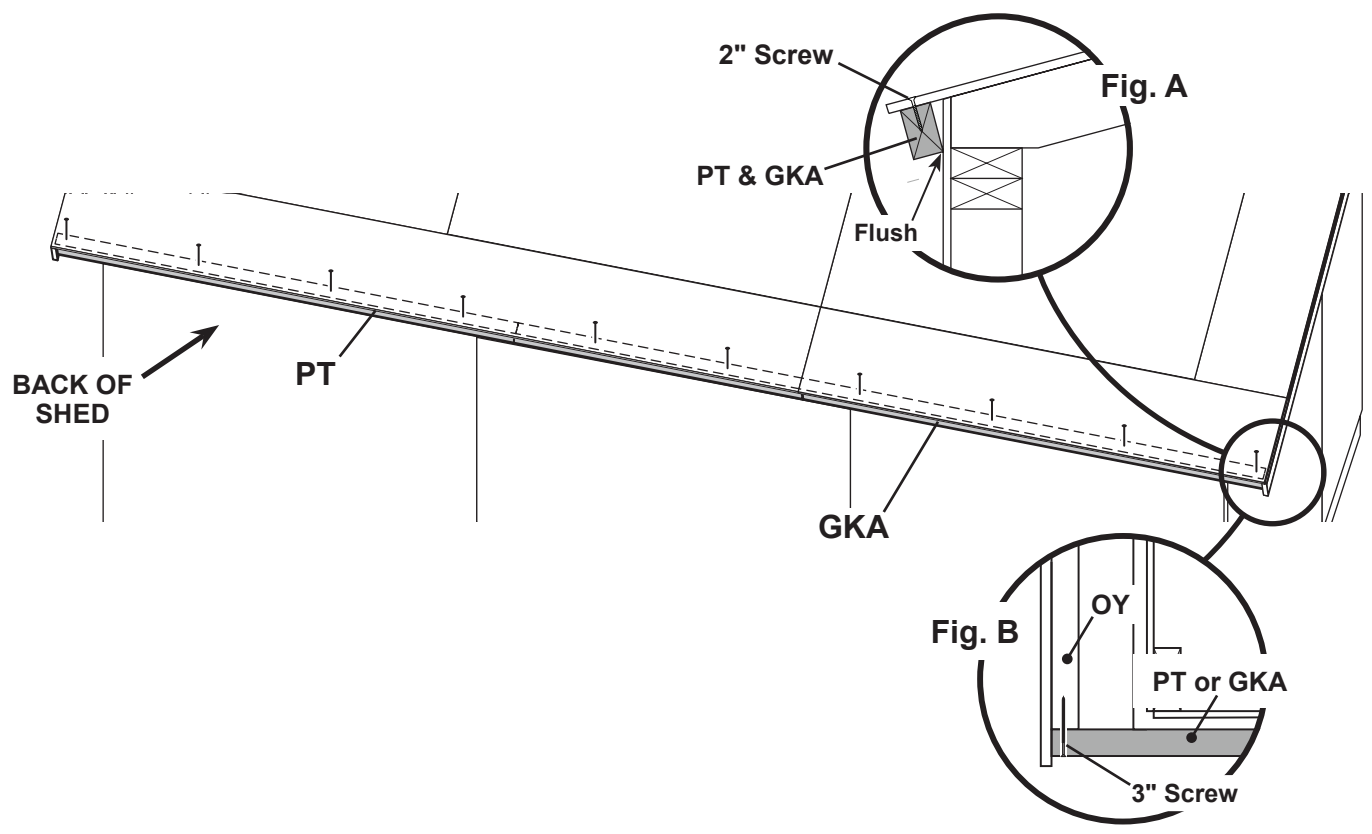

2 Secure **PT** and **GKA** with (1) 3" screw through side fascia trim nailer **OY** (**Fig. B**).

REAR FASCIA TRIM

PARTS REQUIRED:

x1 **HBA**
19/32" x 3-1/2" x 59-1/4" (1,5 x 8,8 x 150,5 cm)

x1 **ZX**
19/32" x 3-1/2" x 96" (1,5 x 8,8 x 243,8 cm)

x12  2" (5,1 cm)



- 3 Install **HBA** and **ZX** to **PT** and **GKA**. Secure with 2" finishing nails (**Fig. C**). Ensure trim is *primed side out*.

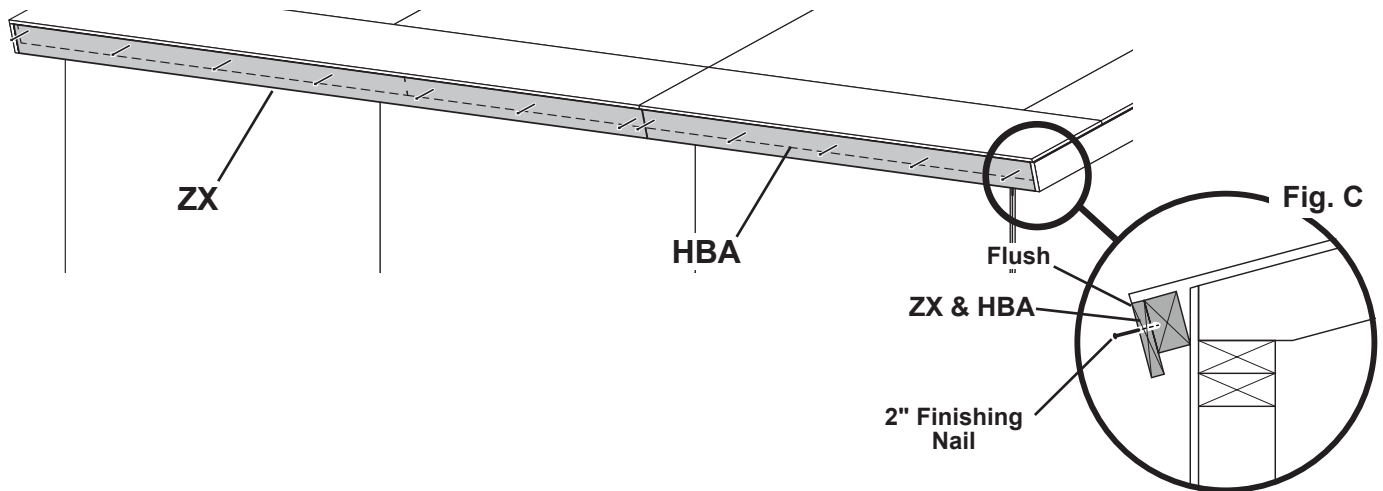

Your rear fascia trim is now installed.

BACK CORNER TRIM

PARTS REQUIRED:

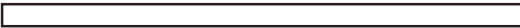
x2 
3/8" x 2" x 73-5/16" (0,9 x 5,1 x 186,2 cm)

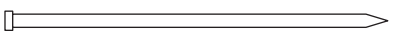
x14 
2" (5,1 cm)



✓ **BEGIN**

1 Place **73-5/16"** back corner trim flush to bottom of back soffit board (**Fig. A**) and flush with side panel (**Fig. B**).

Secure trim with (14) 2" finishing nails into corner wall framing. Space nails equally.

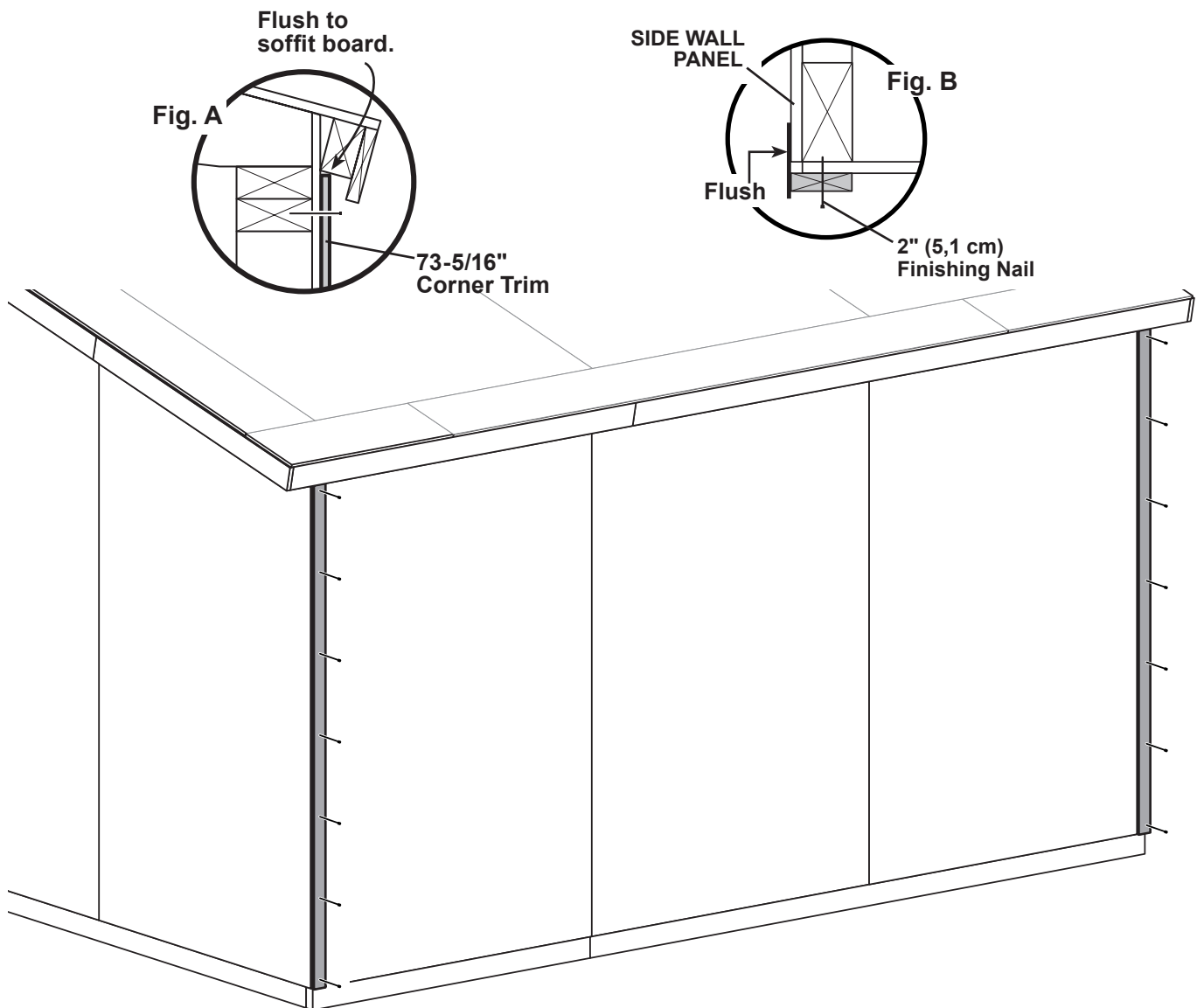





FINISH

Your back corner trim is now installed.

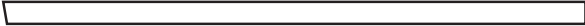
SIDE CORNER TRIM

PARTS REQUIRED:

- x1  3/8" x 2" x 73-7/16" (0,9 x 5,1 x 186,5 cm)
- x1  3/8" x 2" x 73-7/16" (0,9 x 5,1 x 186,5 cm)
- x1  3/8" x 2" x 93-1/8" (0,9 x 5,1 x 236,5 cm)
- x1  3/8" x 2" x 93-1/8" (0,9 x 5,1 x 236,5 cm)

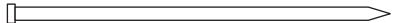
x32  2" (5,1 cm)

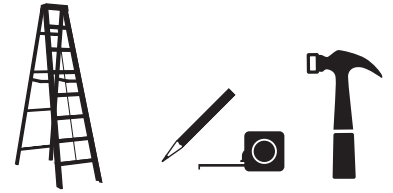

✓ BEGIN

- 1 Install 93-1/8" side front-corner trim flush to front wall panel (Fig. A).
Secure trim with (9) 2" finishing nails spaced evenly.
- 2 Install 73-7/16" side back-corner trim flush to back wall trim (Fig. B).
Secure trim with (7) 2" finishing nails spaced evenly.

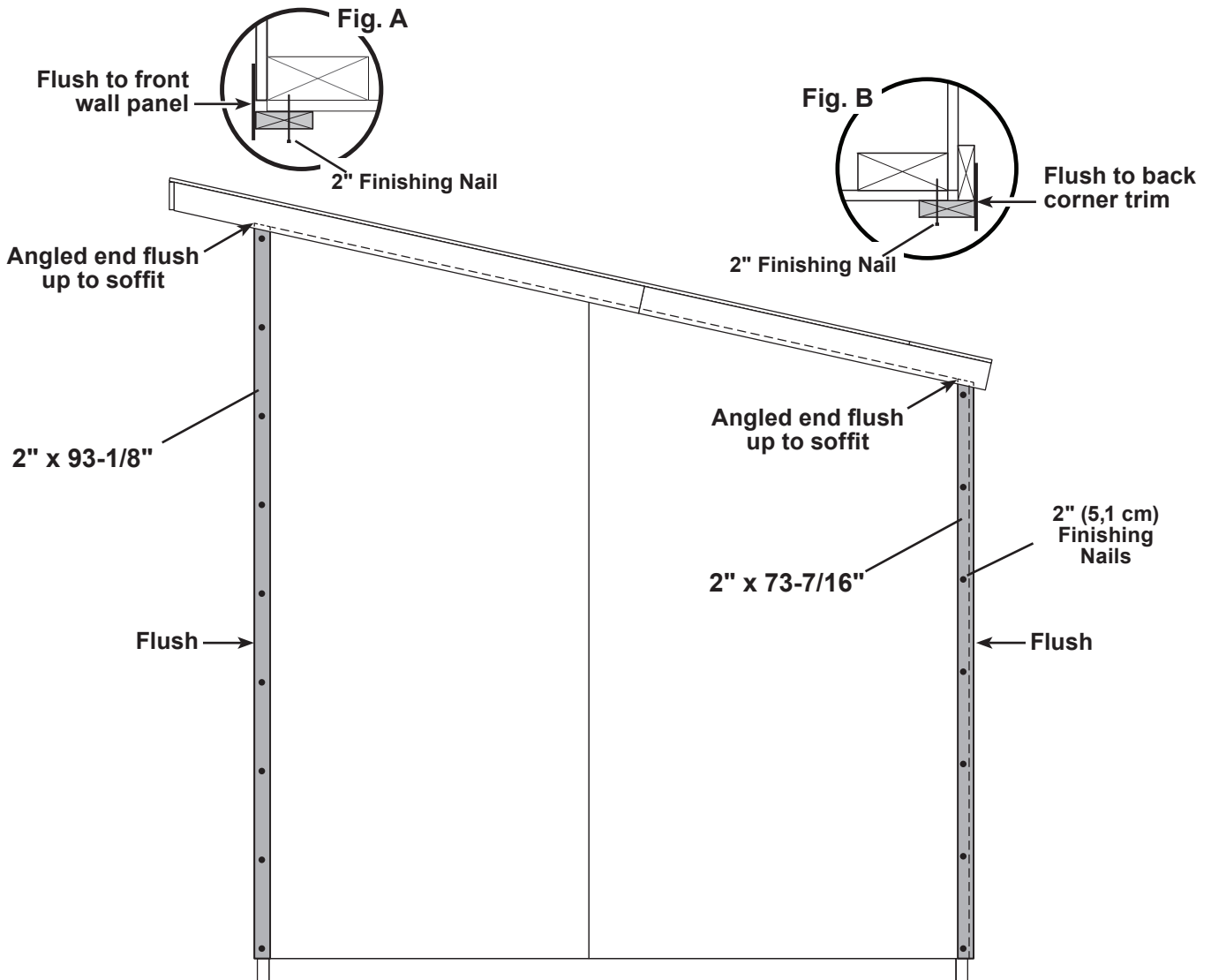

Repeat steps for opposite side trim installation.



FINISH

Your side corner trim boards are now installed.

FRONT TRIM

PARTS REQUIRED:

x2 **ZD**
19/32" x 2-1/2" x 72-3/4" (1,5 x 6,3 x 184,8 cm)

x2 **VAA**
19/32" x 2-1/2" x 90-5/8" (1,5 x 6,3 x 230,2 cm)

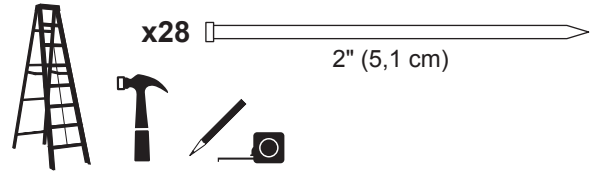

✓ BEGIN

- 1** Install (2) **ZD** trim pieces centered and flush up to soffit.
Secure trim with (14) 2" finishing nails into top plate. Space nails evenly.
- 2** Install **VAA** corner trim flush to side corner trim (**Fig. A**).
Secure trim with (14) 2" finishing nails into wall framing. Space nails evenly.

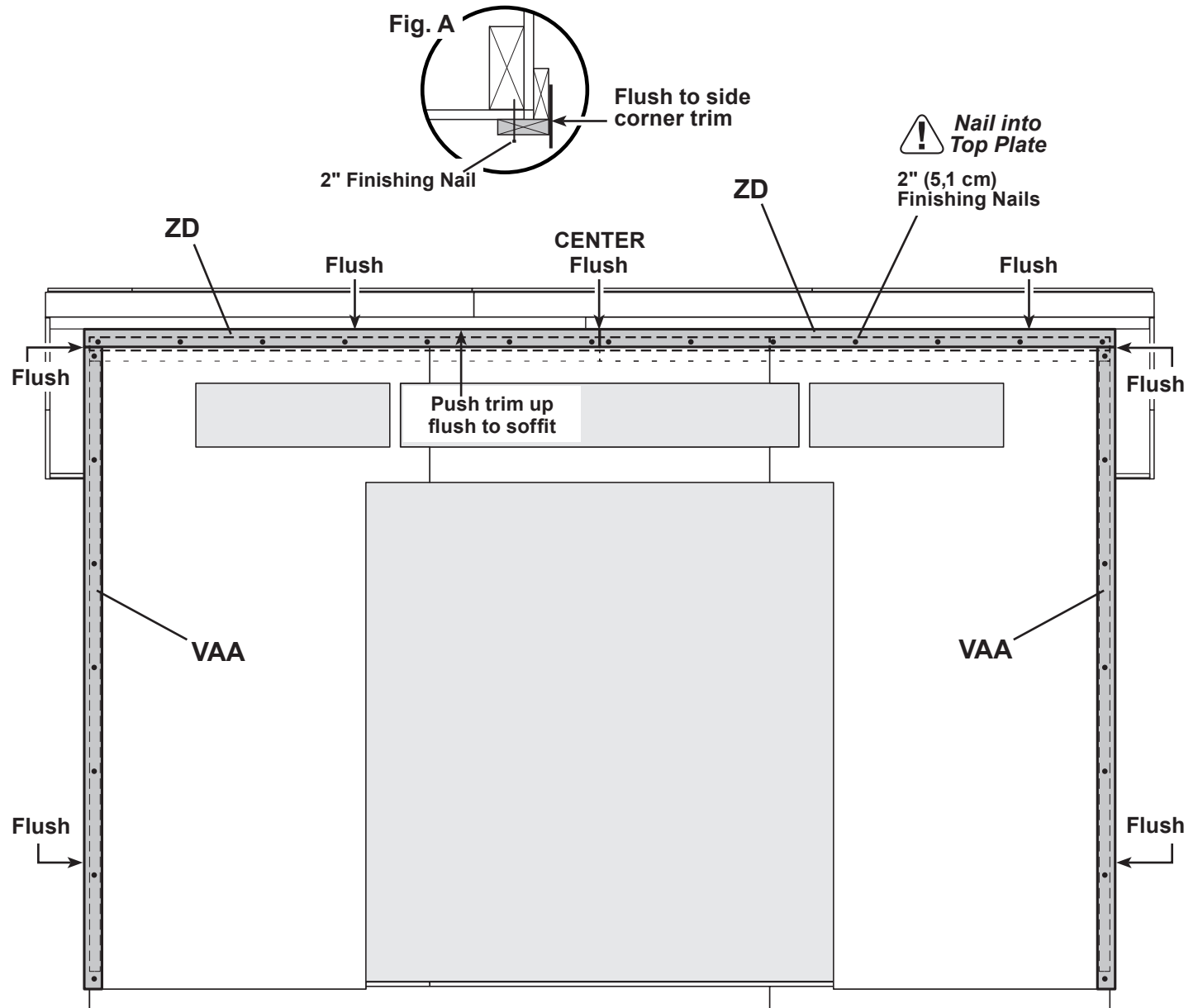

FINISH

Your corner trim and upper gable trim boards are now installed.

FRONT WINDOWS

PARTS REQUIRED:

x4

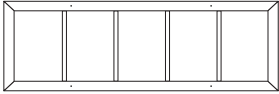

x16

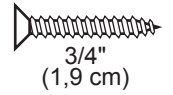

✓ **BEGIN**

1 Apply high quality exterior-grade caulk behind frame near edge before installing to seal window.



You must caulk around windows to validate warranty.

2 Position window in center of opening and level.
Secure with (4) screws on sides of each window.

(4) 3/4" (1,9 cm)
Screws per window

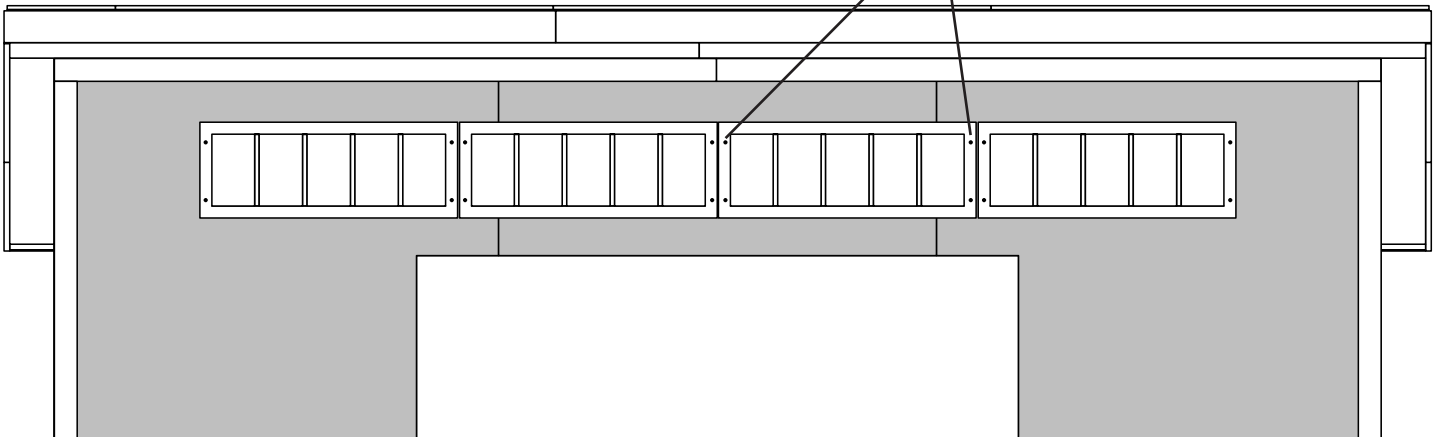



DOORS

PARTS REQUIRED:

x1 **OO**
69" (175,3 cm) Door Stiffener

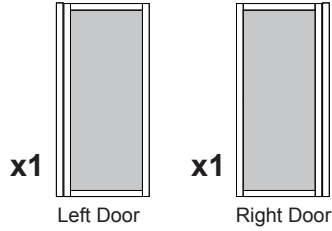
x1 **GAA**
1 x 3 x 5" (2,5 x 7,6 x 12,7 cm)

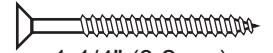

x4  3" (7,6 cm)

x2  1-1/4" (3,2 cm)

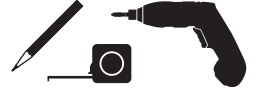

✓ BEGIN

- 1 Arrange parts as shown, on flat surface. **Ensure that the 3/8" offset is to top.**
Look for red (right) and green (left) on hinge board.

Attach temporary supports **OO** and **GAA** as shown.

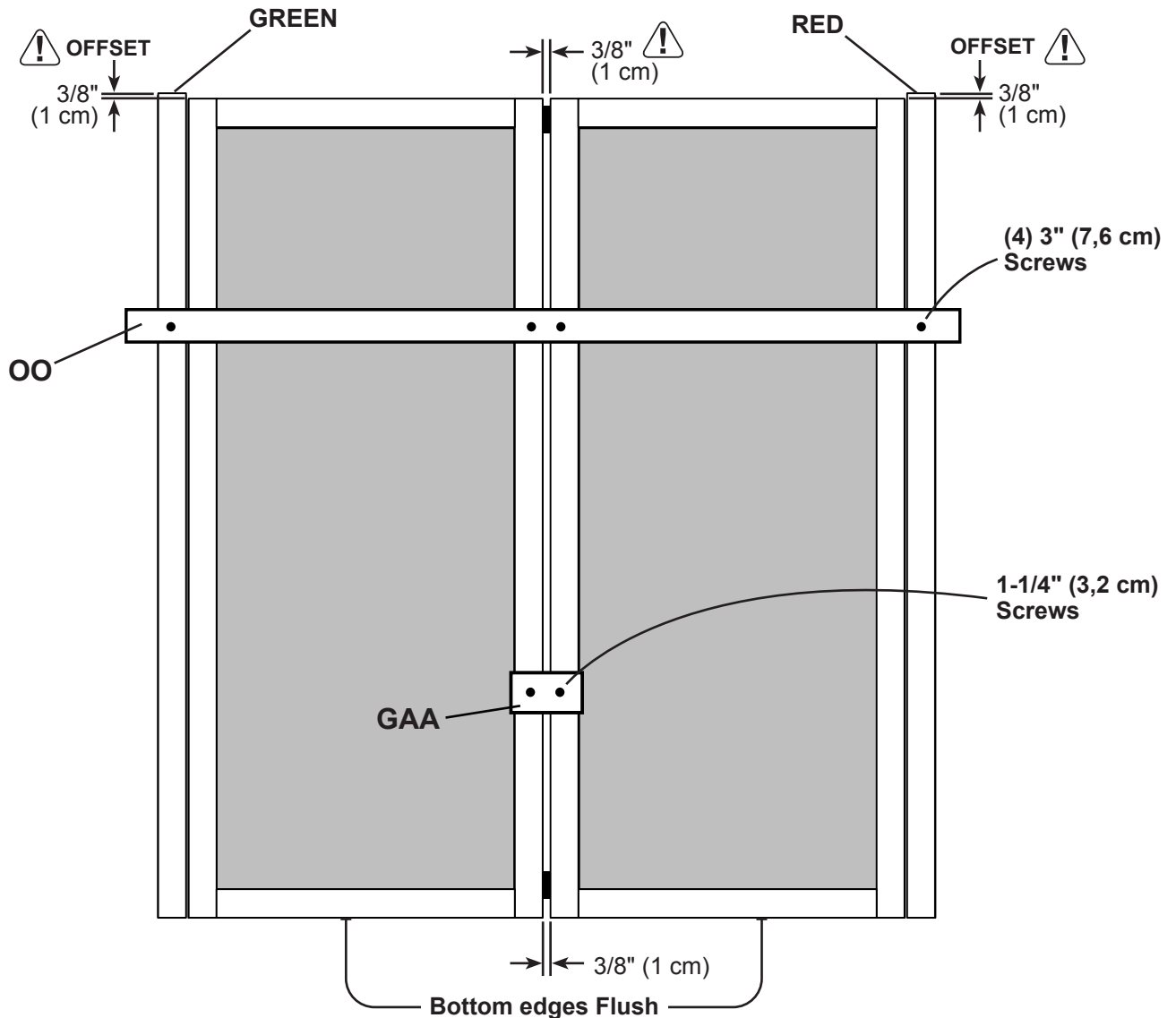

DOORS

PARTS REQUIRED:

x1 **OO**
69" Door Stiffener (175,3 cm)

x12 
3" (7,6 cm)



2 Install **OO** flush under panels.

Secure to floor frame with (2)
3" screws (**Fig. A**).

Mark center of door opening.

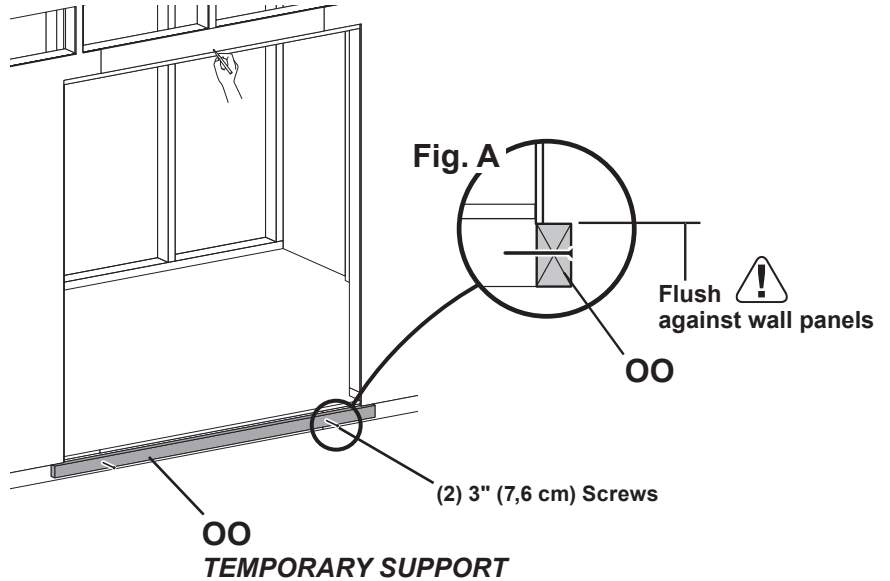

3 Center doors on mark (**Fig. B**).

4 Screw hinge boards into wall supports with (10) 3" screws, as shown.

 **Make sure screws go into framing.**

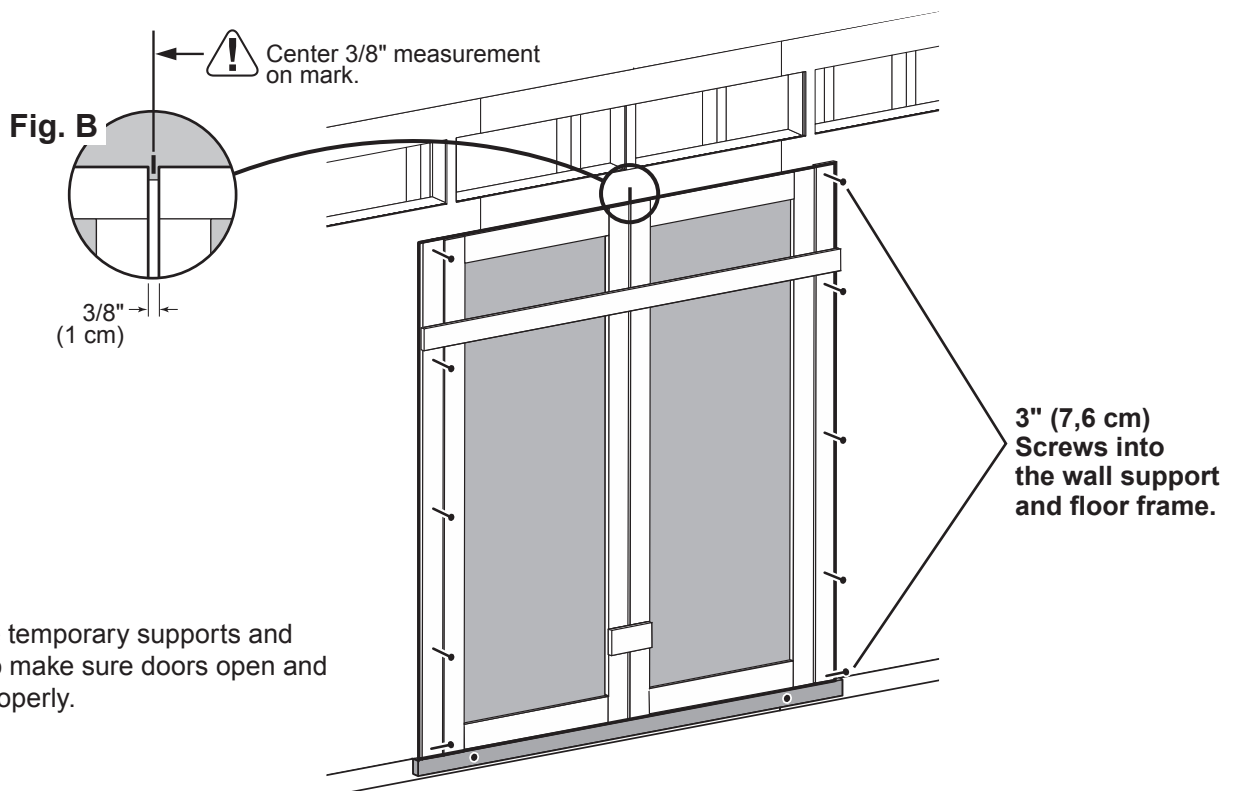

Remove temporary supports and
check to make sure doors open and
close properly.



Your doors are now installed.

DOOR TRIM

PARTS REQUIRED:

x1	WDA Spacer 19/32" x 5-1/2" x 11-5/16" (1,5 x 14 x 28,7 cm)	x1	64" Metal Threshold	x5	2" (5,1 cm)
x8	AH 19/32" x 2-1/2" x 26-5/8" (1,5 x 6,3 x 67,6 cm)		3/4" (1,9 cm) x11 Bagged separately / special coating	x54	3/4" (1,9 cm)
x1	OWB 19/32" x 2" x 72" (1,5 x 5,1 x 182,9 cm)				



✓ BEGIN

- 1 Secure vertical door trim from inside using 3/4" screws (Fig. A).
- 2 Install (4) door rails AH on each door. Use part WDA as a spacing guide (Fig. B). Secure AH with 3/4" screws from inside of doors.
- 3 Reinforce the door trim with 3/4" screws through door panel into trim (Fig. A). Locate screws as shown (Fig. B).
- 4 Center trim OWB over doors and secure using (5) 2" nails into framing.

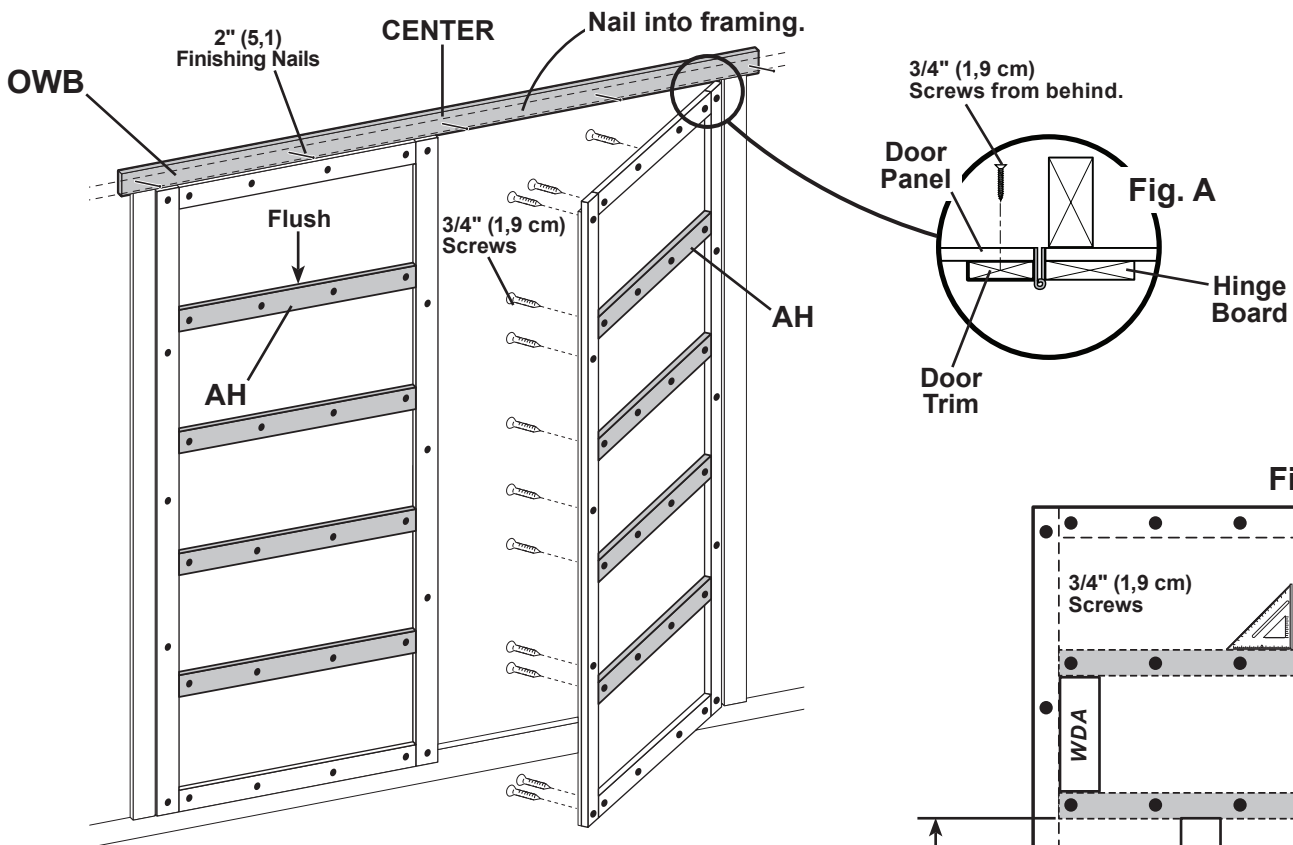

- 5 Center metal threshold between doors and secure with (11) 3/4" special coating screws into floor (Fig. D).

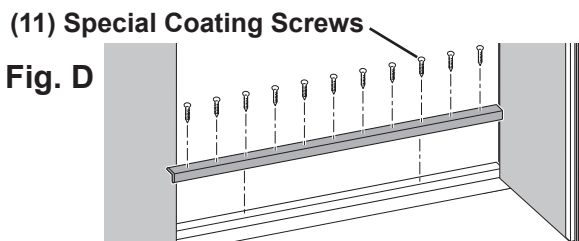

Your door trim and threshold are now installed.

DOOR STIFFENERS

PARTS REQUIRED:

x2 **OO**
69" Door Stiffener (175,3 cm)

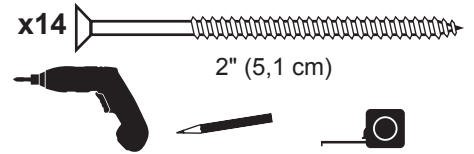

✓ BEGIN

- 1 Center **OO** vertically on the left door in the door opening flush with the edge of door (Fig. A).
- 2 Secure using (5) 2" screws through outside trim into **OO** (Fig. B)

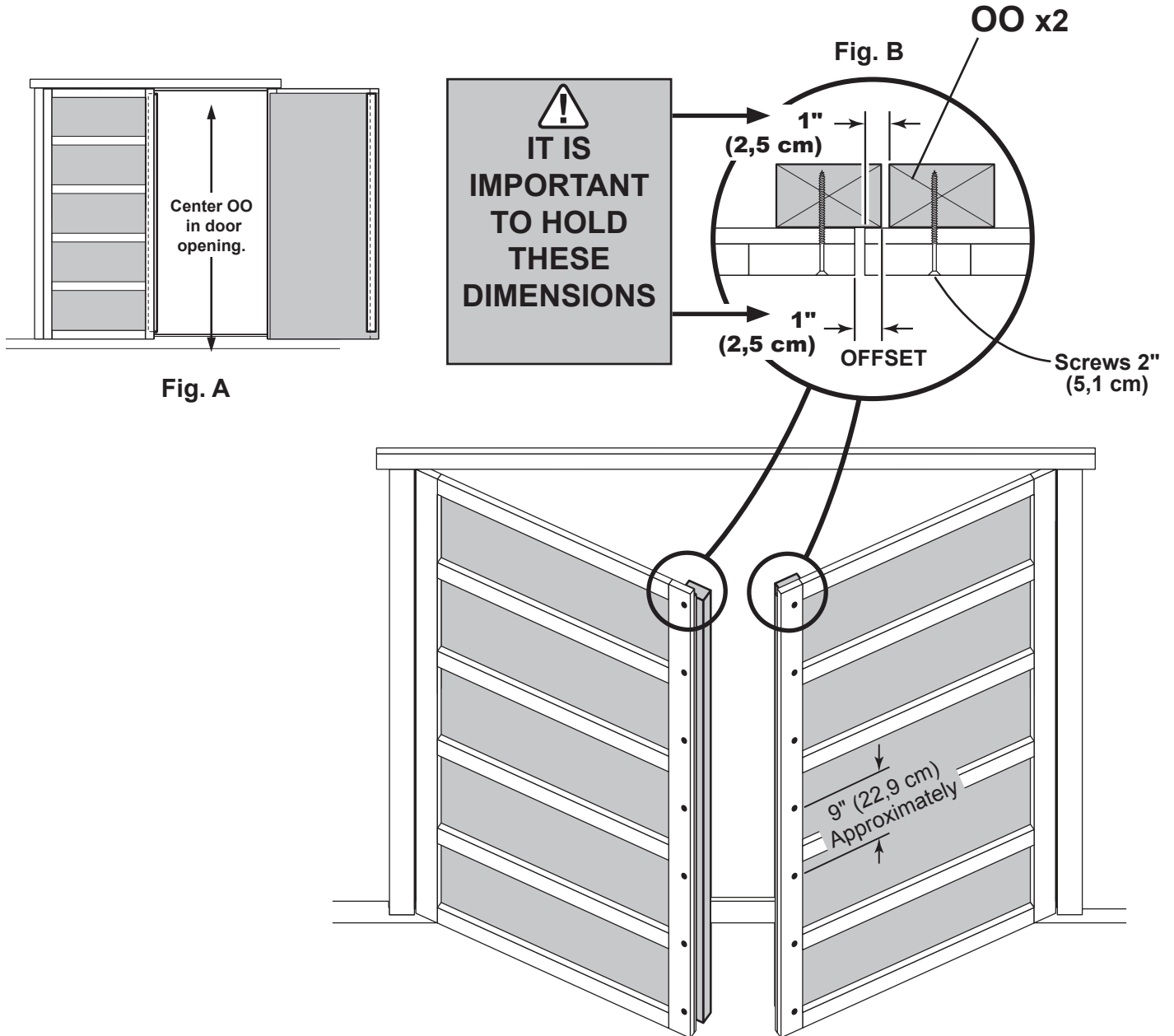

Repeat steps to install **OO** on right door (Fig B).



Your door stiffeners are now installed.

DOOR HARDWARE

PARTS REQUIRED:

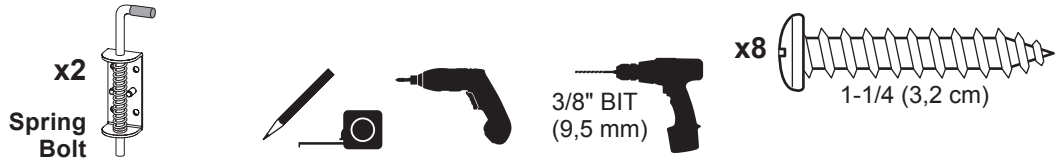

✓ BEGIN

- 1 Flush and center top spring bolt at the top of **OO** (Fig. A). Secure with (4) 1-1/4" screws. Mark spring bolt pin location on over door frame. Drill a 1-1/2" deep hole using a 3/8" drill bit.
- 2 Flush and center bottom spring bolt to bottom of **OO** (Fig. B). Secure with (4) 1-1/4" screws.

Fig. A

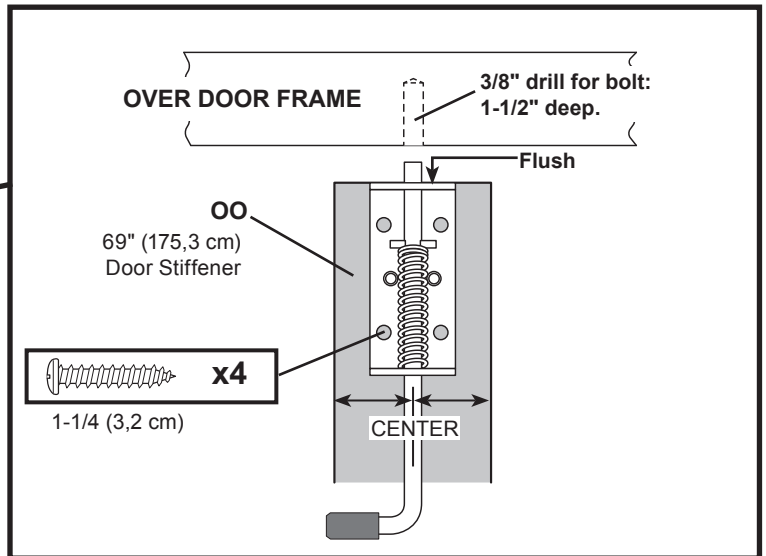
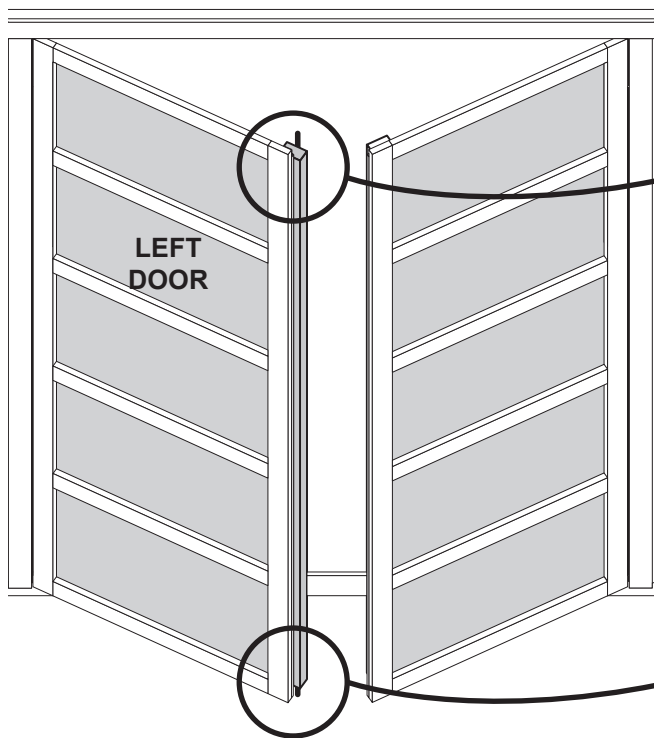
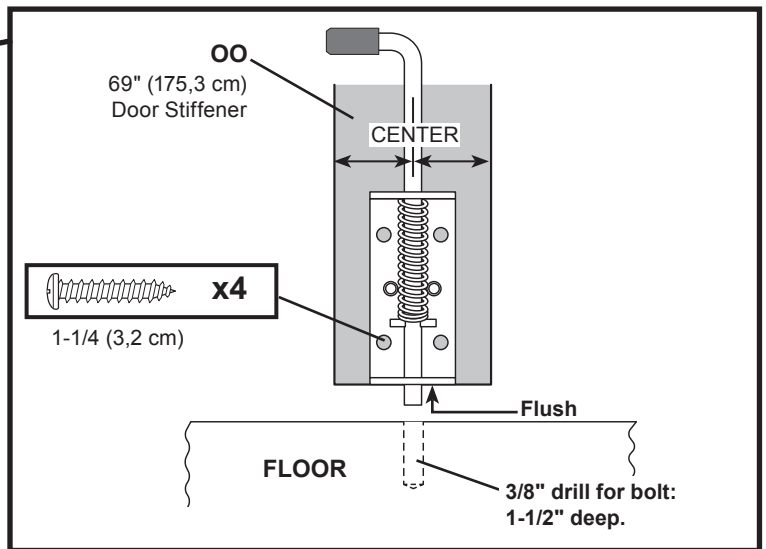
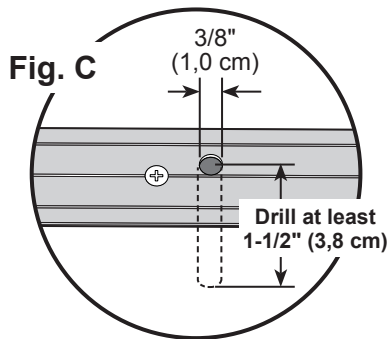

Fig. B

- 3 With door closed, mark center location of spring bolt pin on metal threshold (Fig. C).



- 4 Raise spring bolt pin and open door. Pre drill metal threshold at mark using a 3/16" bit. Re-drill hole using a 3/8" bit. Drill at least 1-1/2" deep into floor (Fig. C).



Your spring bolts are now installed.

DOOR HARDWARE

PARTS REQUIRED:

x1

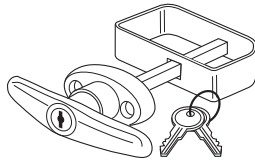

x2

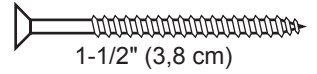

✓ BEGIN

- 1 Measure and mark position on right door as shown.
Pre-drill 1/4" hole at mark. Finishing hole using 1/2" drill bit.

- 2 Position hardware in hole and secure with screws as shown.

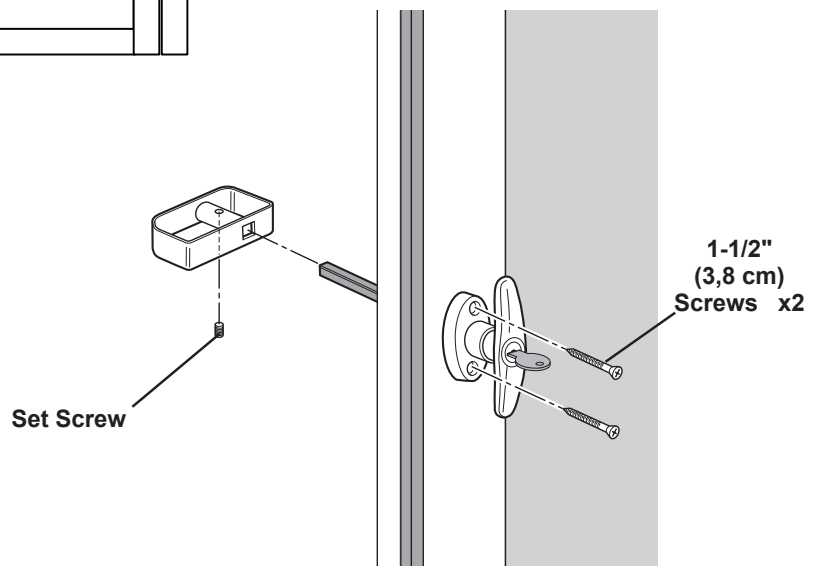
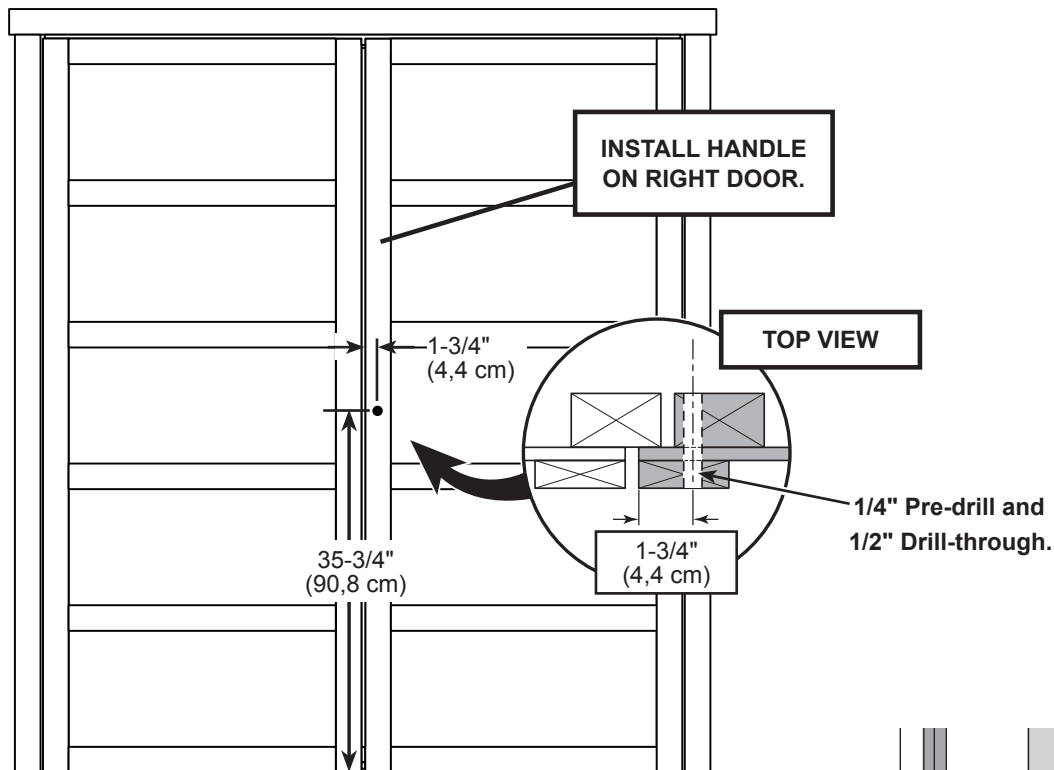

FINISH

Your door handle is now installed.

FRONT WINDOW TRIM

PARTS REQUIRED:

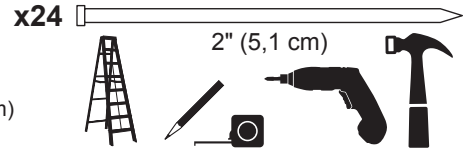

x4 **TTB**
19/32" x 2-1/2" x 58-3/4" (1,5 x 6,3 x 149,2 cm)

x5 **EY**
19/32" x 2-1/2" x 9" (1,5 x 6,4 x 22,9 cm)

✓BEGIN

- 1 Install (2) **TTB** centered on over door trim.
Flush bottom of **TTB** to top of over door trim.
Secure with (8) 2" finishing nails, as shown. Space nails evenly.

 **Do not nail into window flange.**

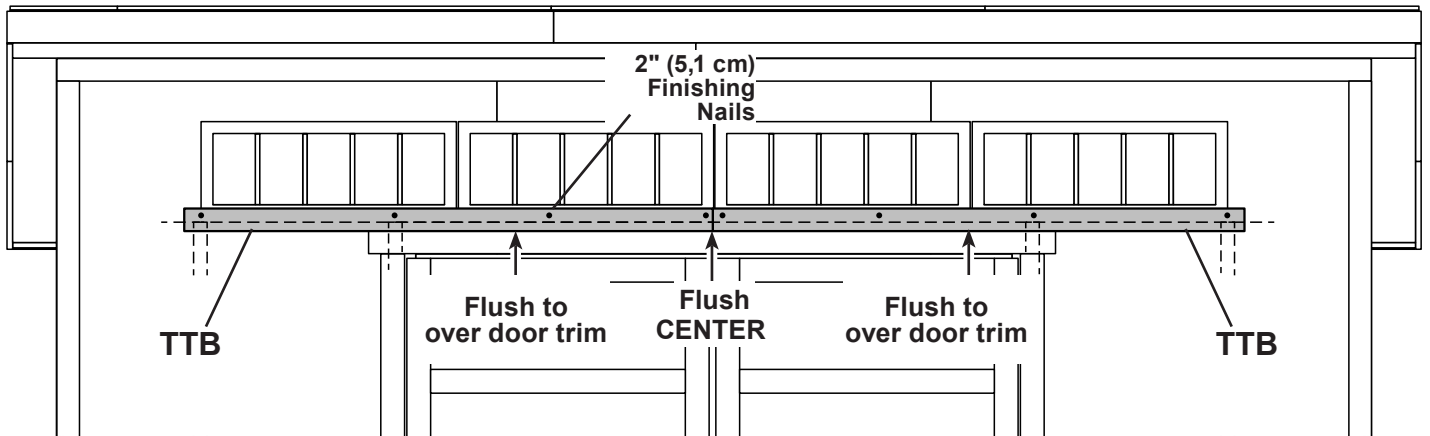

- 2 Center (5) **EY** on gap between window frames, as shown.
Secure with (10) 2" finishing nails.

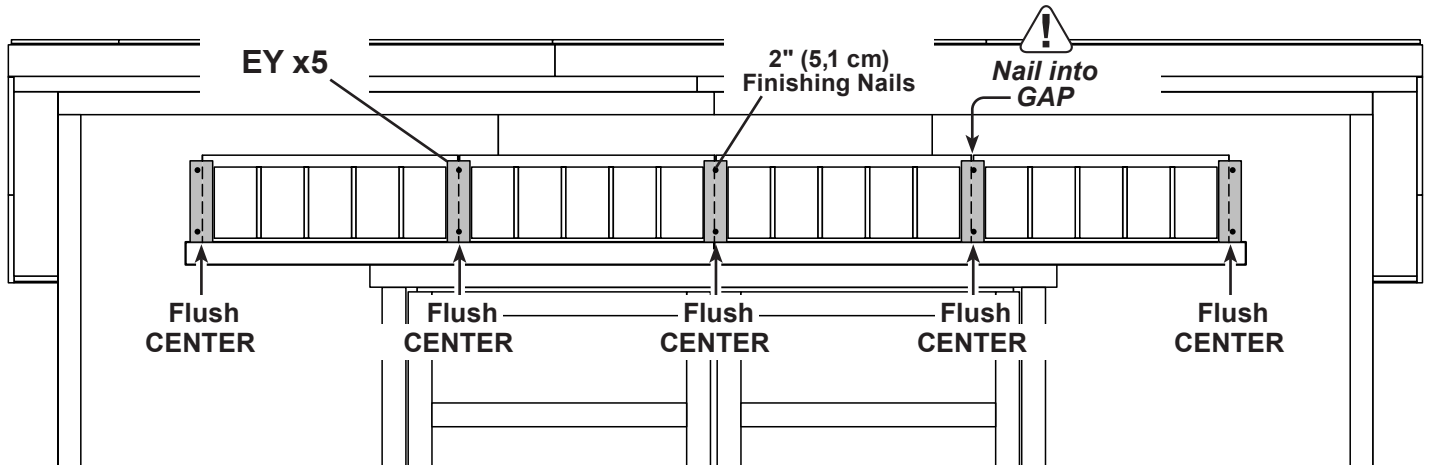

FRONT WINDOW TRIM

PARTS REQUIRED:



- 3** Install (2) TTB on window trim, centered as shown. Secure with (6) 2" finishing nails.

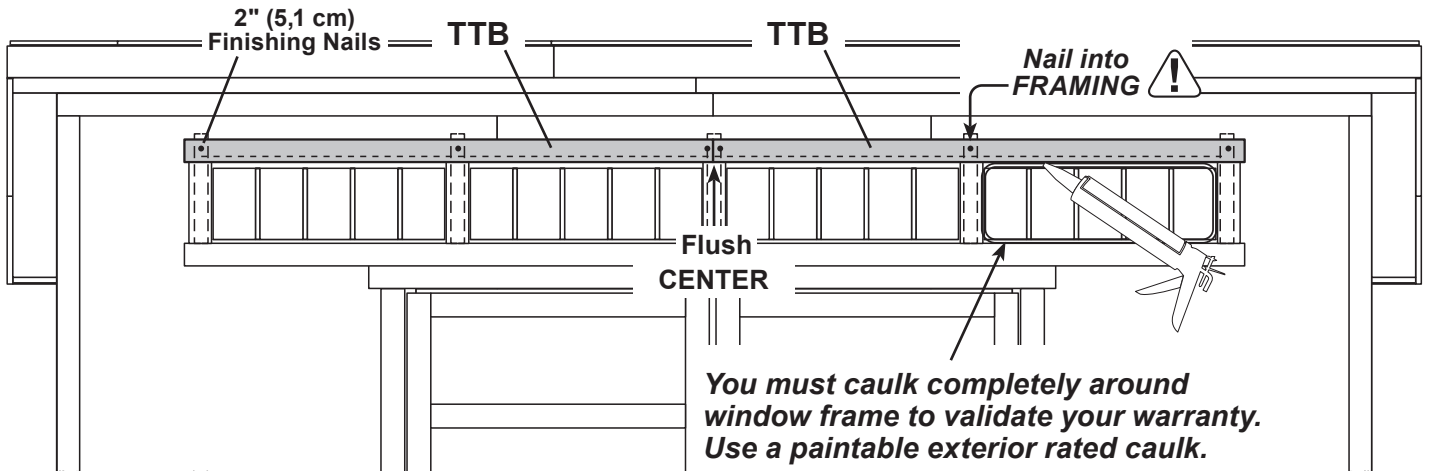

- 4** Install (4) 3/4" screws from inside into window trim, as shown.

 **Do not screw into window flange.**

NOTE: Snip off protruding finishing nails from inside of front wall.

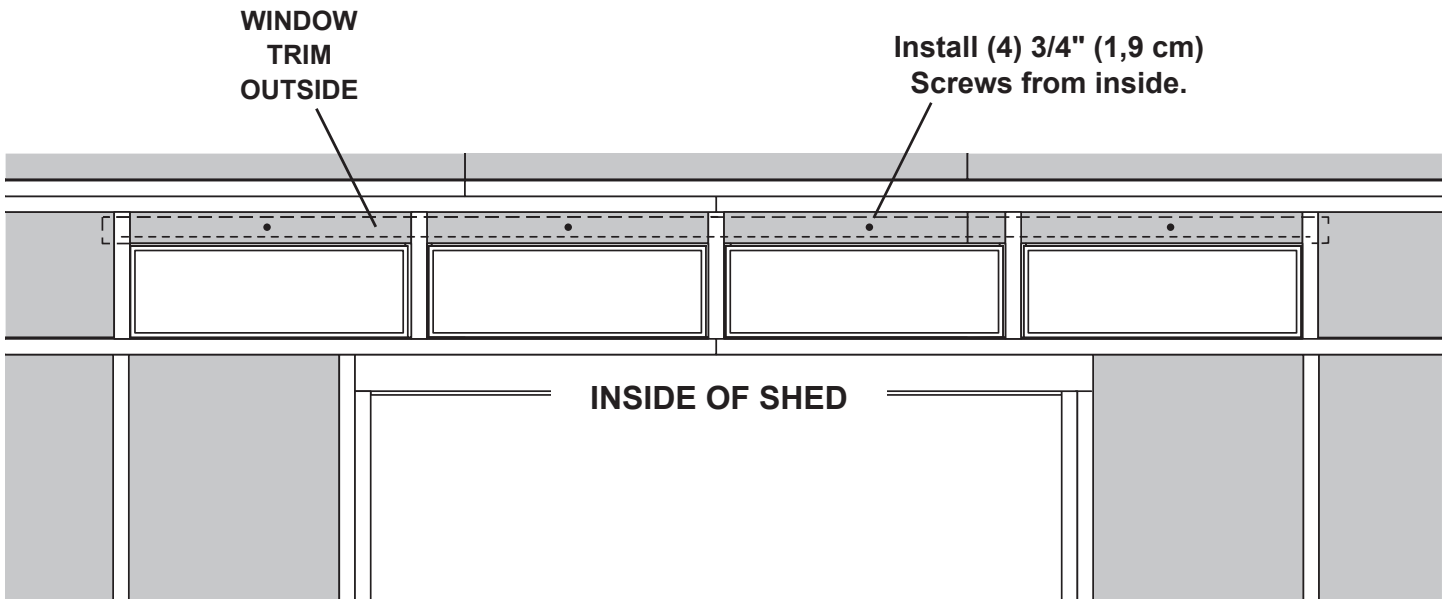

Your windows and window trim are now installed.

VENTS

PARTS REQUIRED:

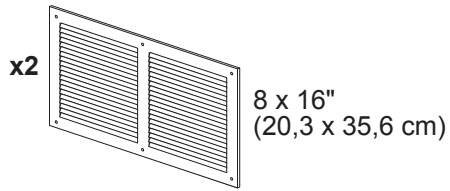

x12 
1/2" (1,3 cm)

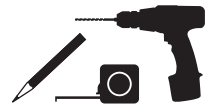

 **BEGIN**

1 Locate and mark for two vents in both side walls, as shown. Install (1) at top and (1) at bottom

Cut out marked openings.

Caulk behind vent flanges.

Secure vents with 1/2" screws.

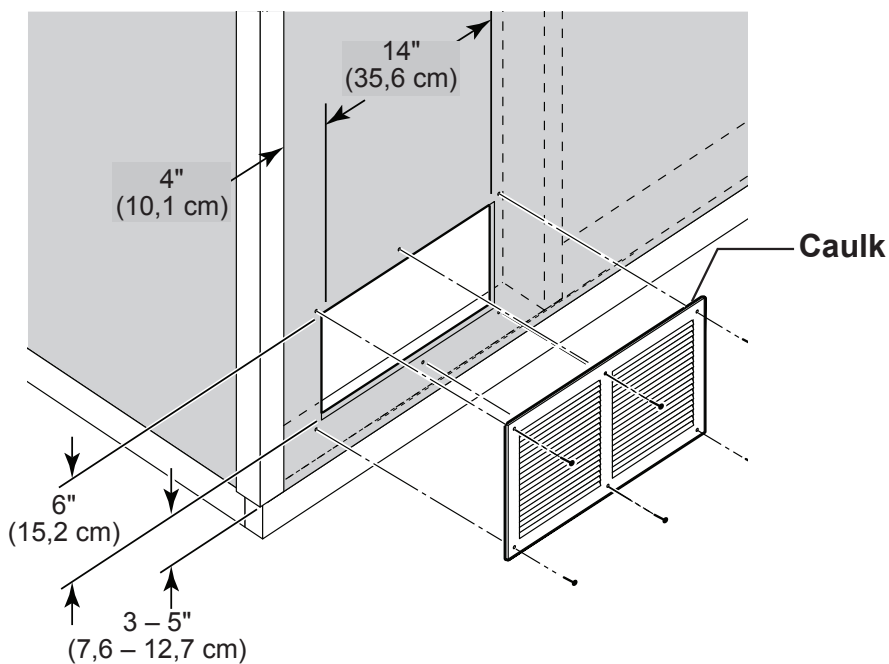
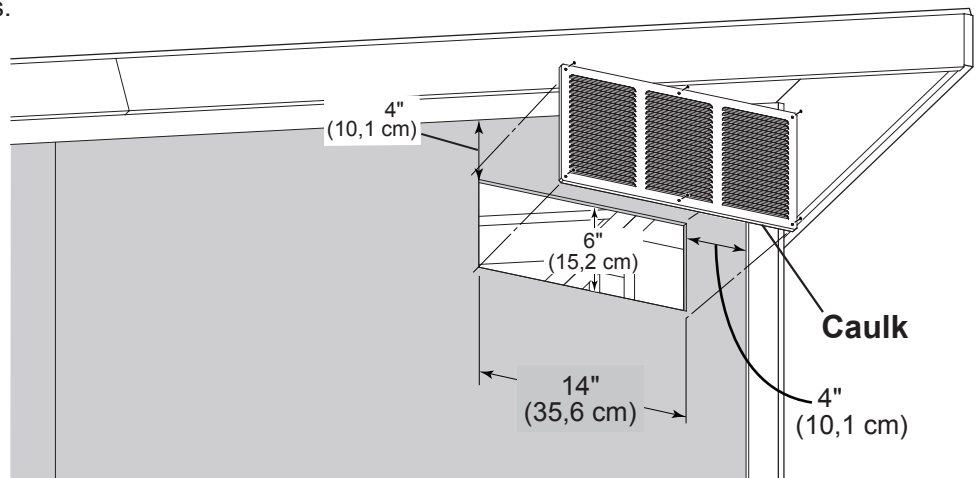

 **FINISH**

Your vents are now installed.

PAINT & CAULK - NOT INCLUDED -



- Use acrylic latex caulk that is paintable. Caulk at all horizontal and vertical seams, between the trim and walls, and all around the door trim.
- Use a high quality exterior acrylic latex paint. When painting your building, there are a few key areas that can be easily overlooked that must be painted:
 - Bottom edge of all siding and trim
 - Inside of doors and all 4 edges

Note:

Prime all un-primed exterior wood before painting.
(Follow directions provided by manufacturer.)

DRIP EDGE

PARTS REQUIRED:



NOTE: Install drip edge to back of shed before installing roofing felt.

You must install drip edge to validate warranty.

BEGIN

- 1** Install drip edge flush along back roof panels. Flush ends to trim. Secure with 1" roofing nails 6" apart. Only nail top of drip edge.

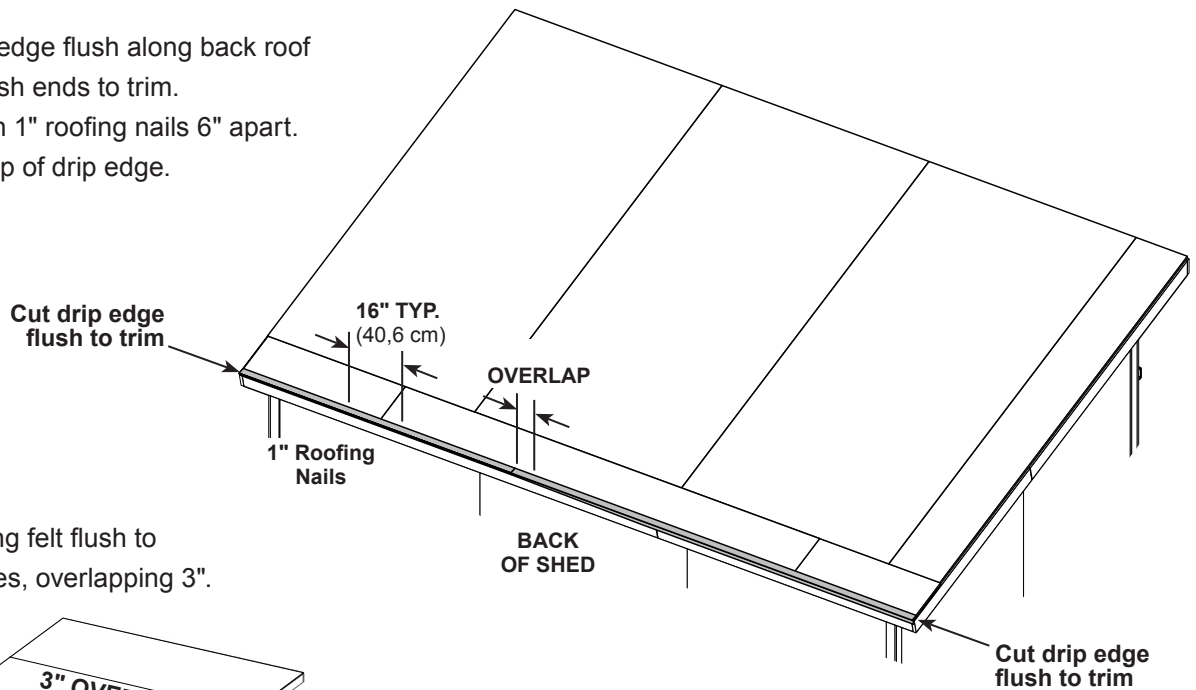

- 2** Install roofing felt flush to all roof edges, overlapping 3".

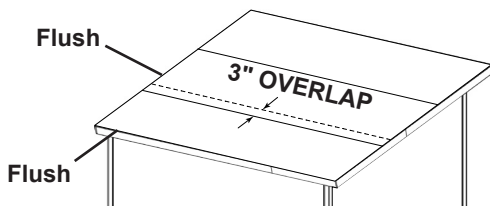

You must install roof felt to validate warranty.

DRIP EDGE

PARTS REQUIRED:



- 3** Install side drip edge flush along roof panels. Flush ends to trim (**Fig. A**).
Secure with 1" roofing nails 6" apart. Only nail top of drip edge.

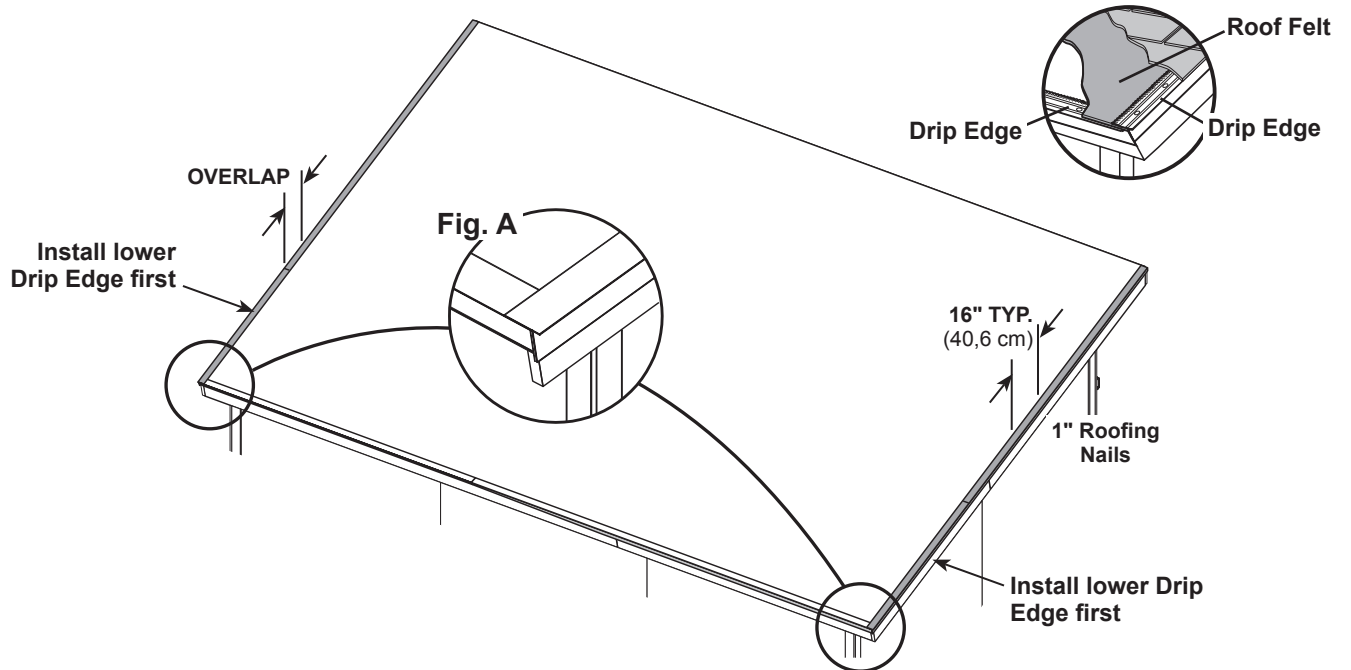

 **You must install drip edge to validate warranty.**



Your roof is now ready to shingle.

SHINGLES

- NOT INCLUDED -

• Follow directions provided by manufacturer and these instructions.

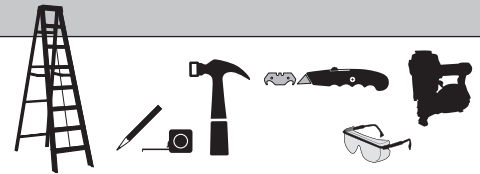

! Familiarize yourself with a 3-Tab Shingle.

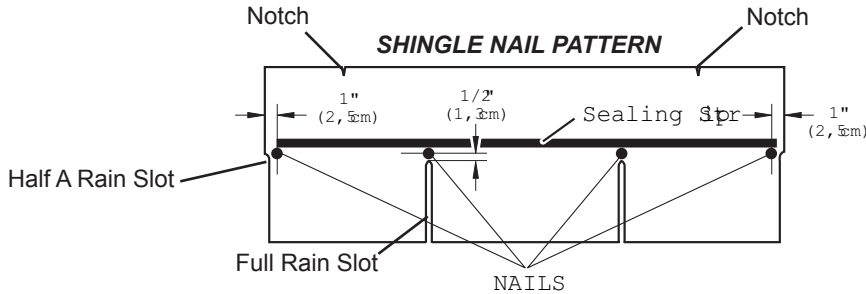

! NEVER DRIVE FASTENERS INTO OR ABOVE SEALING STRIPS.

✓ **BEGIN**
1

Install first starter row upside down, color up and flush to drip edge at bottom of roof panel. Use (4) nails per shingle. Starter row must be straight and level all the way across with lower edge of roof deck.

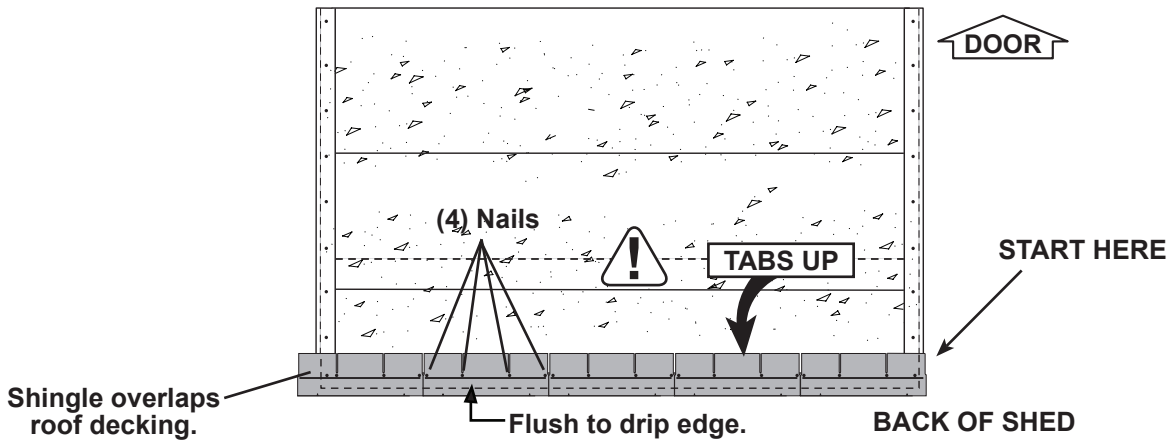

2 Begin where indicated on image below, install first row of shingles with notch flush with drip edge.

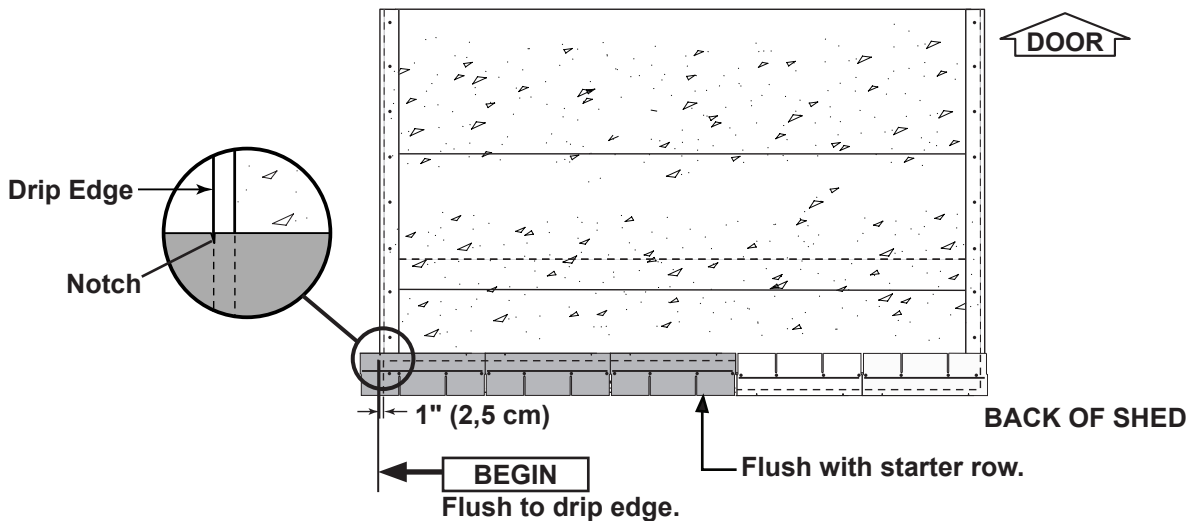

SHINGLES

continued...

- 3** Install second row of shingles flush at top of first row's rain slots. Ensure flush to drip edge at back side. Stagger each row.

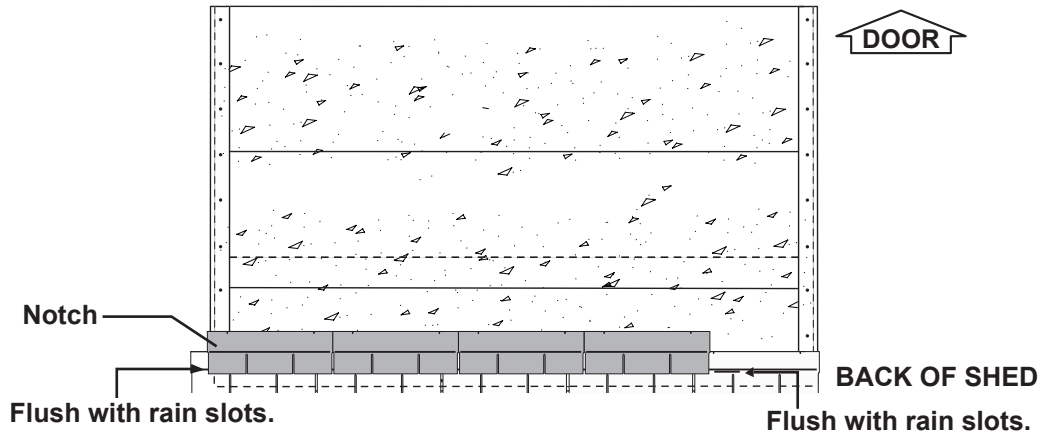

- 4** Continue installing rows of shingles by staggering at front.

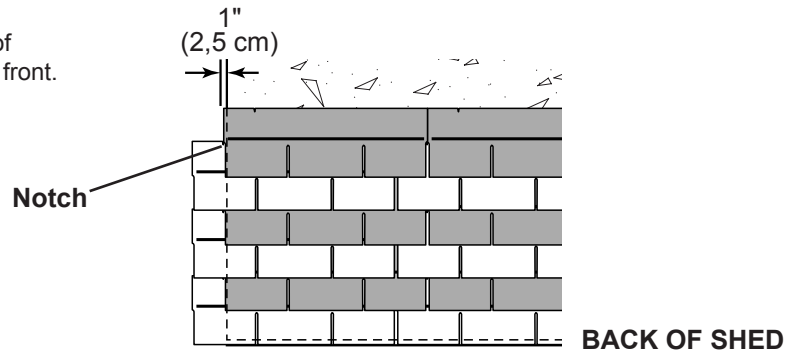

- 5** Continue installing rows of shingles to the front of the shed. At the front edge of the shed make sure there is a maximum of 5" or less to the rain slot, as shown below. If shingles overlap at front roof edge cut to roof edge with a utility knife.

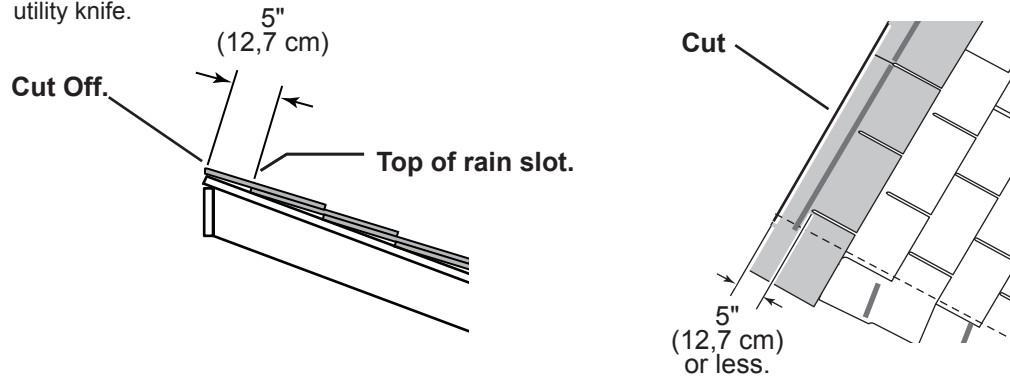

- !** • If more than 5" to rain slot you must install another row of shingles.

- 6** Using your shingle hooked blade carefully cut shingles along chalk line.

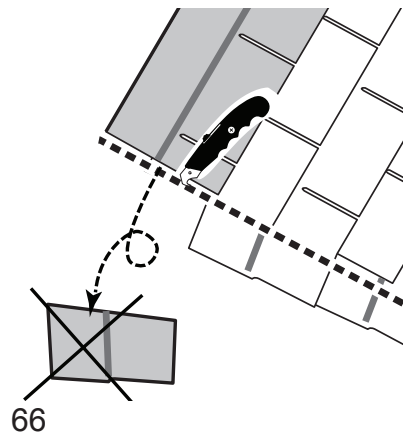

SHINGLES - DRIP EDGE

- 7 Install drip edge over top shingle row with 1" overhang over roof edge.

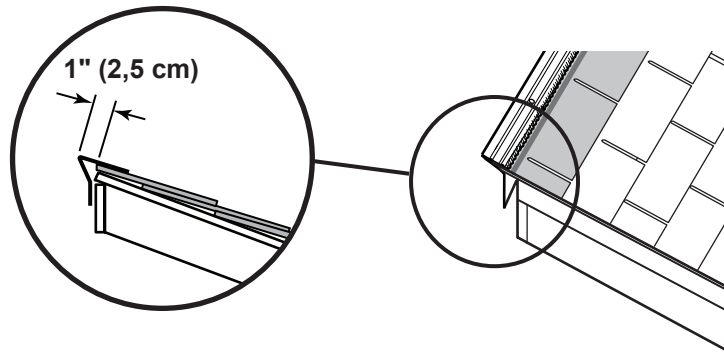

- 8 Using your shingle hooked blade carefully cut shingles on a flat surface along the rain slots, using a chalk line for reference.

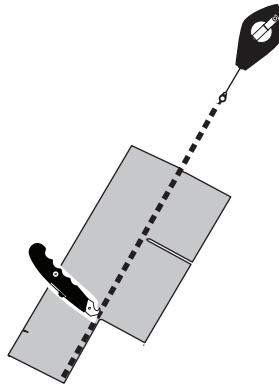

- 9 Align remaining shingles with edge of the front drip edge.

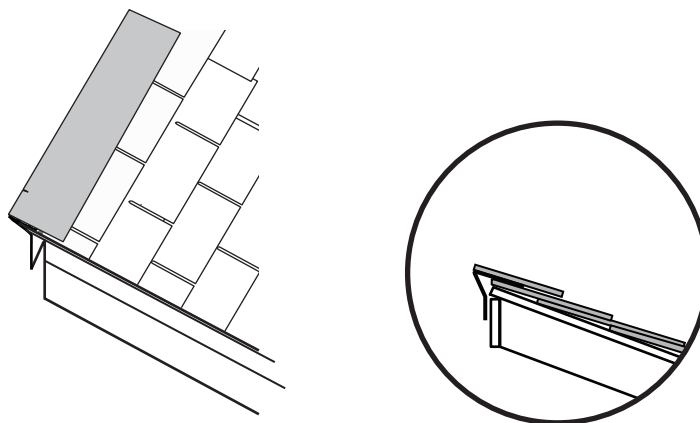

You have finished shingling your roof.

16252-A 12' x 8' Modern Order Form

CATEGORY	PART DESCRIPTION	PART SIZE	PART ITEM #	BUILDING QTY.	PART ID
2 X 3	Gable Fascia Backer	LUM SPF 2 X 3 X 72 #2&BTR	Q 7200000000	2	OY
	Gable Fascia Backer	2 X 3 X 31 15/16" O/E	Q 3115130000	2	RMA
	Front Eave Extensions	2 X 3 X 10-7/16" 12.5" L/S EAVE EXTENSION	Q 10071313000	11	QVA
	Back Wall Filler	LUM SPF 2X3X96 #2&BTR	12115	1	PT
	Back Wall Filler	2 X 3 X 59-1/4" BACK WALL FILL	Q 5904000000	1	GKA
2 X 4	Back Wall Studs	2 X 4 X 68" STUD	O 6800000000	7	UM
	Back Wall Top & Bottom Plates/Doublers "A"	LUM SPF 2X4X96 #2&BTR	12306	4	TP
	Back Wall Top & Bottom Plates	2X4X48" DOUBLER/ PLATE/ CRATE	O 4800000000	4	SP
	Side Wall Studs	2 X 4 X 78-1/16" 12.5" O/E STUD	O 78010000130	2	OFB
	Side Wall Studs	2 X 4 X 82-1/2" 12.5" O/E STUD	O 82080000130	2	NES
	Side Wall Studs	2 X 4 X 86-15/16" 12.5" O/E STUD	O 86150000130	2	KTB
	Doublers "B"	*LUM SPF 2X4X72 #2&BTR	O 7200000000	2	TM
	Front Wall Framing Bottom plate	2 X 4 X 40" PLATE	O 4000000000	2	SKA
	Front Wall Framing	2 X 4 X 86-1/8" CRATE LONG SIDE	O 8602000000	2	OHB
	Jack Stud	2 X 4 X 68-9/16" STUD	O 6809000000	2	NCE
	Header	2 X 4 X 67"	O 6700000000	2	AM
	King/Frontwall Stud	*2X4X72-1/2" #2&BTR	O 7208000000	4	PTA
	Front Wall Framing Top Plate	2 X 4 X 70 1/2"	O 7008000000	2	AYA
	Front Wall Framing Cripplers	2 X 4 X 12-1/8" CRIPPLER	O 1202000000	5	PPA
	Rafters	2 X 4 X 92 3/16" 12.5" 12.5" RAFT	O 92031313000	11	SDC
2 X 4 TREATED FLOOR FRAME	Bond Board "B"	LUM TRTD 2 X 4 X 48 #2&BTR	P 4800000000	2	---
	Floor Joist	LUM TRTD 2 X 4 X 87 #2&BT	P 8700000000	10	---
	Bond Board "A"	LUM TRTD 2 X 4 X 96 #2&BTR	P 9600000000	2	---
1 X 3 PINE	Side Rake Framing	LUM SPF 1X3 X72" SQ EDGE PET	U 7200000000	2	HJ
	Side Rake Framing	1 X 3 X 31-15/16" 12.5" O/E TRIM	U 3115130000	2	THB
	Gauge Block	1 X 3 X 5" PINE FILLER	U 0500000000	1	GAA
7/16 OSB	Upper Roof Panel "A"	OSB 7/16" x 4' x 8'	11110	3	---
	Upper Roof Panel "B"/Small Roof Panel "A"	7/16" OSB 11 7/8" X 96"	C 96001114000	1	---
	Small Roof Panel "B"	7/16" OSB 10-11/16" X 96" ROOF PANEL	C 96001011000	1	---
	Small Roof Panel "C"	7/16" OSB 10-11/16" X 31-7/8"	C 31141011000	1	---
	Small Roof Panel "D"	7/16" OSB 10 11/16" X 28" ROOF PANEL	C 28001011000	1	---
	Header Filler	7/16" OSB 3 1/4" X 66 3/4" HEADER	C 66120304000	2	---
5/8 OSB	Floor Panel "A"	OSB 5/8" X 4' X 8'	11117	1	---
	Floor Panel "B"	5/8" OSB 48" X 90" FLOOR PANE	E 90004800000	1	---
	Floor Panel "C"	5/8" OSB 42" X 96" FLOOR PANEL	E 96004200000	1	---
NO GROOVE SIDING	Frontwall Panel - Right	*NG SANTA CLARA RGT FRONTWALL	K 96004800301	1	---
	Frontwall Panel - Left	*NG SANTA CLARA LEFT FRONTWALL	K 96004800401	1	---
	Backwall Panels	SIDING NGSE 3/8X4X76"	11501	3	---
	Side Walls Short Panel- Right	NG SANTA CLARA RGT SIDEWALL	K 84004800130	1	---
	Side Walls Short Panel- Left	NG SANTA CLARA LFT SIDEWALL	K 84004800230	1	---
	Side Walls Long Panel-Right	NG SANTA CLARA RGT SIDEWALL	K 96004200130	1	---
	Side Walls Long Panel-Left	NG SANTA CLARA LFT SIDEWALL	K 96004200230	1	---
	Front Wall Filler "A"	3/8" NG 10-7/16" X 48" OVER DOOR PANEL	K 48001007000	1	---
	Front Wall Filler "B"	3/8" NG 4-1/2" X 48" WALL FILLER	K 48000408004	1	---
	Window Filler	3/8" NG 1 1/2" X 9"	K 09000108000	1	---
	Side Soffit Panels	3/8" NG 5 1/4" X 94-7/16" SOFFIT	K 94070504000	2	---
	Right Wall Filler	3/8" NG 2-11/16" X 12-1/4" WALL FILLER	K 12040211100	1	---
	Left Wall Filler	3/8" NG 2-11/16" X 12-1/4" WALL FILLER	K 12040211200	1	---
	Front Wall Soffit	3/8" NG 10 3/8" X 75-5/8" SOFFIT	K 7510100600S	1	---
	Front Wall Soffit	3/8" NG 10 3/8" X 79-5/8" SOF	K 7910100600S	1	---
	Right Back Corner Trim	3/8" NG 2" X 73 7/16" 12.5" O/E	K 73070200130	1	---
	Left Back Corner Trim	3/8" NG 2" X 73 7/16" 12.5" O/E	K 73070200230	1	---
	Corner Trim Back	3/8" NG 2" X 73-5/16" CORNER TRIM	K 73050200000	2	---
	Right Front Corner Trim	3/8" NG 2" X 93 1/8" 12.5" O/E	K 93020200130	1	---
	Left Front Corner Trim	3/8" NG 2" X 93 1/8" 12.5" O/E	K 93020200230	1	---
19/32 X 3 SMART TRIM	Horizontal Door Rail	19/32 TST 2 1/2" X 26 5/8"	UT26100208000	8	AH
	Upper Horizontal Trim	19/32 TST 2 1/2" X 72 3/4" TRIM	UT72120208000	2	ZD
	Horizontal Window Trim	19/32 x 2-1/2" x 58-3/4"	UT58120208000	4	TTB
	Front Corner Trim	19/32 TST 2 1/2" X 90-5/8"	UT90100208000	2	VAA
	Over Door Trim	19/32 TST 2" X 72" OVER DOOR TRIM	UT72000200000	1	OWB
	Transom Window Trim	19/32 TST 2 1/2" X 9"	UT09000208000	5	EY
19/32 X 4 SMART TRIM	Front Eave Trim	19/32 x 3-1/2" x 60-1/2"	UT60080308000	1	WAB
	Gable Trim - Right	19/32 TST 3 1/2" X 61 1/16" 12.5" O/E	UT61010308130	1	UDR
	Gable Trim - Left	19/32 TST 3 1/2" X 61 1/16" 12.5" O/E	UT61010308230	1	IDL
	Gable Trim	19/32 TST 3 1/2" X 45"	UT45000308000	2	WQA
	Front & Back Eave Trim	19/32 TST 3 1/2" X 96"	UT96000308000	2	ZX
	Back Eave Trim	19/32 TST 3 1/2" X 59-1/4" EAV	UT59040308000	1	HBA
19/32 X 6 SMART TRIM	Door Rail Gauge	19/32 TST 5 1/2" X 11 5/16"	UT11050508000	1	WDA
PURCHASED COMPONENTS	Door Stiffener	LSL 1-1/4 X 2-1/4 X 69 PET	12715	2	OO
	Threshold	THRESHOLD 7/8" X 1-1/2" X 63-7/8	15420	1	---
	Simpson Roof Clips	RAFTER TIE (SIMPSON H 2.5 A)	15706	11	---
	Exterior Vent- white	VENT 16" X 8" EXTERIOR (WHITE)	15002	2	---
	Transom window (single)	WINDOW 9 X 27 TRANSOM (SINGLE)	15235	4	---
	Black T&D Handle	HANDLE - T 5-1/2" SHAFT & "D"	15375	1	---
	Hardware Kit	H/K (SOHO 33149) 12x8 MODERN - LOWES	15602	1	---
	Spring Bolt	SPRING BOLT, 1.63 TRAVEL, W/SCREWS	15129	2	---
PACKAGING	Instructions		16252-A	1	---
Right Door Assembly	30228-R				
	Door Panel	*3/8" NG 31 3/8" X 71 1/2" DOOR PANEL FROM 76" NG	K 710831060SR	1	---
	Right Hinge Assembly	HINGE RIGHT (RED) 19/32x3 THIN TRIM	30121-TT	1	---
	Vertical Door Stiles	19/32 TST 2 1/2" X 71 5/8"	UT71100208000	1	GY
	Horizontal Door Rails	19/32 TST 2 1/2" X 26 5/8"	UT26100208000	2	AH
Left Door Assembly	30228-L				
	Door Panel	*3/8" NG 31 3/8" X 71 1/2" DOOR PANEL FROM 84" NG	K 710831060SL	1	---
	Left Hinge Assembly	HINGE LEFT (GREEN) 19/32x3 THIN TRIM	30131-TT	1	---
	Vertical Door Stiles	19/32 TST 2 1/2" X 71 5/8"	UT71100208000	1	GY
	Horizontal Door Rails	19/32 TST 2 1/2" X 26 5/8"	UT26100208000	2	AH

LIMITED CONDITIONAL WARRANTY*

Backyard Storage Solutions, LLC warrants the following:

1. Every product is warranted from defects in workmanship and manufacturing for 1 year.
2. All accessories, hardware and metal components are warranted for 2 years.
3. All Oriented Strand Board (OSB) is warranted for 2 years
4. Siding and Trim is warranted for 10 years.
5. Solar Shed windows are warranted for 1 year.
6. Cedar lumber is warranted for 15 years.
7. Preserved Pine is warranted for 10 years.
8. Redwood is warranted for 10 years.

Backyard Storage Solutions, LLC will repair, replace or pay for the affected part. In no event shall Backyard Storage Solutions, LLC pay the cost of labor or installation or any other costs related thereto. All warranties are from date of purchase. If a cash refund is paid on an affected part, it will be prorated from the date of purchase.

CONDITIONS

The warranty is effective only when:

1. The unit has been erected in accordance with the assembly instructions.
2. The unit has been properly shingled and painted or stained and reasonably and regularly maintained thereafter.
3. The failure occurs when the unit is owned by the original purchaser.
4. Backyard Storage Solutions, LLC has received the warranty registration card within thirty (30) days of purchase and notification of the failure in writing within the warranty period specified above.
5. Backyard Storage Solutions, LLC has had reasonable opportunity during the sixty (60) days following receipt of notification to inspect and verify the failure prior to commencement of any repair work.

REQUIREMENTS

Storage Buildings

To validate your warranty, it is necessary to properly maintain your Backyard Storage Solutions, LLC unit; shingle the roof and paint or solid-colored stain the siding using quality, 100% acrylic latex exterior product with a minimum of two (2) coats within thirty (30) days of assembly; caulk above all doors and all horizontal and vertical trim boards; paint and seal all exposed edges, sides and faces of siding/trim and OSB siding to include all exterior walls and all sides and all edges of doors.

Gazebos & Pergolas

To validate your warranty, it is necessary to properly maintain your Backyard Storage Solutions, LLC unit. This includes treating all of the exposed cedar and pine surfaces on your gazebo or pergola structure with an exterior grade wood preservative, an exterior oil-based semi-transparent stain, an acrylic latex exterior paint or an acrylic latex solid color exterior stain within 30 days of assembly and as needed thereafter to maintain your warranty.

Keep vegetation trimmed away from building and make sure siding panels and trim do not come in contact with masonry or cement. The minimum ground clearance for siding must be one half inch (½ inch) from concrete slab or two and one half inches (2 ½") from the ground when building is erected or constructed on a treated wood floor kit. Water from sprinklers must be kept off unit. In no event will Backyard Storage Solutions, LLC be responsible for any indirect, incidental, consequential or special damages nor for failure(s) that are caused by events, acts or omissions beyond our control including, but not limited to, misuse or improper assembly, improper maintenance (which eventually leads to rot or decay) and acts of God. Backyard Storage Solutions, LLC will not be held responsible for any labor costs incurred to construct your unit.

This warranty gives you certain specific rights that vary from state to state.

CLAIM PROCEDURE

To make a claim under this warranty, you can either call 1-888-827-9056 or email: customerservice@backyardproducts.com.

Please have ready the information below when you call or include the information in your email:

1. The model and size of the product.
2. A list of the part(s) for which the claim is made.
3. Proof of purchase of the Backyard Storage Solutions, LLC item, as shown on the original invoice or receipt.
4. Run code: found on exterior product label or assembly instructions enclosed in the product package.

All other inquiries can be mailed to:

Backyard Storage Solutions, LLC
Attn: Customer Service
1000 Ternes
Monroe, MI 48162

***WARRANTY TERMS MAY VARY OUTSIDE THE U.S.A.**

IMPORTANT: This is your warranty certificate.

10Y MV LDR: 3/20/2019